

# Trimble 5600 Series



 **Geodesical**

# Trimble 5600 Series

## User Guide

 Geodesical

## Corporate Office

Trimble Navigation Limited  
5475 Kellenburger Road  
Dayton, Ohio 45424-1099  
U.S.A.

800-538-7800 (Toll Free in U.S.A.)  
+1-937-233-8921 Phone  
+1-937-233-9441 Fax  
[www.trimble.com](http://www.trimble.com)

## Copyright and Trademarks

Copyright © 2001-2002, Trimble Navigation Limited. All rights reserved. Geodimeter, Tracklight and Trimble are trademarks of Trimble Navigation Limited, registered in the United States Patent and Trademark Office.

The Globe & Triangle logo and Autolock are trademarks of Trimble Navigation Limited.

All other trademarks are the property of their respective owners.

## Release Notice

This is the December 2002 release version 04.00 of the Trimble 5600-series User Guide, part number 571 702 011. It applies to the Trimble 5600-series total station.

The following limited warranties give you specific legal rights. You may have others, which vary from state/jurisdiction to state/jurisdiction.

### Hardware Limited Warranty

Trimble Navigation Limited warrants that this hardware product (the "Product") will perform substantially in accordance with published specifications and be substantially free of defects in material and workmanship for a period of one (1) year starting from the date of delivery. The warranty set forth in this paragraph shall not apply to software products.

### Software License, Limited Warranty

This Trimble software product, whether provided as a stand-alone computer software product, built into hardware circuitry as firmware, embedded in flash memory, or stored on magnetic or other media, (the "Software") is licensed and not sold, and its use is governed by the terms of the relevant End User License Agreement ("EULA") included with the Software. In the absence of a separate EULA included with the Software providing different limited warranty terms, exclusions and limitations, the following terms and conditions shall apply. Trimble warrants that this Trimble Software product will substantially conform to Trimble's applicable published specifications for the Software for a period of ninety (90) days, starting from the date of delivery.

### Warranty Remedies

Trimble's sole liability and your exclusive remedy under the warranties set forth above shall be, at Trimble's option, to repair or replace any

Product or Software that fails to conform to such warranty ("Nonconforming Product") or refund the purchase price paid by you for any such Nonconforming Product, upon your return of any Nonconforming Product to Trimble in accordance with Trimble's standard return material authorization procedures.

## Warranty Exclusions and Disclaimer

These warranties shall be applied only in the event and to the extent that the Products and Software are properly and correctly installed, configured, interfaced, maintained, stored, and operated in accordance with Trimble's relevant operator's manual and specifications, and; (ii) the Products and Software are not modified or misused. The preceding warranties shall not apply to, and Trimble shall not be responsible for defects or performance problems resulting from (i) the combination or utilization of the Product or Software with hardware or software products, information, data, systems, interfacing or devices not made, supplied or specified by Trimble; (ii) the operation of the Product or Software under any specification other than, or in addition to, Trimble's standard specifications for its products; (iii) the unauthorized modification or use of the Product or Software; (iv) damage caused by accident, lightning or other electrical discharge, fresh or salt water immersion or spray; or (v) normal wear and tear on consumable parts (e.g., batteries). Trimble does not warrant or guarantee the results obtained through the use of the Product.

THE WARRANTIES ABOVE STATE TRIMBLE'S ENTIRE LIABILITY, AND YOUR EXCLUSIVE REMEDIES, RELATING TO PERFORMANCE OF THE PRODUCTS AND SOFTWARE. EXCEPT AS OTHERWISE EXPRESSLY PROVIDED HEREIN, THE PRODUCTS, SOFTWARE, AND ACCOMPANYING DOCUMENTATION AND MATERIALS ARE PROVIDED "AS-IS" AND WITHOUT EXPRESS OR IMPLIED WARRANTY OF ANY KIND BY EITHER TRIMBLE NAVIGATION LIMITED OR ANYONE WHO HAS BEEN INVOLVED IN ITS CREATION, PRODUCTION, INSTALLATION, OR DISTRIBUTION INCLUDING, BUT NOT LIMITED TO, THE IMPLIED WARRANTIES OF MERCHANTABILITY AND FITNESS FOR A PARTICULAR PURPOSE, TITLE, AND NONINFRINGEMENT. THE STATED EXPRESS WARRANTIES ARE IN LIEU OF ALL OBLIGATIONS OR LIABILITIES ON THE PART OF TRIMBLE ARISING OUT OF, OR IN CONNECTION WITH, ANY PRODUCTS OR SOFTWARE. SOME STATES AND JURISDICTIONS DO NOT ALLOW LIMITATIONS ON DURATION OR THE EXCLUSION OF AN IMPLIED WARRANTY, SO THE ABOVE LIMITATION MAY NOT APPLY TO YOU.

TRIMBLE NAVIGATION LIMITED IS NOT RESPONSIBLE FOR THE OPERATION OR FAILURE OF OPERATION OF GPS SATELLITES OR THE AVAILABILITY OF GPS SATELLITE SIGNALS.

### Limitation of Liability

TRIMBLE'S ENTIRE LIABILITY UNDER ANY PROVISION HEREIN SHALL BE LIMITED TO THE AMOUNT PAID BY YOU FOR THE PRODUCT OR SOFTWARE LICENSE. TO THE MAXIMUM EXTENT PERMITTED BY APPLICABLE LAW, IN NO EVENT SHALL TRIMBLE OR ITS SUPPLIERS BE LIABLE FOR ANY INDIRECT, SPECIAL, INCIDENTAL OR CONSEQUENTIAL DAMAGES WHATSOEVER UNDER ANY CIRCUMSTANCE OR LEGAL THEORY RELATING IN ANY WAY TO THE PRODUCTS, SOFTWARE AND ACCOMPANYING DOCUMENTATION AND MATERIALS, (INCLUDING, WITHOUT LIMITATION, DAMAGES FOR LOSS OF BUSINESS PROFITS, BUSINESS INTERRUPTION, LOSS OF BUSINESS INFORMATION, OR ANY OTHER PECUNIARY LOSS), REGARDLESS WHETHER TRIMBLE HAS BEEN ADVISED OF THE POSSIBILITY OF ANY SUCH LOSS AND REGARDLESS OF THE COURSE OF DEALING WHICH DEVELOPS OR HAS DEVELOPED BETWEEN YOU AND TRIMBLE. BECAUSE SOME STATES AND JURISDICTIONS DO NOT ALLOW THE EXCLUSION OR LIMITATION OF LIABILITY FOR CONSEQUENTIAL OR INCIDENTAL DAMAGES, THE ABOVE LIMITATION MAY NOT APPLY TO YOU.

NOTWITHSTANDING THE ABOVE, IF YOU PURCHASED THIS PRODUCT OR SOFTWARE IN THE EUROPEAN UNION, THE ABOVE WARRANTY PROVISIONS MAY NOT APPLY. PLEASE CONTACT YOUR DEALER FOR APPLICABLE WARRANTY INFORMATION.

### Notices

Class B Statement – Notice to Users. This equipment has been tested and found to comply with the limits for a Class B digital device, pursuant to Part 15 of the FCC rules. These limits are designed to provide reasonable protection against harmful interference in a residential installation. This equipment generates, uses, and can radiate radio frequency energy and, if not installed and used in accordance with the instructions, may cause harmful interference to radio communication. However, there is no guarantee that interference will not occur in a particular installation. If this equipment does cause harmful interference to radio or television reception, which can be determined by turning the equipment off and on, the user is encouraged to try to correct the interference by one or more of the following measures:

- Reorient or relocate the receiving antenna.

- Increase the separation between the equipment and the receiver.
- Connect the equipment into an outlet on a circuit different from that to which the receiver is connected.
- Consult the dealer or an experienced radio/TV technician for help.

Changes and modifications not expressly approved by the manufacturer or registrant of this equipment can void your authority to operate this equipment under Federal Communications Commission rules.

**THIS DEVICE COMPLIES WITH PART 15  
OF THE FCC RULES**

**OPERATION IS SUBJECT TO THE FOLLOWING  
TWO CONDITIONS:**

**(1) THIS DEVICE MAY NOT CAUSE HARMFUL  
INTERFERENCE. AND**

**(2) THIS DEVICE MUST ACCEPT ANY  
INTERFERENCE RECEIVED, INCLUDING  
INTERFERENCE THAT MAY CAUSE  
UNDESIRE OPERATION**

Using Georadio:

Radio equipment used complies with the Essential requirements of the R&TTE Directive 1999/5/EC

**CE 0413**



This equipment complies with the regulation of C-Tick

**N 324**

 **Geodesical**

# Laser Safety Information

Before using the instrument, make sure that you understand this User Guide, as well as all equipment and jobsite safety requirements.

## Laser Safety

This equipment has been tested and found to comply with IEC 60825-1 January 2001, 21 CFR 1040.10 and 1040.11 except for deviations pursuant to Laser Notice no. 50, dated May 27, 2001.



---

Use of controls or adjustments or performance of procedures other than those specified herein may result in hazardous LED or Laser radiation exposure. As with any bright light source, such as the sun, electric welding arcs or arc lamps, common sense applies. DO NOT look into the laser aperture when the laser is on. For further information regarding safe use of lasers, refer to the IEC standard 60825-1 January 2001.

---

## Queries

Address any questions you may have about laser safety to:  
Trimble  
5475 Kellenburger Road  
Dayton, OH U.S.A. 45424-1099  
Attention: Laser Safety Officer, Quality Assurance Group  
Phone (937) 233-8921 ext 824 or (800) 538-7800  
Fax (937) 233-9661

## Trimble 5600 & ATS

The **Trimble 5600 & ATS** contains one light source:

A LED for the distance measuring function operating at 850 nm (infrared, non-visible light), with a beam divergence of 1.6 mrad and an output power of < 0.44 mW, laser CLASS 1.



## Trimble 5600 DR Standard

The **Trimble 5600 DR Standard** contains one light source:

A laser diode for both distance measuring and laser pointer function operating at 660 nm (visible light), with a beam divergence of 0.4 x 0.8 mrad and an output power of < 1 mW, laser CLASS 2.

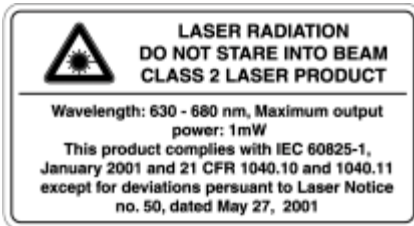



## Trimble 5600 DR 200+ & DR 300+ (and optional Laser Pointer)

The **Trimble 5600 DR 200+ & DR 300+ (with Laser Pointer)** may contain two light sources:

A laser diode for the distance measuring function operating at 850 nm (infrared, non-visible light), with a beam divergence of  $0.4 \times 0.8$  mrad and an output power of  $< 0.48$  mW, laser CLASS 1.



As an option, a **Laser Pointer** operating at 635 – 670 nm (visible light), with a beam divergence of 0.3 mrad and an output power of  $< 1$  mW, laser CLASS 2.

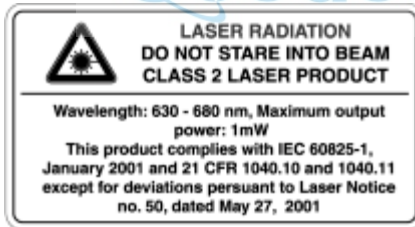



## Welcome to Trimble 5600 Series

Comments about this manual .....	B
Glossary of terms used with the System .....	B

## 1 Introduction

Unpacking & Inspection .....	1-3
Inspection.....	1-3
Aiming at the target.....	1-3
Controls .....	1-4
Pre-Measurement.....	1-6
Connecting the external battery to the instrument .....	1-6
The Side Cover.....	1-7
The Central Unit.....	1-8
Additional Control Units.....	1-9
Laser and LED Information.....	1-10
Trimble 5600-series & ATS .....	1-10
Trimble 5600 DR Standard -series.....	1-11
Trimble 5600 DR 200+ & DR 300+ -series.....	1-13

## 2 Surveying methods

In general.....	2-2
Conventional surveying with servo .....	2-2
Autolock.....	2-3
Robotic Surveying .....	2-3
Conventional surveying with Autolock .....	2-4
Important information when measuring with high accuracy (and using the instrument's Tracker).....	2-4
Aiming .....	2-5
Robotic Surveying.....	2-6

Important information when measuring with high accuracy  
(and using the instrument's Tracker)..... 2-6  
Equipment ..... 2-7  
Radio communication ..... 2-7

### **3 Angle Measurement System**

Overview..... 3-3  
The Angle Measuring Technique ..... 3-3  
    Dual Axis Compensator ..... 3-3  
    Correction for Collimation Errors..... 3-4  
    Correction for Trunnion Axis Tilt..... 3-4  
    Single-Face Angle Measurement..... 3-5  
Two-Face Angle Measurement..... 3-5

### **4 Distance Measurement System**

Overview..... 4-3  
Distance Measurement..... 4-3  
    Automatic control of signal level..... 4-4  
    Measurement range and accuracy..... 4-4

### **5 Servo**

Overview..... 5-2  
Servo controls..... 5-2  
    Motion knobs ..... 5-2

### **6 Tracklight**

Overview..... 6-3  
    Changing the bulb ..... 6-4

## 7 Tracker

Overview.....	7-2
---------------	-----

## 8 Beam adjustment

Laser beam DR Standard .....	8-2
Overview .....	8-2
Alignment .....	8-2
Adjustment.....	8-4
Laser Pointer DR 200+ & DR 300+ .....	8-6
Overview.....	8-6
Alignment .....	8-6
Adjustment.....	8-7

## 9 Radio

Overview.....	9-3
Radio controls.....	9-3
Select radio channel .....	9-3
Station address .....	9-3
Radio license.....	9-4
Range .....	9-4

## 10 Power Supply

Batteries.....	10-2
Internal Battery unit (Central unit) .....	10-2
External Battery/Radio Battery .....	10-2
Single Adapter .....	10-3
Multi Adapter.....	10-3
Battery Cables.....	10-4
Battery Charging.....	10-5
Single Charger (571 906 214).....	10-5
Super Charger (571 906 145).....	10-5

Power Unit (571 906 146)..... 10-6  
About charging NiMH (and NiCd) batteries..... 10-6  
Bat Low..... 10-6

## **11 Care & Maintenance**

Overview..... 11-2  
    Cleaning ..... 11-3  
    Condensation..... 11-3  
    Packing for Transport..... 11-3

## **12 Card Memory**

Overview..... 12-2  
Installation..... 12-2  
    How to connect to a Trimble 5600 Series instrument. 12-2  
    How to insert the memory card..... 12-5  
Memory Card ..... 12-8  
    Capacity ..... 12-8  
    Memory structure..... 12-8  
    Handling hints ..... 12-9

## **13 RMT Remote Targets**

In General..... 13-2  
RMT 602..... 13-3  
RMT 606..... 13-4  
RMT 600 TS ..... 13-5  
RMT Super Multi Channel ..... 13-7  
RMT SLR..... 13-8

## **14 Machine Control & Guidance**

Start up procedures..... 14-2

Georadio and Machine Control.....	14-3
Setting of radio channel and addresses .....	14-3
Remote operation and station establishment.....	14-3
Auto search .....	14-4
Distance meter calibration .....	14-5
RMT ATS Multi Channel .....	14-6







---

# Welcome to Trimble 5600 Series

Trimble AB, has since the release of Geodimeter<sup>®</sup> System 400 presented a large number of inventions within the surveying field; the tracklight<sup>®</sup>, the alpha-numeric keyboard, servo, one-person total station etc.

In 1994 we introduced the first flexible total station, Geodimeter System 600, which made it possible for the user to physically tailor his or her total station to his/her needs. In 1998 Geodimeter System 600 Pro was introduced which included a number of technical improvements such as a faster CPU and faster and smoother servo positioning.

The first introduction in 2000 was the Geodimeter 600 ATS. An instrument that can also be used for machine control.

To improve productivity of the Geodimeter System 600 even further, a new Direct Reflex and servo driven model, DR200+, was launched the same year.

The Trimble 5600 series was introduced in 2001 and in 2002 came the introduction of DR Standard and DR300+.

The system includes, of course, all the features that are typical for Geodimeter, such as servo-assisted drive (optional), numeric or alpha-numeric control units (keyboards), tracklight, tracker (optional), radio side cover (optional) and RS-232C communication.

---

## Comments about this manual

If you or your colleagues have any comments on this manual, we would be grateful to hear from you. Please write to:

### Trimble AB

Technical information dept.  
Box 64  
SE-182 11 DANDERYD  
Sweden

Or send an e-mail to: [info@trimble.se](mailto:info@trimble.se)

## Glossary of terms used with the System (Only with GDM CU)

- Area File:** A file in the memory device that holds known coordinates (Pno, N, E etc.) or Roadline data.
- A/M-key:** Aim/Measure button. Initiates a measurement and controls search and remote measurements.
- D:** Accurate measurement with mean value calc.
- dH & dV:** These values represents the collimation errors. When performing D-bar measurements in two faces these errors do not affect the accuracy of the measurement (HA, VA). If the values differs a lot from 0 it is recommended that you perform a test measurement (MNU5).

---

<b>Free Station:</b>	Also known as Resection. Location of the total station by measuring distance and/or angles to 2 or up to 8 points.
<b>FSTD:</b>	Fast Standard measurement, with A/M.
<b>IH:</b>	Instrument height over the point.
<b>Job File:</b>	A file in a the memory device that holds data collected in the field. This file can consist of any data.
<b>Logon:</b>	Entering Job file and memory unit when designing a U.D.S with program 40.
<b>Offset:</b>	Length offset to measured slope distance.
<b>Prism const:</b>	The prism's length offset from the 0-constant.
<b>Ref. Obj:</b>	Reference Object, also back sight.
<b>REG-key:</b>	The register key. This stores data in the data collector.
<b>RMT:</b>	Remote Measuring Target. The special prism used when performing robotics surveying (or remote surveying with auto lock), i.e.carrying out one-person measurements.
<b>R.O.E:</b>	Remote Object Elevation.
<b>RPU:</b>	Remote Positioning Unit. The rod half of the system when performing remote or robotic surveying.
<b>SH:</b>	Signal height.
<b>STD:</b>	Standard measurement, with A/M.

---

**TRK:** Tracking measurement, automatic and continuous measurement.

**U.D.S.:** User Defined Sequence. A program designed by the user determining what is collected, its order of collection and how it is displayed on the screen.

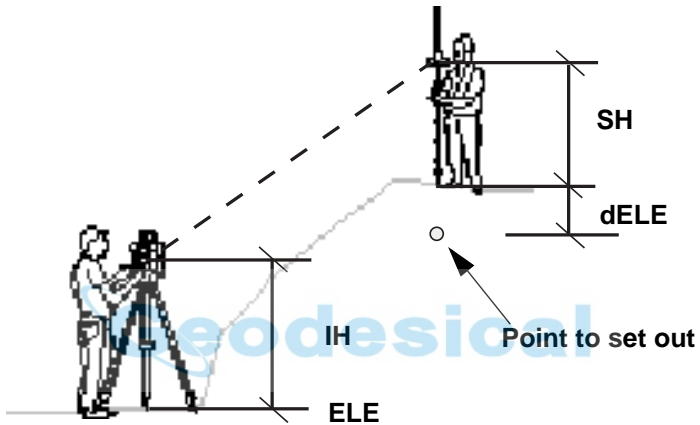

## Introduction

Unpacking & Inspection .....	1-3
Inspection.....	1-3
Controls.....	1-4
The Side Cover .....	1-7
The Central Unit.....	1-8
Additional Control Units.....	1-9
Additional Control Units .....	1-9
Laser and LED Information .....	1-10
Trimble 5600-series & ATS .....	1-10
Trimble 5600 DR Standard -series.....	1-11
Trimble 5600 DR 200+ & DR 300+ -series .....	1-13

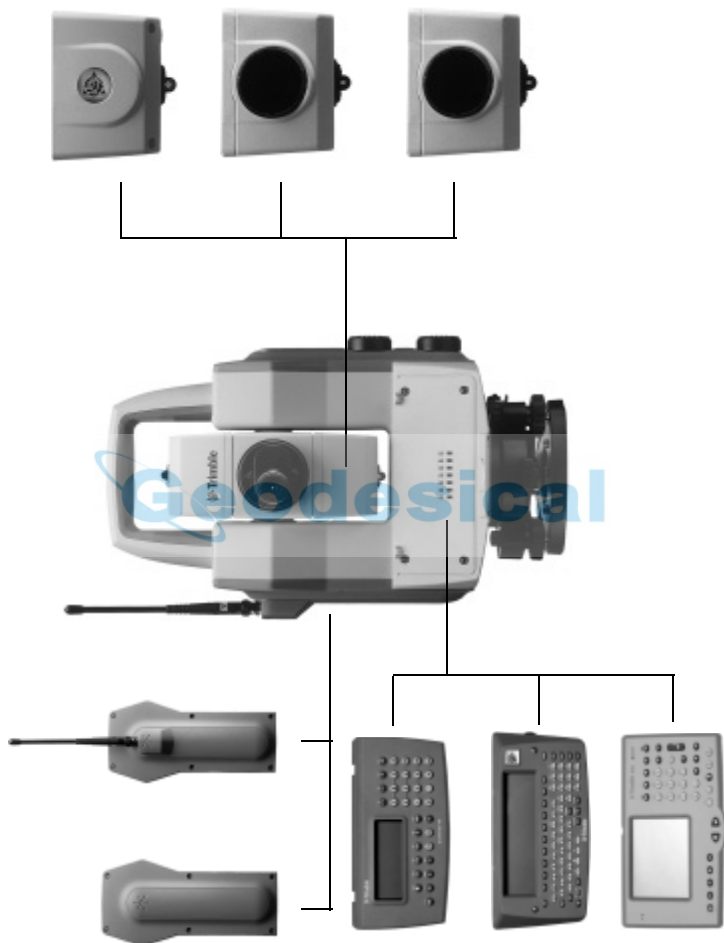

Figure 1.1 Trimble 5600 Series

## Unpacking & Inspection

Before we begin to describe the operating procedure of your Trimble instrument, it is first necessary to acquaint yourself with the equipment received:

- Instrument Unit
- Transport case
- Tribrach
- Rain cover
- Reflective sight marks (stick-on)
- User Manual
- Tool kit

*Note – Some equipment is market dependent*

### Inspection

Inspect the shipping container. If it is received in poor condition, examine the equipment for visible damage. If damage is found, immediately notify the carrier and the Trimble sales representative. Keep the container and packing material for the carrier's inspection.

## Controls

Here you find a list of the controls of your instrument. Please take a moment to familiarize your self with the names and the locations of the controls.



Figure 1.2 Trimble 5600 Series shown from the operator side (back), a central unit, a central battery unit and a radio side cover.





Figure 1.3 Trimble 5600 Series seen from the side, equipped with a central tracker unit and a radio side cover.

## Pre-Measurement

### Connecting the external battery to the instrument

The instrument can be equipped with an external battery that is connected to the instrument via the battery cable. The cable is to be connected to the connector on the instrument resp. battery as shown in the picture below.



Figure 1.4 Connecting the external battery to the instrument.

## The Side Cover

The instrument can be configured with two different side covers; a plain or a radio unit cover. It is possible to change side cover if you need another type, but it has to be done at a Trimble authorized service center.

### Plain Cover



### Radio Unit Cover



The radio unit cover is needed when you wish to use the instrument for remote surveying or robotic surveying (one-person total station), see chapter 1.5.

## The Central Unit

The central unit can be configured with the internal battery, the tracklight or the tracker unit. You can change between battery unit and tracklight by yourself, but the tracker unit must be installed at a Trimble authorized service center.



### **Internal battery**

The internal battery gives you 2 hours of continuous use.



### **Tracklight**

Tracklight is a visible guide light which is an aid to the rodman e.g. when setting out.



### **Tracker (only for servo instruments)**

The tracker has control of the instruments when using the system for robotic surveying (one-person system) or in Autolock™ mode.

## **Additional Control Units**

With Trimble 5600 Series you can work with two control units attached at the same time: one at the back of the instrument that serves as a master control unit and one at the front that serves as a slave unit.

Having two control units attached at the same time can be useful having in mind that they also contain internal memories.

The control unit at the front can also be very useful when measuring in two faces when you want to keep control of the point to measure in face 2.



## Laser and LED Information

### Trimble 5600-series & ATS

The Trimble 5600 Series & ATS instruments have been tested and complies with the regulations for a Class 1 LED product. See the laser safety information on the first pages of this manual. This means that no special precautions are required for safe operation as long as the instrument is not opened and the diode uncovered. In the figure below the LED aperture is pointed out.



Figure 1.5 LED aperture

## Trimble 5600 DR Standard -series

The Trimble 5600 DR Standard Series instrument has been tested and complies with the regulations for a Class 2 Laser product. See laser safety information on the first pages of this manual.



Figure 1.6 Laser apertures

The laser warning label is located on the side of the distance measuring unit as shown below



Figure 1.7 Laser warning label location

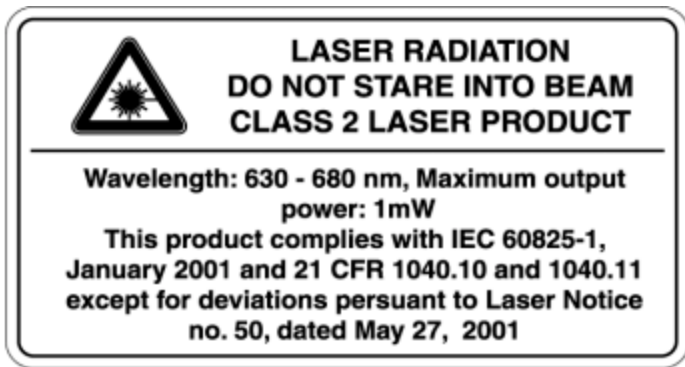

Figure 1.8 Laser warning label



## Trimble 5600 DR 200+ & DR 300+ -series

The Trimble 5600 DR 200+ & DR 300+ Series instrument has been tested and complies with the regulations for a Class 1 Laser product. The Trimble 5600 DR 200+ & DR 300+ Series instrument with an optional Laser Pointer has been tested and complies with the regulations for a class 2 Laser product. See laser safety information on the first pages of this manual.



Figure 1.9 Laser apertures

The laser warning label is located on the side of the distance measuring unit as shown below



Figure 1.10 Laser warning label location

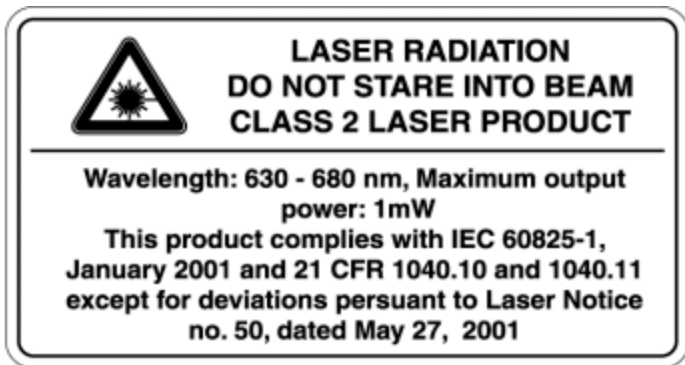

Figure 1.11 Laser warning label

## Surveying methods

In general .....	2-2
Conventional surveying with servo .....	2-2
Autolock .....	2-3
Robotic Surveying.....	2-3
Conventional surveying with Autolock.....	2-4
Important information when measuring with high accuracy (and using the instrument's Tracker).....	2-4
Aiming .....	2-5
Robotic Surveying .....	2-6
Important information when measuring with high accuracy (and using the instrument's Tracker).....	2-6

### In general

This chapter will describe the different ways of working with Trimble 5600 Series. First of all you can work conventionally with the system. Since the instrument is equipped with servo drive, you'll find that the system is very easy to handle, when setting out you can with a touch of a single key aim the instrument towards the set out point.

### Aiming at the target

To get the correct measurement with the instrument it is important that you aim at the sight marks of the target and towards the center of the range pole.

### Conventional surveying with servo

Your instrument is equipped with servo drive, this means a lot of advantages:

- In e.g. setting out you only need to give the point number. The instrument will calculate and aim automatically towards the precalculated bearing with a single press of the positioning key .
- For angle measurements, just aim towards the different reflector stations once. The instrument remembers and repeats the aiming process how ever many times and in what ever order you want.
- During manual aiming, the servo assists the horizontal and vertical adjustments. All that's needed is a light circular movement of the adjustment screw with your finger tip.
- Thanks to servo-drive, adjustments screws have no end positions. That means no unnecessary interruptions, when aiming.

## Autolock

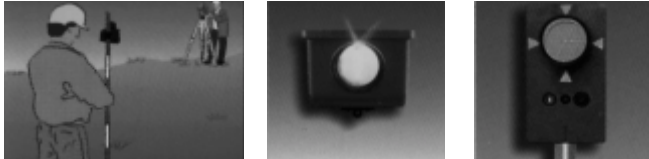

Secondly you can equip your instrument with a tracker unit and take full advantage of the feature we call Autolock™, this enables the instrument to lock on to a RMT and automatically follow it as it moves. This means that there is no need for fine adjustment or focusing.

## Robotic Surveying



With both a tracker unit and a telemetric link you can work with robotic surveying. This means that you can take over the control of the whole measurement from the point, i.e. you have a one-person system. On the following pages we will describe the different measuring techniques with The System.

## Conventional surveying with Autolock

With the feature Autolock, you do no longer have to fine adjust or focus, since this is taken care of by the system.

- To upgrade a base unit to Autolock, you'll only need to add a Tracker unit and an RMT target. It is also possible to measure in a conventional way without Autolock using an ordinary reflector.
- When setting out, you'll only need to supply a prestored point and the system will calculate the necessary data for setting out. Then, position the instrument with the positioning key. When the rodman, guided by the built-in Tracklight enters the Tracker's field of view (2.5m/100m), the instrument locks onto the RMT automatically. You're now able to fully concentrate on the information in the display (radial/right angle offset) and direct the rodman to the setting out point.

### Important information when measuring with high accuracy (and using the instrument's Tracker)

To achieve the highest accuracy when measuring distances shorter than 200 meters and using the Tracker unit you need to be aware of the following:

Always use the Miniature Prism (Part no. 571 126 060 or 571 204 312) mounted on your RMT. If you use a large reflector like the Super Prism (Part no. 571 125 021), reflections from the Tracker unit may have influence on the measured distance. The error can vary from 0 to 3 mm. This error doesn't occur using the Miniature Prism.

## Aiming

The adjustment between the two optical axes, i.e. the Telescope and the Tracker, may differ. The difference will make it seem like the instrument does not point towards the centre of the prism, when using Autolock (see fig. Below). This is not a problem since the two axis have their own collimation data. It is however important to make collimation test for both axes

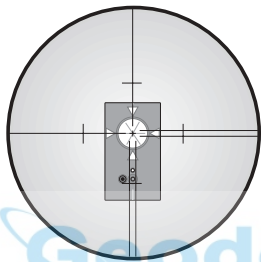

Without Autolock  
Manual aiming

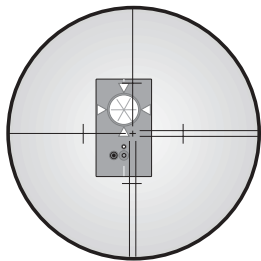

With Autolock

## How to check

You can check how good the instrument is calibrated yourself, by measuring towards the same prism with and without Autolock and compare the displayed angles:

*Without Autolock:*The instrument shows the angles for the tube.

*With Autolock:* The instrument shows the angles for the tracker

If the angle deviations are large you should calibrate both the tube and the tracker.

## Robotic Surveying

By equipping the instrument with a tracker unit, even aiming can be done from the measuring point. The entire measurement is performed from the point, with the same access to all functions of the total station as if you were standing beside it.

Robotic surveying means higher production capacity.

During setting-out, it's best with two people: one to handle the measuring with the RPU, and one to mark the points. Of course, the entire job can be performed by a single person.

The unique search function makes robotic surveying extremely efficient 24 hours a day.

### **Important information when measuring with high accuracy (and using the instrument's Tracker)**

To achieve the highest accuracy when measuring distances shorter than 200 meters using the tracker unit you need to be aware of the following:

If you use a large reflector like the Super Prism (Part no. 571 125 021) on your RMT, reflections from the Tracker unit may have influence on the measured distance. The error can vary from 0 to 3 mm. If you use the Miniature



Prism (Part no. 571 126 060) instead this error doesn't occur.

## **Equipment**

To be able to work with robotic surveying you'll only need one control unit, which you after station establishment etc. disconnect from the instrument and bring to the point. You will also need to equip your instrument with a radio side cover (see Chapter 1), a tracker unit, an RMT (Remote Target) and an external radio connected to the keyboard unit. The keyboard unit, the RMT and the external radio will hereafter be called, RPU.

## **Radio communication**

In order for the instrument and the RPU to be able to communicate you will have to set the same radio channel at the instrument and at the RPU. Select a channel with regards to other radio systems that might be in operation in your immediate area. If radio disturbances occur, e.g. if Info 103 is displayed, try another channel.



## Angle Measurement System

Overview .....	3-3
The Angle Measuring Technique.....	3-3
Dual Axis Compensator .....	3-3
Correction for Collimation Errors.....	3-4
Correction for Trunnion Axis Tilt.....	3-4
Single-Face Angle Measurement.....	3-5
Single-Face Angle Measurement.....	3-5
Two-Face Angle Measurement .....	3-5

### 3 Angle Measurement System

---



Figure 3.1 The Angle Measurement System

## Overview

The Trimble 5600 Series meets all demands for efficient and accurate angle measurement. It also allows you to choose the measuring method with which you feel most comfortable. The angle measurement system gives you full compensation for the following:

- Automatic correction for angle sensor errors.
- Automatic correction for collimation error and trunnion Axis tilt.
- Automatic correction for tracker collimation error.
- Arithmetic averaging for elimination of pointing errors.

## The Angle Measuring Technique

One of the strong features of the design of Trimble 5600 Series is its electronic angle measurement system, which eliminates the angle errors that normally occur in conventional theodolites. The principle of measurement is based on reading an integrated signal over the whole surface of the angle sensor and producing a mean angular value. In this way, inaccuracies due to eccentricity and graduation are eliminated.

## Dual Axis Compensator

The instrument is also equipped with a dual axis compensator which will automatically correct both horizontal and vertical angles for any deviations in the plumb line. The system warns immediately of any deviations in excess of  $\pm 10^{\circ}$  ( $6'$ ).

## **Correction for Collimation Errors**

By carrying out a simple pre-measurement test procedure both horizontal and vertical collimation of the instrument can be quickly measured and stored. All angles measured thereafter are automatically corrected. These collimation correction factors remain in the internal memory until they are measured again.

## **Correction for Trunnion Axis Tilt**

During the same pre-measurement test procedure, it is also possible to measure and store angular imperfections of the horizontal tilt axis relative to the horizontal axis. This stored correction factor is applied automatically to all measured horizontal angles.

### **When should these tests be carried out?**

1. After transport where hard handling may have occurred.
2. When the temperature differs by  $> 10$  C from the previous application.
3. If you have changed the keyboard unit configuration since the latest calibration.(You can use one, two or no key board unit).
4. Immediately prior to high precision angle measurement.

### **How are these tests carried out?**

See “Test Measurements”, Geodimeter CU User Guide General part 1.

## Single-Face Angle Measurement

The above described features admits efficient and accurate angle measurement in a single face, since the instruments errors are automatically corrected with constants which were stored during the test measurement.

During Single Face angular measurements, with the compensator engaged and pre-measurement and storage of collimation and tilt axis errors have been executed, each displayed angle will be compensated for the following:

- Horizontal and vertical circle graduation and eccentricity errors.
- Plumb line deviation errors.
- Horizontal and vertical collimation errors.
- Tilt axis errors.

It is worth mentioning that human error sources such as telescope sighting (these errors can be almost nullified by measuring in two faces) and imperfections in the optical plummet of the tribrach still remain.

## Two-Face Angle Measurement

The instrument can be used in exactly the same manner as a conventional theodolite, i.e. in both the left and right face. These two-face situations will hereafter be referred to as Circle 1 and Circle 2 positions. Two face measurements can be used for legal reasons, or when additional concern of accuracy and documentation is demanded.

When measuring in STD-mode you measure and store each angle value of the two faces and get a display value of the total collimation and sighting error.

### 3 Angle Measurement System

---

When measuring in D-bar mode you can decrease the sighting error by repeating measurements and mean value calculation of each sighting. The number of repeated sightings can be chosen depending on the current measuring conditions. The final mean value calculated angles are displayed and stored in this mode. Angle values for each face are also available.





## Distance Measurement System

Overview .....	4-3
Distance Measurement .....	4-3
Automatic control of signal level .....	4-4
Measurement range and accuracy .....	4-4





## Overview

The distance module of Trimble 5600 Series operates within the infrared area of the electromagnetic spectrum. It transmits an infrared light beam. The reflected light beam is received by the instrument and, with the help of a comparator, the phase delay between transmitted and received signal is measured. The time measurement of the phase delay is converted and displayed as a distance with mm accuracy.

*Note – When taking measurements with servo instruments and having the Tracker installed there may be a distance error if you use large prisms.*

## Distance Measurement

The internal function of the distance measurement module can be varied depending on the nature of the particular survey application in question. There are four methods of distance measurement



Standard measurements towards stationary targets (standard mode)



Fast measurements towards stationary targets (fast standard mode)



Precision measurements towards stationary targets (arithmetical mean value D-bar mode)



Measurements towards moving targets (tracking mode) e.g setting out or hydrographic surveying. Also functions as automatic measuring mode for polar measurement and tacheometry.

The choice of measurement method is often based on the experience of the operator and of course the practical precision demanded by the current survey task.

### **Automatic control of signal level**

The Trimble 5600 Series instruments have an automatic signal control which adjusts the measurement signal level to an optimal value of each distance measured.

### **Measurement range and accuracy**

Since the Trimble 5600 Series instruments are constantly improved we refer to the Technical Specifications sheets for the up-to-date measurement range and accuracy figures of the respective models.

Geodesical

## Servo

Overview .....	5-2
Servo controls .....	5-2
Motion knobs.....	5-2



## Overview

The Trimble 5600 Series instruments are equipped with servo controlled motors for positioning of the unit. The servo is in use when performing a number of different operations; when turning the motion knobs, when positioning with the servo control keys, for automatic test and calibration or when using the tracker for robotic surveying.

## Servo controls

### Motion knobs

The servo is manually controlled by the two motion knobs located at the side of the instrument.

The motion knobs are sensitive in four steps so that the more you turn the knob the faster the servo will rotate the instrument.

If you want to switch to fine mode adjustment when operating a motion knob, turn the opposite direction and fine adjust.

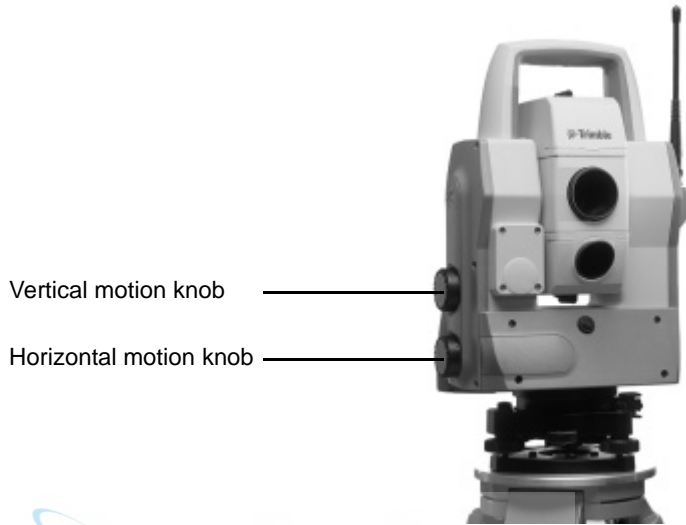

Vertical motion knob

Horizontal motion knob

 **Geodesical**





# Tracklight

Overview .....	6-3
Changing the bulb.....	6-4



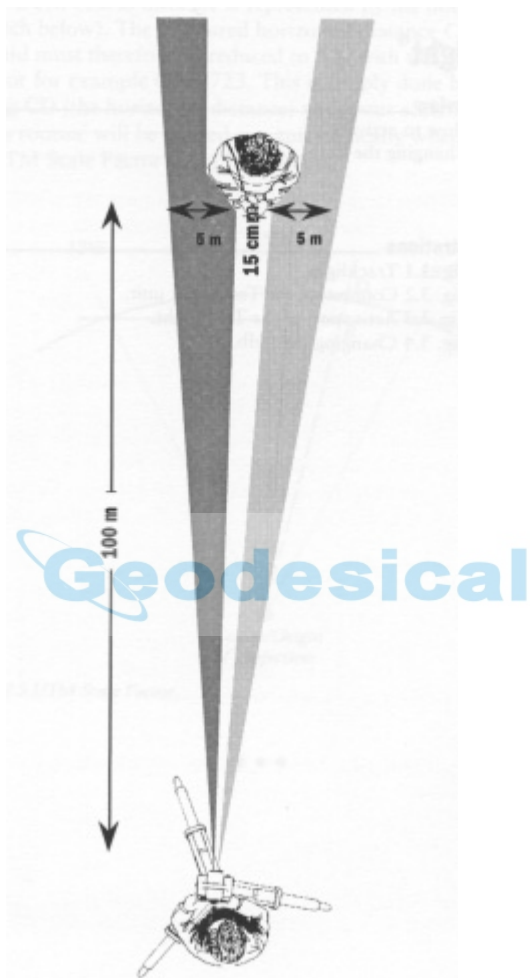

Figure 6.1 Tracklight<sup>®</sup> emits a red, white and green sector of flashing light where the white light coincides with the measuring beam.

## Overview

Tracklight is a visible guide light which enables the rodman to set himself on the correct bearing. It consists of a flashing three coloured light, each colour lying within its own lateral projection sector. If the rodman is to the left of the measuring beam, he will observe a green flashing light; if to the right, a red flashing light; if on-line with the measuring beam of the instrument, a white flashing light.

The frequency of the flash will increase by 100% as soon as the light beam strikes the reflector, which will confirm for the staff – man that he/she is holding the rod in the correct position. Once the rodman is on-line, the distance will immediately appear on the display. Tracklight also provides the operator with an excellent facility for clearing sight lines and for working during the hours of darkness.

From the figure on previous page, it can be seen that the instrument measuring beam width at 100 m is 15 cm. The width of the tracklight beam at the same distance is 10 m.

The tracklight unit slides onto the underside of the measuring unit (see fig figure 6.2) and it is activated from the keyboard.



Figure 6.2 The Tracklight unit slides onto the underside of the measuring unit.

## Changing the bulb

In order to change the tracklight bulb, open the cover under which the bulb is situated.

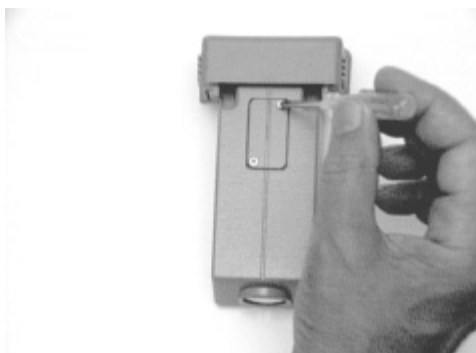

Remove very carefully the bulb housing and replace the spent bulb with a new one. Replace the bulb housing and connect the cover with the screwdriver (figure 6.3).



Figure 6.3 The sketch shows how the Tracklight bulb (6.3V/0.2A) should be removed from the connection socket.



# Tracker

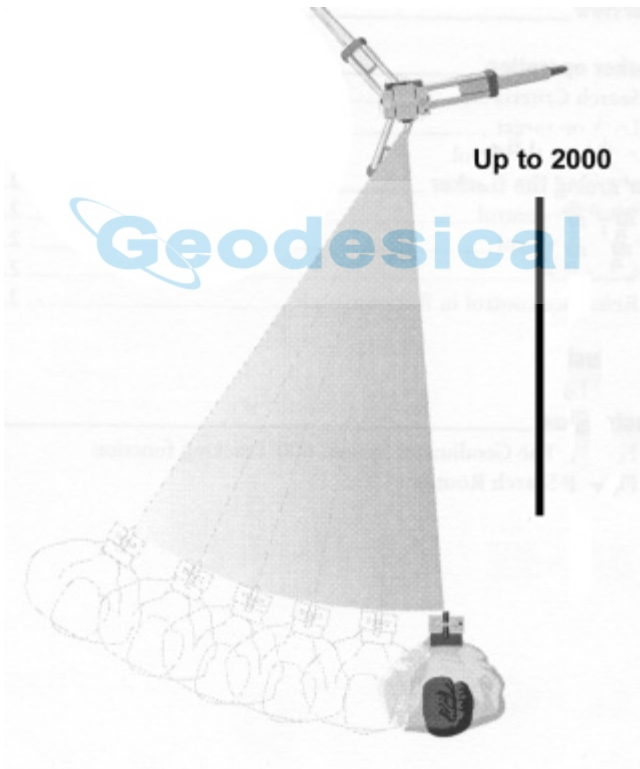

Figure 7.1 The Trimble 5600 Series Tracking function.

## Overview

Trimble 5600 Series can be equipped with a Tracker unit which is needed when using the system for robotic surveying or when performing conventional surveying with Autolock.

The tracker has control over the instrument's servos and aims the instrument correctly towards the target, which in these cases must be an RMT (Remote Target). An automatic search function is optional.





## Beam adjustment

Laser beam DR Standard.....	8-2
Overview .....	8-2
Alignment .....	8-2
Adjustment .....	8-4
Laser Pointer DR 200+ & DR 300+.....	8-6
Overview .....	8-6
Alignment .....	8-6
Adjustment.....	8-7

## Laser beam DR Standard

### Overview

The red laser beam used for measuring without reflector is coaxial with the line of sight of the telescope. If the instrument is well adjusted, the red measuring beam will coincide with the visual line of sight. External influences such as shock or large temperature fluctuations can displace the red measuring beam relative to the line of sight. The measuring beam is also used as a laser pointer.

### Alignment

Check the system at regular intervals in order to avoid faulty measurements with the provided adjustment target. Set up the adjustment target between 25 and 50 metres away facing the instrument. Switch on the red laser beam by activating the laser pointer function. Direct the instrument to the centre of the target plate and then inspect the position of the red laser spot with respect to the hair cross of the instrument. If the red laser spot lies outside the

limits of the cross, the direction of the beam needs to be adjusted until it coincides with the hair cross.

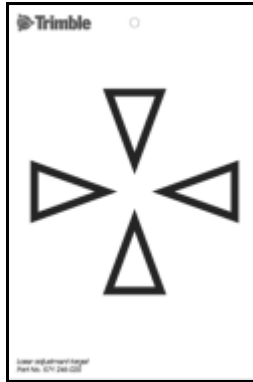

**Attention!** Viewing the laser spot on the adjustment target through the telescope is safe. Do not try to make the adjustment using a prism.

**Tip!** The direction of the beam should be inspected before precise measurement of distances is attempted, because an excessive deviation of the laser beam from the line of sight can result in imprecise distance measurements.

## Adjustment

Pull the two plugs out of the adjustment ports on the top of the telescope housing.

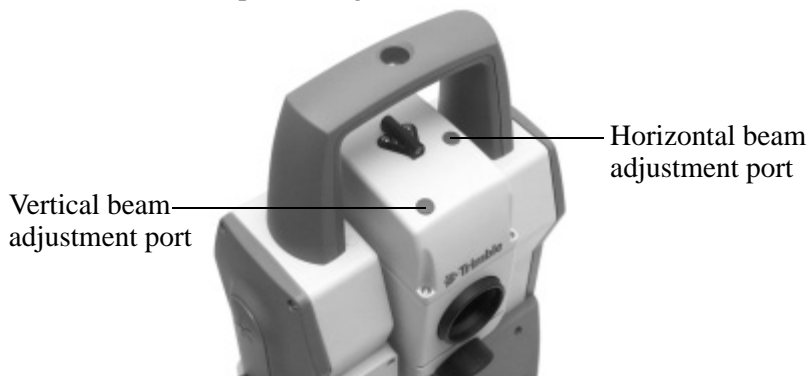

To correct the vertical position of the laser spot, insert the allen key into the vertical adjustment port and turn it.



To correct position of the laser spot horizontally, insert the allen key into the horizontal adjustment port and turn it.



Finally check the coincidence of laser spot and hair cross. Throughout the adjustment procedure, keep the telescope pointing to the adjustment target. The adjusting screws are of a high tension as they are self blocking. The screws will tighten automatically after the adjustment.

**Attention!** Make sure that the plugs are correctly in place in the adjustment ports to keep out humidity and dust.

## Laser Pointer DR 200+ & DR 300+

### Overview

Trimble 5600 DR 200+ & DR 300+-series can be equipped with an optional Laser Pointer. The Trimble 5600 DR 200+ & DR 300+ Series instrument with Laser Pointer has been tested and complies with the regulations for a class 2 Laser product, see laser safety information on the first pages of this manual

### Alignment

The Laser Pointers alignment can be checked and if needed adjusted. Tools for alignment are supplied with the instrument, see figure below.

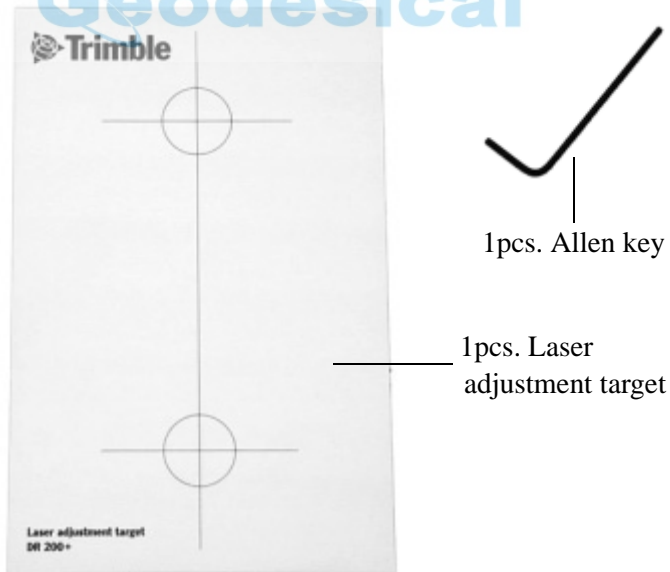

Figure 8.1 Laser pointer adjustment tools

## Adjustment

Mount the Laser adjustment target vertically aligned at a distance of about 10m or more from your instrument, at the same height as your instrument.

Power up the instrument, set the instrument in Direct Reflex mode and switch on the laser pointer.

Align the telescope haircross with the lower reference cross on the target.

Adjust the Laser Pointer beam with the horizontal and vertical adjustment screws until the laser point is centred on the upper reference cross on the target. See figure below.



Figure 8.2 Laser Pointer adjustment screws





# Radio

Overview .....	9-3
Radio controls .....	9-3
Select radio channel .....	9-3
Station address .....	9-3
Radio license .....	9-4
Range .....	9-4





Figure 9.1 The Trimble 5600 Series with radio side cover.

## Overview

To be able to communicate between the instrument and the RPU the instrument must be equipped with a radio side cover and the keyboard unit must be connected to an external radio. The radio side cover consists of a built in radio and an antenna.

## Radio controls

### Select radio channel

The radio channel is selected from the Control Unit. Up to 12 channels can be used depending on how many are supplied or permitted by authorities in each country. Select a channel when the CU is attached to the instrument. Then when the CU is detached and connected to the external radio, this radio will automatically get the same channel as the instrument. The range of different channels makes it possible to work with more than one Trimble 5600 at a working site. It is though important that each system has its own radio channel so that not any disturbances will occur.

### Station address

If disturbances occur on the radio channel from other systems in the same area, try to change channel. If that does not help the instrument and the RPU can be given an unique address. Choose menu 1.5, Radio with the keyboard unit attached to the instrument. Here you are prompted to enter a station address and a remote address between 0 and 99.

### Radio license

Note that the radio frequencies used are not harmonized within EC and only permitted in one particular country or area. Make sure that your radio is intended for the country, where it is to be used. The information of destination country can be found on the External radio or on its package.

Before using the system at your working site it is important to know that in some countries it is necessary to have a user license. Make sure that your local agent has informed you about the regulations in your country.

### Range

The actual range in which the radio can work is depending on the conditions. Range can be decreased if other radios are in operation in your area or when you are working in an area with many reflecting objects.

## Power Supply

Batteries .....	10-2
Internal Battery unit (Central unit) .....	10-2
External Battery/Radio Battery.....	10-2
Single Adapter .....	10-3
Multi Adapter .....	10-3
Battery Cables .....	10-4
Battery Charging .....	10-5
Power Unit (571 906 146).....	10-6
About charging NiMH (and NiCd) batteries.....	10-6
Bat Low .....	10-6

## Batteries

### Internal Battery unit (Central unit)

The internal NiMH 12 V, 1.6 Ah battery unit (Part Nr. 571 242 460) slides into the underside of the measuring unit. This is the standard battery for the measuring unit.



Figure 10.1 Battery unit 12V for central unit.

### External Battery/Radio Battery

The external NiMH 12V, 3.5 Ah battery (Part No. 571 204 270), which is also common to other Spectra Precision products, is connected to the instrument via the Single Adapter (Part No. 571 204 256) or Multi Adapter (Part No. 571 204 273) described below and a standard Hirose cable. The battery also fits directly on the External Radio.



Figure 10.2 External Battery/ Radio Battery, 12V, 3.5 Ah

### Single Adapter

The Single Adapter (Part No. 571 204 256) is used when you want to connect the External NiMH Battery (Part No. 571 204 270) to the Trimble 5600 Series instrument via a standard Hirose cable. The adapter slides onto the upper side of the External Battery. The adapter has two Hirose connectors and a bracket for attaching it to a tripod.

### Multi Adapter

The Multi Adapter (Part No. 571 204 273) is used to connect up to three External NiMH Battery units (Part No. 571 204 270) to the Trimble 5600 Series instrument via a standard Hirose cable. The adapter slides onto the upper sides of the External Batteries. The adapter has 2+2 Hirose connectors and a bracket for attaching it to a tripod. Three External Batteries will result in a total capacity of 10.5 Ah!

## Battery Cables

The multi functional cable is required if an external battery is used or when connecting the different Spectra Precision devices with each other. The different types of cables are listed below:

**Multi functional Cable 1m, 571 202 188**, for connecting the Trimble 5600 Series instrument or control unit to an external battery via the Single or Multi Adapter or to another control unit or instrument. Length: 1.0m.

**Multi functional Cable 2.5m, 571 202 216**, same as the above cable. Length: 2.5m.

**Multi functional Cable 0,4m, 571 208 043**, same as the above cable. Length: 0.4m.

**Multi functional spiral cable 0.75-1.75m, 571 208 068**, same as the above cable. Length: 0.75-1.75m.

**Data Communication Adapter, 571 202 204**, for connecting the Trimble 5600 Series instrument or control unit to a computer and Power Supply or an external battery using the Single or Multi Adapter.



## Battery Charging

Trimble AB produces special NiMh and NiCd battery chargers which should always be used when charging Trimble batteries. The system contains the following different types of units:

### Single Charger (571 906 330)

A 230 or 115 VAC single battery charger. The charger has a single Hirose output that can handle one NiMH External Battery (571 204 270). Use together with Power Cable 571 905 925 (100-115V), 571 905 924(220V) or 571 908 040 (230V, UK plug) and Charger Cable 571 208 020 (for other batteries).

### Super Charger (571 906 145)

A microprocessor controlled charger for sequential charging of up to four Trimble NiMH or NiCd batteries. It is run with 10-30 VDC and is fitted with a connector to suit both 19mm and 12mm cigarette lighter sockets. It shall only be used together with Trimble Power Unit (571 906 146). The ambient temperature while charging should be between +0 C and +40 C. Use together with Charger Cable 571 208 020 (for other batteries).

---

**Warning** – The Super Charger is for use together with Power Unit 571 906 146 only! Other power units or charging converters must never be used together with Super Charger.

---

## Power Unit (571 906 146)

A 90-260 VAC charging converter for use together with Super Charger (571 906 145). The Power Unit is equipped with a cigarette lighter socket and two Hirose connectors for Trimble 5600 Series system cabling. Use together with Power Cable 571 905 924 (230V), 571 905 925 (100-115V) or 571 908 040 (230V, UK plug).

## About charging NiMH (and NiCd) batteries

The temperature while charging should be above +5 C but should not exceed room temperature. The condition of the battery will be better preserved if it is used until the Trimble 5600 indicates “Bat Low” and the automatic cut-out function is activated. Discharge of stored batteries can vary considerably, depending on the quality of the individual cells, especially at higher temperatures. It is therefore recommended to store them in room temperature or lower and recharge batteries if they have been stored for a longer period than two one month.

*Note – Please refer to the battery chargers instructions.*

## Bat Low

When battery capacity drops too low, “Bat Low” appears in the display window, and the instrument shuts off automatically. This gives you an opportunity to change the battery without losing instrument parameters and functions such as instrument height, signal height, coordinates, bearing, dual axis compensation, etc. Note that the battery change must be made within 2 hours; otherwise the above parameters and functions will be reset.

***Note** – This safety backup of the instrument’s parameters and functions will work only when “Bat Low” appears on the display: It will not function if the battery is removed during operation.*





## Care & Maintenance

Overview .....	11-2
Cleaning .....	11-3
Condensation .....	11-3
Packing for Transport .....	11-3
Warranty .....	11-3
Service .....	11-4



## Overview

Trimble 5600 Series is designed and tested to withstand field conditions, but like all other precision instruments, it requires care and maintenance.

- Avoid rough jolts and careless treatment.
- Keep lenses and reflectors clean. Always use lens paper or other material intended for cleaning optics.
- Keep the instrument protected in an upright position, preferably in its transport case.
- Don't carry the instrument while mounted on the tripod in order to avoid damage to the tribach screws.
- Servo instruments only: Do not rotate the instrument by the handle. This may have an affect on the HA ref. How much it effects the value depends on the quality of the tribach and the tripod. Use instead the servo controls to rotate the instrument.
- Don't carry the instrument by the telescope barrel. Use the handle.
- When you need extremely good measurement precision, make sure the instrument has adapted to the surrounding temperature. Great variations of instrument temperature could affect the precision.

---

**Warning** – Trimble 5600 Series is designed to withstand normal electromagnetic disturbance from the environment. However, the instrument contains circuits sensitive to static electricity and the instrument cover must not be removed by unauthorized personnel. If the instrument cover has been opened by an unauthorized person, the function of the instrument is not guaranteed and the instrument warranty becomes invalid.

---

## **Cleaning**

Caution must be exercised when the instrument is cleaned, especially when sand and dust are to be removed from lenses and reflectors. Never use coarse or dirty cloth or hard paper. Anti-static lens paper, cotton wad or lens brush are recommended. Never use strong detergents such as benzine or thinner on instrument or case.

## **Condensation**

After survey in moist weather the instrument should be taken indoors, the transport case opened and the instrument removed. It should then be left to dry naturally. It is recommended that condensation which forms on lenses should be allowed to evaporate naturally.

Geodesical

## **Packing for Transport**

The instrument should always be transported in its transport case, which should be locked.

For shipment to a service shop, the names of the sender and receiver should always be specified clearly on the transport case.

When sending this instrument for repair, or for other service work, a note describing fault, symptoms or requested service should always be enclosed in the transport case.

## **Warranty**

Trimble AB guarantees that the instrument has been inspected and tested before delivery. The length of the warranty is stated in the Warranty Conditions.

All enquiries regarding the warranty should be directed to the local Trimble representative.

### **Service**

We recommend that you, once a year, leave the instrument to an authorized Trimble service workshop for service. This is to guarantee that the specified accuracies are maintained. Note that there are no user servicable parts inside the instrument.





## Card Memory

Overview .....	12-2
Installation .....	12-2
How to connect to a Trimble 5600 Series instrument .....	12-2
How to insert the memory card .....	12-5
Memory Card .....	12-8
Handling hints .....	12-9

Geodesical

## Overview

*Note – The Card Memory only operates together with the Geodimeter CU Control Unit.*

The optional Card Memory (P71 222 000) opens the possibility of storing measurement data on portable PCMCIA, ATA Sundisk memory cards. These can then be transferred between the instrument and a PC and vice versa without having to bring the instrument with you.

## Installation

### How to connect to a Trimble 5600 Series instrument

You can attach the Card Memory unit in two ways:

1. If you have to have Panel Attachment at the front of the instrument, that is the side opposite to the operator, you

can attach the Card Memory unit to the instrument in the same way as the ordinary keyboard unit.



Figure 12.1 How to attach the card memory on an instrument

2. You can also hang the Card Memory while in this case on the tripod and attach it to the foot connector on the instrument with the system cable, see page 10-4.



Figure 12.2 How to connect the card memory using the system cable.

## 12 Card Memory

---

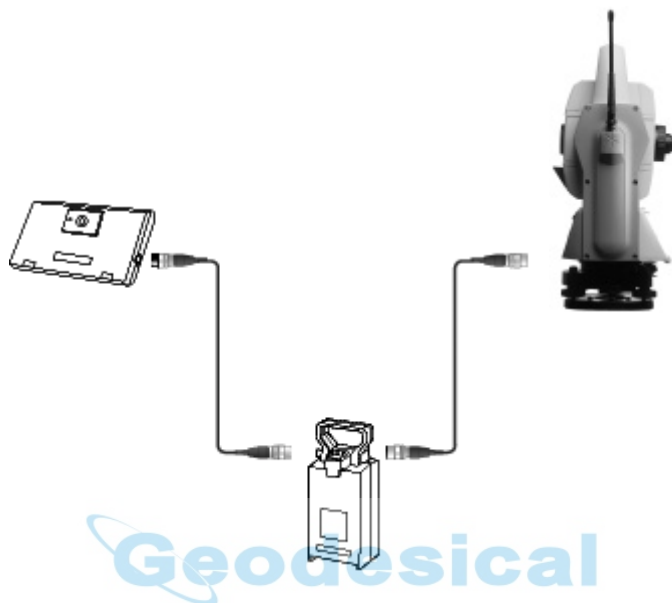

Figure 12.3 Attach the card memory to a battery with 2 connectors.

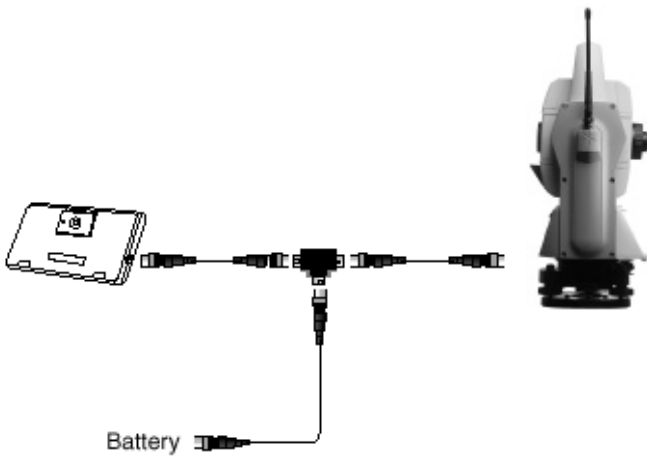

Figure 12.4 Attach the card memory to a battery with 1 connector with the help of the T-connector.

## How to insert the memory card

To insert the memory card into the Card Memory please do the following:

1. Open the Card Memory door.
2. Turn the memory card so that you can read the Geodimeter logotype from left to right.
3. Insert the card into the card slot until you hear a click.
4. Shut the Card Memory door until you hear a click.

## 12 Card Memory

---



Figure 12.5 How to insert the memory card into the card memory device.

To replace the memory card do the following:

1. Open the Card memory door.
2. Press the small knob in to the card slot until the memory card is ejected.
3. You can now take the card and shut the Card Memory door.



## Memory Card

The memory card for the Card Memory must be a type called PCMCIA. It can be read from any card reader that can handle PCMCIA cards of ATA, Sandisk type.



Figure 12.6 Trimble Memory Card

### Capacity

The card can store up to 32 MB of measurement data.

### Memory structure

The memory card can be use to store two types of data: survey measurements (Job files) and known coordinates (Area files). These Job- and Area-files consist of separate expansive submemories which means that they can be updated individually at any time without affecting other Job- and Area-files. The total number of files is limited to the total capacity of the memory. The more raw data stored in Job files, the less known coordinate and elevation data that can be stored in Area files and vice versa. The files name can be max. 8 characters and with 3 characters for the



extension, e.g. TESTFILE.JOB. When you load files from a computer to a memory card, you must load all the files under the root catalogue if you wish to use the files in your instrument.

## Handling hints

- The Card Memory device is always the last device in the serial chain. When having it attach on the panel attachment you cannot communicate via the foot connector.
- If you intent to have the Card Memory device attached prior to starting the instrument, otherwise you cannot communicate with it.
- If you have formatted a memory card yourself, you can expect the access time to be a little longer than usual, the first time you try to access the card.
- When using the editor and accessing large files from the memory card, you can expect longer access times than when handling files from the internal memory.
- It is recommended that you keep the Card memory door closed at all times except when inserting the memory card and that you take the device indoors after survey in moist weather. It should then be left to dry naturally.
- If you have two keyboard panels attached to the instrument at the same time, you cannot access the Card memory.

*Note – Trimble AB cannot be held responsible for any type of memory loss using the card memory.*



## RMT Remote Targets

In General .....	13-2
RMT 602 .....	13-3
RMT 606 .....	13-4
RMT 600 TS.....	13-5
RMT Super Multi Channel.....	13-7
RMT SLR .....	13-8



## In General

Trimble 5600 series (servo) instruments equipped with an optional Tracker unit can perform surveying tasks using the Autolock function. If the instrument is upgraded with a radio, you will also be able to perform Robotic surveying, i.e one-person surveying. To be able to use the above functions you must also use some type of Remote Measuring Target (RMT). A Trimble Remote Measuring Target consists of a prism reflector and one or several active tracker diodes. The great advantage of using active tracker diode(s) is that you eliminate the risk of the instrument locking on to other reflecting objects than the RMT. Today there are five different models of RMT to choose between for Trimble 5600 series. All RMT models complies with the regulations for a Class 1 LED device.

*Note – The typical range of the different RMT models is depending on the weather conditions.*

## RMT 602

RMT602 (Part No. 571 202 220) is the standard remote target for Trimble 5600 series. It can be used for distances up to 350 m and consists of a tracker diode unit with a miniature prism (Part No. 571 126 060) mounted in front (not included). The RMT602 remote target is powered by two standard 1.5V size LR6/AA replaceable batteries which fits into the unit. RMT602 can also be powered externally via the Hirose contact.



RMT602 Mounted  
in a tiltable holder  
Part.no:571 202 434

RMT602

## RMT 606

RMT606 (Part No. 571 204 610) is a 360° remote target for Trimble 5600 series. It can be used for distances up to 350 m. The RMT consists of a tracker diode unit with a set of active diodes forming a full 360 degree circle and a 360° prismring (Part No. 571 204 312)(not included). The RMT606 remote target is powered externally via the Hirose contact or directly from the power pole.



## RMT 600 TS

RMT600TS (Part No. 571 204 240) is basically a tiltable RMT602 equipped with a vertical angle sensor. It can be used for distances up to 700 m. The prism is not included. The RMT600TS sends its current vertical angle via the RPU radio to the instrument. This way the instrument automatically tilts its telescope to the correct vertical angle. This saves a lot of searching time, especially when working in areas or applications where elevation is changed frequently. RMT600TS is powered externally via its Hirose connector from the RPU radio battery (it is possible to use RMT600TS's internal batteries when working with Autolock). Do as follows to set up RMT600TS (it is assumed that you have carried out the robotic start procedure): connect the Georadio from connector A to the *control unit holder* 571 204 242. Connect RMT600TS to the other connector of the *control unit holder*. Switch on the control unit, step through the start-up procedure and wait for the control unit to establish contact with the instrument. The RMT600TS automatically switches on after a short while.

**Note** – *Do not use the control unit's internal input/output.*

Now tilt the RMT towards the instrument as you view through its coarse sight. Press the key on the control unit and the instrument automatically starts searching for your RMT at the correct vertical level. When the instrument has found the RMT it locks on and follows it as you move.

**Note** – *Remember to define a “search window” before you begin the robotic surveying.*

**Note** – *Error 241: The first time you switch on RMT600TS you may get the error message “Error 241 The RMT needs index” as you press the key. This means that the control unit*

### 13 RMT Remote Targets

---

*doesn't receive any vertical angle reference from the RMT. To fix this just tilt the RMT past the vertical plumb line and back again – then press again. Now the instrument will begin searching for your RMT.*





## RMT Super Multi Channel

RMT SUPER Multi Channel (Part no 571 233 035) consists of a prism ring with seven 1" prisms and an RMT with a set of active diodes forming a full 360 degree circle. It can be used for distances up to 700 m. The RMT can be set to four different target channel IDs. Use channel 4 (Standard) with any Trimble 5600 series or Autolock instrument. Or use any channel setting with Trimble 5600 series with multi channel capability. Make sure to set the instrument to the same channel ID setting. The RMT SUPER Multi Channel has been developed for dynamic operation with the Trimble ATS instruments. For optimum slope distance accuracy in static operation, make sure to turn the prism ring so that one of the prisms is aimed towards the instrument when the distance is measured.



## RMT SLR

The RMT SLR (Part no 571 204 360) is a target combining accurate short-range measurement with long-range capacity. This is achieved by using two different modes of operation. A short-range mode utilizes a single diode of the same type used in the RMT 602 (571 202 220), It can be used for distances up to 350 m. The long range mode utilizes 5 long range diodes, placed in a circle, It can be used for distances up to 1500 m.

**PWR button:**

Sets the unit on/off. A flashing green light indicates when the RMT is switched on.

**LR button:**

Sets long-range mode. A fixed orange light indicates when the RMT is in long-range mode. A flashing orange light indicates that an external battery must be connected to the RMT or that the external battery needs to be exchanged.

***Note** – For long range mode an external battery must be connect to the RMT.*

The target has multi channel capability. The white dot on the circular switch visible through the left part of the glass window indicates which channel ID the target is set to. The target ID numbers are printed on the circuit board.

The channel setting can be changed. This should be done in a dry and clean place. It is not suitable to do this in the field.

To change the channel ID on this target, remove the front cover held in place by the six screws. Be careful not to lose the screws. Turn the switch to the desired position using a small screwdriver. Before putting the cover back make sure

the rubber seal is in its groove. Put the cover back and tighten the screws.

The RMT SLR can be used with the following prisms (not included):

571 126 060 for range up to 1000 m.

571 125 021 for range above 1000m.





## Machine Control & Guidance

Start up procedures.....	14-2
Georadio and Machine Control .....	14-3
Setting of radio channel and addresses.....	14-3
Remote operation and station establishment.....	14-3
Auto search.....	14-4
Distance meter calibration .....	14-5
RMT ATS Multi Channel .....	14-6

 Geodesical

If you have purchased a Trimble ATS, the instrument can be controlled from Trimble Blade Pro 3D™ software or a third party application for machine control or machine guidance.

How the Trimble ATS is used in a machine control application is application dependent.

Controlling applications must use the C&C600 language syntax to control the ATS in machine control and machine guidance applications. In the Trimble ATS and 5600 series the C&C600 language syntax is standard. The documentation of the language syntax is available for third party system integrators after approval and signing a NON-Disclosure agreement with Trimble AB.

## Start up procedures

Start Up procedures are application dependent. Please refer to the application software user instructions to determine the proper start-up procedure for your machine control or machine guidance application.

Some applications require that station establishment is made using the built in station establishment software of the Trimble ATS CU while other applications require only that the instrument is set up on a tripod, levelled and started up by pressing the button on the front of the alidade. In such case the station establishment must be made in the application software and radio channel and addresses must be set using an external application or by using the CU. For setting the channel and addresses from the CU please see below.

---

## **Georadio and Machine Control**

When using the Trimble ATS for machine control the radio requires the radio channel 100% of the time when the system is in use. It is not possible to share a channel with another user running another system simultaneously. Use a scanner to establish that the channel is free. You may need a licensed channel of your own to be able to work undisturbed.

## **Setting of radio channel and addresses**

Make sure the radio channel and addresses are set to the same values in the Trimble ATS as in the application software. To set the radio channel and addresses using the CU, see Chapter 9 or refer to the application software user instructions if the application is using the ATS without CU. If the application program does not use radio addressing then set both Station Address = 1 and Remote Address = 1.

## **Remote operation and station establishment**

If you use the Trimble ATS with an application software that requires the station establishment be made using the built in station establishment software (P20) then please refer to the Geodimeter CU User Guide Software manual. It is described how to start the Trimble ATS for robotic operation and the same procedure is used when starting it up for machine control. The Geodimeter CU User Guide Software manual will guide you further through, to the parts describing the station establishment procedure.

## Auto search

The Trimble ATS has built in automatic search capability that is activated automatically if the signal is lost when the system is running in machine control mode. This system has to be activated by the application software in order to work as intended.

If the Auto search system is active then it will search for the target as follows:

The description is valid for firmware version 696-02.01.

When the target is lost the system will search within the search sector with a number of horizontal scans at the vertical angle where the signal was lost. The number of scans is set to five by default but the application software may exclude them or set any number of scans up to 50 or maximum two minutes. If the target is not found during these horizontal scans then a spiral search will start. The spiral search will cover the sector that has been set from the CU or if the sector set from the application software the sector specified by the application software. If the target is brought outside the set sector limits with target lock maintained, then the sector may be centred at the angle where the target is lost. Also this feature is controlled from the application software.

If no target is found then the Trimble ATS will return to the position where the signal was lost and report to the application software that no target was found.

**Note!** It is important that the vehicle stops and stands still when the instrument is in auto search. It must remain still until target lock is achieved.



---

## **Distance meter calibration**

In order to achieve as high accuracy as possible the distance meter should be calibrated regularly by the application software. How often this must be done is application dependent. These distance meter calibrations will be seen as loss of signal for up to two seconds. Please refer to the application software documentation for more information on how often and under which circumstances these calibrations are made.



## RMT ATS Multi Channel

The Trimble ATS uses a 360 degree target. This sketch shows the dimensions of the target and to where signal height is measured. Signal Height is measured to the centre of the prism ring.

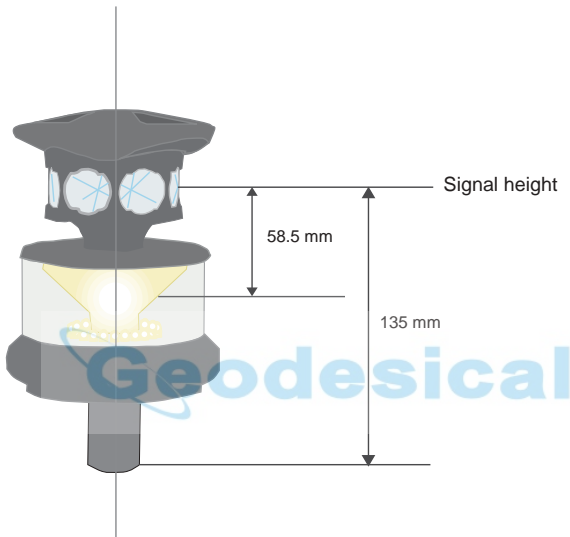

Figure 14.1 RMT ATS Multi Channel.

“The RMT ATS Multi Channel is designed for operation at distances up to 1000 m (700 m in robotic and ATS modes). In dynamic operation at distances less than 3 m, signal to the distance meter may be lost depending on the rotation of the prism ring in relation to the instrument. At distances from 3 m up to 8 m there may be an error in slope distance of up to 15 mm at 3 m and decreasing as the distance increases. This distance error can usually be neglected except at steep vertical angles or when used in an application where accurate horizontal position data is of importance”.

 **Geodesical**

The word "Geodesical" is written in a bold, blue, sans-serif font. A thin, light blue line forms a partial circle around the letter "G", starting from the top and curving around to the left.



Trimble Engineering and Construction Division  
5475 Kellenburger Road  
Dayton, Ohio 45424  
U.S.A.

800-538-7800 (Toll Free in U.S.A.)  
+1-937-233-8921 Phone  
+1-937-233-9004 Fax

[www.trimble.com](http://www.trimble.com)