

THALES



Z-Max[®].Net

REFERENCE MANUAL

Preliminary Document
May 24th 2006

Copyright Notice

Copyright 2003-2006 Thales Navigation. All rights reserved.

Trademarks

All product and brand names mentioned in this publication are trademarks of their respective holders.

FCC Notice

Z-Max Receiver complies with the limits for a Class B digital device, pursuant to the Part 15 of the FCC rules when it is used in Portable Mode. See Note below related to Class B device. Class B digital devices NOTE: This equipment has been tested and found to comply with the limits for a Class B digital device, pursuant to Part 15 of the FCC Rules. These limits are designed to provide reasonable protection against harmful interference in a residential installation. This equipment generates, uses, and can radiate radio frequency energy and, if not installed and used in accordance with the instructions, may cause harmful interference to radio communications. However, there is no guarantee that interference will not occur in a particular installation. If this equipment does cause harmful interference to radio or television reception, which can be determined by turning the equipment off and on, the user is encouraged to try and correct the interference by one or more of the following measures:

- Reorient or locate the receiving antenna.
- Increase the separation between the equipment and receiver.
- Connect the equipment into an outlet on a circuit different from that to which the receiver is connected.
- Consult the dealer or an experienced radio/TV technician for help.

When Z-Max is used with an external power supply or connected to an external device using the USB port, it complies with the limits for a Class A digital device, pursuant to the Part 15 of the FCC rules. See Note below related to Class A device.

Class A digital devices NOTE: This equipment has been tested and found to comply with the limits for a Class A digital device, pursuant to Part 15 of the FCC Rules. These limits are designed to provide reasonable protection against harmful interference when the equipment is operated in a commercial environment. This equipment generates, uses, and can radiate radio frequency energy and, if not installed and used in accordance with the instruction manual, may cause harmful interference to radio communications. Operation of this equipment in a residential area is likely to cause harmful interference in which case the user will be required to correct the interference at his own expense.

Remark: Any changes or modifications not expressly approved by Thales Navigation, could void the right for user to operate the equipment.

RF Safety Exposure To Radio Frequency Energy (SAR)

Radio transmitting devices radiate Radio Frequency (RF) energy during its operation. RF energy can be absorbed into the human body and potentially can cause adverse health effects if excessive levels are absorbed. The unit of measurement for human exposure to RF energy is "Specific Absorption Rate" (SAR).

The Federal Communications Commission (FCC), Industrie Canada (IC), and other agencies around the world have established limits that incorporate a substantial safety margin designed to assure the safety of all persons using this equipment. In order to certify this unit for sale in the US, Canada and Europe this unit has been tested for RF exposure compliance at a qualified test laboratory and found to comply with the regulations regarding exposure to RF Energy. SAR was measured with the unit (GSM Module) transmitting at its maximum certified RF power. Often, however, during normal operation the unit (GSM Module) will transmit much less than maximum power. Transmit power is controlled automatically and, in general is reduced as you get closer to a cellular base station. This reduction in transmit power will result in a lower RF energy exposure and resulting SAR value.

The different versions of the UHF Transmitters are FCC and CE compliant.

FCC and CE RF Safety Statement

In order to comply with FCC and CE RF exposure safety guidelines as body-worn, normal use of unit, the following must be followed:

A distance of AT LEAST 2 inches (5 cm) of separation between the users body and the unit (GSM Module). In a normal use of the product we have at least this distance

A distance of AT LEAST 10 feet (3 m) of separation between the users body and the unit (UHF Transmitter). This distance has been defined taken into account the FCC and CE Requirements and the worst output power configuration.

Do NOT use the device in a manner such that it is in direct contact with the body (e.g. on the lap). Such use will likely exceed FCC RF safety exposure limits. See www.fcc.gov/ot/rfsafety/ for more information on RF exposure safety.

Antenna Care/Unauthorized Modifications

Use only the supplied integral antenna. Unauthorized antenna modifications or attachments could damage the unit and may violate FCC and CE regulations. Any changes or modifications not expressly approved by the party responsible for compliance could void the user's authority to operate the equipment.

Maximum Measured SAR Values (W/kg) for the GSM Module

Band: 1900 MHz
Body SAR: 0.016

SAR: ANSI/IEEE C95.1 1992
FCC OET Bulletin 65 Supplement C
1999/519/CE

Replacing the Thales U-Link Transmitter Power Fuse

The Thales U-Link transmitter is protected by a 4-A fuse inserted in the data/power cable. This Y-shaped cable is used to connect the U-Link transmitter to the Z-Max receiver via a 7-pin connector, and to the power battery.

Should you have to replace this fuse, please get a spare fuse, 4 A, fast acting, ATO type, and then do the following:

- Unplug the battery end of the data/power cable
- Open the fuse holder located along the data/power cable
- Extract the damaged fuse
- Insert the new fuse and then push the holder lid back into place
- Connect the data/power cable back to the battery.

Battery Charger / External Power Supply

The Power Module contains rechargeable lithium-ion battery cells and "smart" charging circuitry. Recharging the Power Module is done using the AC/DC power supply, included with the System. This power supply can also be used to provide power directly to the Z-Max through an external connector. The charger is designed to work with a 110-240 VAC power source and delivers 12 V DC of input voltage with at least 4-A current capability to the Power Module.

 Use of non-Thales power supplies for charging the Power Module is not recommended.

THALES NAVIGATION PROFESSIONAL PRODUCTS - LIMITED WARRANTY

(North, Central and South America)

Thales Navigation warrants their GPS receivers and hardware accessories to be free of defects in material and workmanship and will conform to our published specifications for the product for a period of one year from the date of original purchase. **THIS WARRANTY APPLIES ONLY TO THE ORIGINAL PURCHASER OF THIS PRODUCT.**

In the event of a defect, Thales Navigation will, at its option, repair or replace the hardware product with no charge to the purchaser for parts or labor. The repaired or replaced product will be warranted for 90 days from the date of return shipment, or for the balance of the original warranty, whichever is longer. Thales Navigation warrants that software products or software included in hardware products will be free from defects in the media for a period of 30 days from the date of shipment and will substantially conform to the then-current user documentation provided with the software (including updates thereto). Thales Navigation's sole obligation shall be the correction or replacement of the media or the software so that it will substantially conform to the then-current user documentation. Thales Navigation does not warrant the software will meet purchaser's requirements or that its operation will be uninterrupted, error-free or virus-free. Purchaser assumes the entire risk of using the software.

PURCHASER'S EXCLUSIVE REMEDY UNDER THIS WRITTEN WARRANTY OR ANY IMPLIED WARRANTY SHALL BE LIMITED TO THE REPAIR OR REPLACEMENT, AT THALES NAVIGATION'S OPTION, OF ANY DEFECTIVE PART OF THE RECEIVER OR ACCESSORIES WHICH ARE COVERED BY THIS WARRANTY. REPAIRS UNDER THIS WARRANTY SHALL ONLY BE MADE AT AN AUTHORIZED THALES NAVIGATION SERVICE CENTER. ANY REPAIRS BY A SERVICE CENTER NOT AUTHORIZED BY THALES NAVIGATION WILL VOID THIS WARRANTY.

To obtain warranty service the purchaser must obtain a Return Materials Authorization (RMA) number prior to shipping by calling 800-229-2400 (U.S.) or 408 615 3981 (International), or by sending a repair request on-line at <http://products.thalesnavigation.com/en/support/rma.asp>. The purchaser must return the product postpaid with a copy of the original sales receipt to the address provided by Thales Navigation with the RMA number. Purchaser's return address and the RMA number must be clearly printed on the outside of the package.

Thales Navigation reserves the right to refuse to provide service free-of-charge if the sales receipt is not provided or if the information contained in it is incomplete or illegible or if the serial number is altered or removed. Thales Navigation will not be responsible for any losses or damage to the product incurred while the product is in transit or is being shipped for repair. Insurance is recommended. Thales Navigation suggests using a trackable shipping method such as UPS or FedEx when returning a product for service.

EXCEPT AS SET FORTH IN THIS LIMITED WARRANTY, ALL OTHER EXPRESSED OR IMPLIED WARRANTIES, INCLUDING THOSE OF FITNESS FOR ANY PARTICULAR PURPOSE, MERCHANTABILITY OR NON-INFRINGEMENT, ARE HEREBY DISCLAIMED AND IF APPLICABLE, IMPLIED WARRANTIES UNDER ARTICLE 35 OF THE UNITED NATIONS CONVENTION ON CONTRACTS FOR THE INTERNATIONAL SALE OF GOODS. Some national, state, or local laws do not allow limitations on implied warranty or how long an implied warranty lasts, so the above limitation may not apply to you.

The following are excluded from the warranty coverage: (1) periodic maintenance and repair or replacement of parts due to normal wear and tear; (2) batteries and finishes; (3) installations or defects resulting from installation; (4) any damage caused by (i) shipping, misuse, abuse, negligence, tampering, or improper use; (ii) disasters such as fire, flood, wind, and lightning; (iii) unauthorized attachments or modification; (5) service performed or attempted by anyone other than an authorized Thales Navigations Service Center; (6) any product, components or parts not manufactured by Thales Navigation; (7) that the receiver will be free from any claim for infringement of any patent, trademark, copyright or other proprietary right, including trade secrets; and (8) any damage due to accident, resulting from inaccurate satellite transmissions. Inaccurate transmissions can occur due to changes in the position, health or geometry of a satellite or modifications to the receiver that may be required due to any change in the GPS. (Note: Thales Navigation GPS receivers use GPS or GPS+GLONASS to obtain position, velocity and time information. GPS is operated by the U.S. Government and GLONASS is the Global Navigation Satellite System of the Russian Federation, which are solely responsible for the accuracy and maintenance of their systems. Certain conditions can cause inaccuracies which could require modifications to the receiver. Examples of such conditions include but are not limited to changes in the GPS or GLONASS transmission.) Opening, dismantling or repairing of this product by anyone other than an authorized Thales Navigation Service Center will void this warranty.

THALES NAVIGATION SHALL NOT BE LIABLE TO PURCHASER OR ANY OTHER PERSON FOR ANY INCIDENTAL OR CONSEQUENTIAL DAMAGES WHATSOEVER, INCLUDING BUT NOT LIMITED TO LOST PROFITS, DAMAGES RESULTING FROM DELAY OR LOSS OF USE, LOSS OF OR DAMAGES ARISING OUT OF BREACH OF THIS WARRANTY OR ANY IMPLIED WARRANTY EVEN THOUGH CAUSED BY NEGLIGENCE OR OTHER FAULT OF THALES NAVIGATION OR NEGLIGENCE OF THE PRODUCT. IN NO EVENT WILL THALES NAVIGATION BE RESPONSIBLE FOR SUCH DAMAGES, EVEN IF THALES NAVIGATION HAS BEEN ADVISED OF THE POSSIBILITY OF SUCH DAMAGES.

This written warranty is the complete, final and exclusive agreement between Thales Navigation and the purchaser with respect to the quality of performance of the goods and any and all warranties and representations. This warranty sets forth all of Thales Navigation's responsibilities regarding this product. This limited warranty is governed by the laws of the State of California, without reference to its conflict of law provisions or the U.N. Convention on Contracts for the International Sale of Goods, and shall benefit Thales Navigation, its successors and assigns.

This warranty gives the purchaser specific rights. The purchaser may have other rights which vary from locality to locality (including Directive 1999/44/EC in the EC Member States) and certain limitations contained in this warranty, including the exclusion or limitation of incidental or consequential damages may not apply.

For further information concerning this limited warranty, please call or write:

Thales Navigation, Inc., 471 El Camino Real, Santa Clara, California 95050, Phone: +1 408-615-5100, Fax: +1 408-615-5200 or

Thales Navigation SA - ZAC La Fleuriaye - BP 433 - 44474 Carquefou Cedex - France Phone: +33 (0)2 28 09 38 00, Fax: +33 (0)2 28 09 39 39

THALES NAVIGATION PROFESSIONAL PRODUCTS LIMITED WARRANTY

(Europe, Middle East, Africa)

All Thales Navigation global positioning system (GPS) receivers are navigation aids, and are not intended to replace other methods of navigation. Purchaser is advised to perform careful position charting and use good judgment. READ THE USER GUIDE CAREFULLY BEFORE USING THE PRODUCT.

1. THALES NAVIGATION WARRANTY

Thales Navigation warrants their GPS receivers and hardware accessories to be free of defects in material and workmanship and will conform to our published specifications for the product for a period of one year from the date of original purchase or such longer period as required by law. THIS WARRANTY APPLIES ONLY TO THE ORIGINAL PURCHASER OF THIS PRODUCT.

In the event of a defect, Thales Navigation will, at its option, repair or replace the hardware product with no charge to the purchaser for parts or labor. The repaired or replaced product will be warranted for 90 days from the date of return shipment, or for the balance of the original warranty, whichever is longer. Thales Navigation warrants that software products or software included in hardware products will be free from defects in the media for a period of 30 days from the date of shipment and will substantially conform to the then-current user documentation provided with the software (including updates thereto). Thales Navigation's sole obligation shall be the correction or replacement of the media or the software so that it will substantially conform to the then-current user documentation. Thales Navigation does not warrant the operation will meet purchaser's requirements or that its operation will be uninterrupted, error-free or virus-free. Purchaser assumes the entire risk of using the software.

2. PURCHASER'S REMEDY

PURCHASER'S EXCLUSIVE REMEDY UNDER THIS WRITTEN WARRANTY OR ANY IMPLIED WARRANTY SHALL BE LIMITED TO THE REPAIR OR REPLACEMENT, AT THALES NAVIGATION'S OPTION, OF ANY DEFECTIVE PART OF THE RECEIVER OR ACCESSORIES WHICH ARE COVERED BY THIS WARRANTY. REPAIRS UNDER THIS WARRANTY SHALL ONLY BE MADE AT AN AUTHORIZED THALES NAVIGATION SERVICE CENTER. ANY REPAIRS BY A SERVICE CENTER NOT AUTHORIZED BY THALES NAVIGATION WILL VOID THIS WARRANTY.

3. PURCHASER'S DUTIES

To obtain service, contact and return the product with a copy of the original sales receipt to the dealer from whom you purchased the product.

Thales Navigation reserves the right to refuse to provide service free-of-charge if the sales receipt is not provided or if the information contained in it is incomplete or illegible or if the serial number is altered or removed. Thales Navigation will not be responsible for any losses or damage to the product incurred while the product is in transit or is being shipped for repair. Insurance is recommended. Thales Navigation suggests using a trackable shipping method such as UPS or FedEx when returning a product for service.

4. LIMITATION OF IMPLIED WARRANTIES

EXCEPT AS SET FORTH IN ITEM 1 ABOVE, ALL OTHER EXPRESSED OR IMPLIED WARRANTIES, INCLUDING THOSE OF FITNESS FOR ANY PARTICULAR PURPOSE OR MERCHANTABILITY, ARE HEREBY DISCLAIMED AND IF APPLICABLE, IMPLIED WARRANTIES UNDER ARTICLE 35 OF THE UNITED NATIONS CONVENTION ON CONTRACTS FOR THE INTERNATIONAL SALE OF GOODS.

Some national, state, or local laws do not allow limitations on implied warranty or how long an implied warranty lasts, so the above limitation may not apply to you.

5. EXCLUSIONS

The following are excluded from the warranty coverage:

- (1) periodic maintenance and repair or replacement of parts due to normal wear and tear;
- (2) batteries;
- (3) finishes;
- (4) installations or defects resulting from installation;
- (5) any damage caused by (i) shipping, misuse, abuse, negligence, tampering, or improper use; (ii) disasters such as fire, flood, wind, and lightning; (iii) unauthorized attachments or modification;
- (6) service performed or attempted by anyone other than an authorized Thales Navigations Service Center;
- (7) any product, components or parts not manufactured by Thales Navigation,
- (8) that the receiver will be free from any claim for infringement of any patent, trademark, copyright or other proprietary right, including trade secrets
- (9) any damage due to accident, resulting from inaccurate satellite transmissions. Inaccurate transmissions can occur

due to changes in the position, health or geometry of a satellite or modifications to the receiver that may be required due to any change in the GPS. (Note: Thales Navigation GPS receivers use GPS or GPS+GLONASS to obtain position, velocity and time information. GPS is operated by the U.S. Government and GLONASS is the Global Navigation Satellite System of the Russian Federation, which are solely responsible for the accuracy and maintenance of their systems. Certain conditions can cause inaccuracies which could require modifications to the receiver. Examples of such conditions include but are not limited to changes in the GPS or GLONASS transmission.).

Opening, dismantling or repairing of this product by anyone other than an authorized Thales Navigation Service Center will void this warranty.

6. EXCLUSION OF INCIDENTAL OR CONSEQUENTIAL DAMAGES

THALES NAVIGATION SHALL NOT BE LIABLE TO PURCHASER OR ANY OTHER PERSON FOR ANY INDIRECT, INCIDENTAL OR CONSEQUENTIAL DAMAGES WHATSOEVER, INCLUDING BUT NOT LIMITED TO LOST PROFITS, DAMAGES RESULTING FROM DELAY OR LOSS OF USE, LOSS OF OR DAMAGES ARISING OUT OF BREACH OF THIS WARRANTY OR ANY IMPLIED WARRANTY EVEN THOUGH CAUSED BY NEGLIGENCE OR OTHER FAULT OF THALES NAVIGATION OR NEGLIGENT USAGE OF THE PRODUCT. IN NO EVENT WILL THALES NAVIGATION BE RESPONSIBLE FOR SUCH DAMAGES, EVEN IF THALES NAVIGATION HAS BEEN ADVISED OF THE POSSIBILITY OF SUCH DAMAGES.

Some national, state, or local laws do not allow the exclusion or limitation of incidental or consequential damages, so the above limitation or exclusion may not apply to you.

7. COMPLETE AGREEMENT

This written warranty is the complete, final and exclusive agreement between Thales Navigation and the purchaser with respect to the quality of performance of the goods and any and all warranties and representations. THIS WARRANTY SETS FORTH ALL OF THALES NAVIGATION'S RESPONSIBILITIES REGARDING THIS PRODUCT.

THIS WARRANTY GIVES YOU SPECIFIC RIGHTS. YOU MAY HAVE OTHER RIGHTS WHICH VARY FROM LOCALITY TO LOCALITY (including Directive 1999/44/EC in the EC Member States) AND CERTAIN LIMITATIONS CONTAINED IN THIS WARRANTY MAY NOT APPLY TO YOU.

8. CHOICE OF LAW.

This limited warranty is governed by the laws of France, without reference to its conflict of law provisions or the U.N. Convention on Contracts for the International Sale of Goods, and shall benefit Thales Navigation, its successors and assigns.

THIS WARRANTY DOES NOT AFFECT THE CUSTOMER'S STATUTORY RIGHTS UNDER APPLICABLE LAWS IN FORCE IN THEIR LOCALITY, NOR THE CUSTOMER'S RIGHTS AGAINST THE DEALER ARISING FROM THEIR

SALES/PURCHASE CONTRACT (such as the guarantees in France for latent defects in accordance with Article 1641 et seq of the French Civil Code).

For further information concerning this limited warranty, please call or write:

Thales Navigation SA - ZAC La Fleuriaye - BP 433 - 44474 Carquefou Cedex - France.

Phone: +33 (0)2 28 09 38 00, Fax: +33 (0)2 28 09 39 39

DECLARATION OF CONFORMITY

We Thales Navigation, Inc.

471 El Camino Real

Santa Clara, CA 95050 USA

Tel: +1 408 615 5100

declare under our sole responsibility that the product
Reference Number 800964-x

Complies with Part 15 of the FCC Rules. Operation is subject to the following two conditions: (1) This device may not cause harmful interference, and (2) this device must accept any interference received, including interference that may cause undesired operation.

THALES

THALES NAVIGATION
Z.A.C. de la Fleuriaye
B.P. 433 - 44474 Carquefou Cedex
FRANCE
Tél. : +33 (0)2 28 09 38 00
Fax : +33 (0)2 28 09 39 99
www.thales-navigation.com

DECLARATION DE CONFORMITE D'UN EQUIPEMENT RADIOELECTRIQUE

Conformity statement
(DIRECTIVE R&TE 1999/5/CE)

Ref : QN 2003-0010

IDENTIFICATION DE L'EQUIPEMENT / *Equipment identification* :

Marque / <i>Brand</i> :	Thales Navigation
Désignation commerciale / <i>Trade name</i> :	Zmax / Zmax
Type / <i>Type</i> :	Récepteur GPS de précision / <i>High precision GPS receiver</i>
Application prévue / <i>Intended use</i> :	Système topographique / <i>Topographical system</i>

Je soussigné, / I, the undersigned

NOM ET QUALITE DU SIGNATAIRE / *Name and status of agent* :

Gérard Juton Responsable Qualité Opération / *Operational Quality Manager*

- Déclare sous son entière responsabilité que le produit décrit ci-dessus est en conformité avec les exigences essentielles applicables de la directive 1999/5/CE / *Declare that this product is compliant with demands of the 1999/5/CE directive* :

Article 3.1 a : (protection de la santé et sécurité des utilisateurs / *Health and safety of users*)
Norme de sécurité électrique appliquée / Electrical safety standard applied : EN 60950 : 2000

Article 3.1b : (exigences de protection en ce qui concerne la compatibilité électromagnétique / *EMC compatibility demand*)
norme CEM appliquée / EMC standard applied : EN 301 489 - 5 et EN 301 489 - 17

Article 3.2 : (utilisation efficace du spectre radioélectrique, de façon à éviter les interférences dommageables / *Efficient use of spectrum, to avoid harmful disturbance*)
norme RADIO appliquée / Radio standard applied : EN 300 440 - 1, EN 300 390 - 1 et EN 300 607 - 1

A cet effet, déclare que toutes les séries d'essais radio ont été effectuées
/ For that purpose, declare that all radio tests were done

Identification de l'organisme notifié / *Identification of the notified organism* :

EMITECH

Adresse / *Address*: 3 rue des Coudriers - ZA de l'Observatoire - CAP 78
78180 MONTIGNY LE BRETONNEUX
FRANCE

Numéro d'identification / *Identification number* : 0536

Date / *Date* : 04 septembre 2003 / *04 september 2003*

Signature / *Signature* :

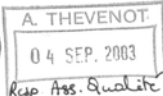

THALES NAVIGATION S.A.
Société Anonyme au Capital de 5 250 000 e
RCS Nantes 321 391 237
Siège social : Z.A.C. de La Fleuriaye - B.P. 433 - 44474 Carquefou Cedex - FRANCE

About This Manual

This manual falls into 11 chapters.

Chapter 1 is an introduction to the various items composing the Z-Max.Net system, including those that may be required but not supplied with the Z-Max.Net. This chapter also gives basic instructions on how to assemble the various parts together and provides a detailed description of the receiver module's front and rear panels. The last section in this chapter introduces the different GNSS antenna mounting configurations depending on whether the Z-Max.Net is used as a base, a pole-mounted or backpack-mounted rover.

Chapter 2 tells you what to do before using Z-Max.Net in the field.

Chapter 3 gives step-by-step procedures to perform RTK surveys using Z-Max.Net. All cases of data links are addressed (radio, GSM, NTRIP, GPRS/IP). This is one of the most important chapters in this manual. RTK surveys with Z-Max.Net are usually conducted using FAST Survey software running on a field terminal, but it can also be performed in standalone mode. Chapter 3 discusses both cases of use.

Chapter 4 gives step-by-step procedures to perform post-processing surveys in static or kinematic. Post-processing surveys with Z-Max.Net are usually conducted from the Z-Max.Net front panel, but it can also be performed using FAST Survey software running on a field terminal. Chapter 4 discusses both cases of use.

Chapter 5 is an introduction to FAST Survey software.

Chapter 6 reviews all the functions that can be accessed via the Z-Max.Net front panel.

Chapter 7 gives information about how Z-Max.Net is powered, how batteries should be charged and stored, etc.

Chapter 8 describes the library of serial commands specific to Z-Max.Net (\$PASH proprietary commands).

Chapter 9 discusses the use of Z-Max.Net with an external CDMA modem for RTK operations. This chapter is more specifically intended for US customers.

Chapter 10 is a collection of the common problems encountered with Z-Max.Net and the way to solve them.

Chapter 11 is the Appendices section of this manual. Various topics are addressed such as RTK parameters, initialization, process, data recording on SD card, ordering information, port pinouts, firmware upgrading procedure, etc.

Table of Contents

1. Introduction	1
What is the Z-Max.Net System?	1
Z-Max.Net Items.....	2
Receiver Module.....	2
GNSS Antenna Module	2
Power Module.....	2
Communication Module	3
V-Module.....	3
UHF Antenna Module	3
Field Terminal.....	4
Cables.....	4
HI Measurement Tool	5
HI Measurement Plate	5
Backpack.....	5
Range Pole RF Adapter	6
Max RF Adapter	6
Void UHF Antenna Module).....	6
Range Pole	6
Hard Shell Case and its Internal Soft Case	7
GNSS Solutions Office Software CD.....	7
FAST Survey Field Software CD	7
User Documentation CD.....	7
SD Memory Card.....	8
Additional Items Required but not Supplied.....	9
For Static Surveys or Base Stations	9
For Kinematic Surveys	10
Specifications	11
Locating the Basic Components.....	14
Z-Max.Net Front Panel.....	14
Bluetooth® Port.....	15
Status LEDs	15
Front Panel Display and Control Keys	16
Power Key.....	16
SD Card Reader and USB.....	16
Z-Max.Net Rear Panel	16
GNSS Antenna Configurations	17
Base.....	17
Pole-Mounted Rover.....	17
Backpack-Mounted Rover	17
Where to Find Information	18
2. Preparing For First-Time Use	19
Charging the Power Module	19
Attaching the Lateral Modules	19
Attaching the GNSS Antenna Module	20
Inserting a Memory Card.....	20

Turning On/Off the System	21
Initializing the System	21
Checking that Z-Max.Net Receives Satellites	22

3. RTK Surveying..... 23

Requirements	23
RTK Base Setup.....	24
Choosing the Installation Site.....	24
Z-Max.Net Unit Setup.....	24
GSM Modem Setup.....	25
PDL Transmitter Setup.....	26
Thales U-Link Transmitter Setup.....	27
RTK Rover Setup	28
Pole-Mounted Rover	29
Backpack-Mounted Rover.....	30
Backpack.....	30
Pole	30
Establishing Bluetooth Communication with Z-Max.Net.....	32
Introduction	32
Powering up the Whole Equipment.....	33
Detecting Bluetooth-Enabled Devices	33
Finding Bluetooth Services	34
Assigning Virtual Ports to Bluetooth	34
Saving Bluetooth Serial Port Settings	35
Defining/Saving Bluetooth Settings for FAST Survey	36
Toggling Bluetooth Between Base and Rover	37
Introduction to Base / Rover Configuration	38
Field Terminal Vs. Front Panel Interface.....	38
Communication Choices	38
Launching FAST Survey.....	39
Saving Base and Rover Settings.....	40
Configuring the RTK Base	41
Setting Communication with the Base	41
Entering Survey System Type & Antenna Height	42
Choosing the Data Link Device, Data Format and Ports	42
Entering the Base Position and ID	43
Setting the Data Link Device	45
Monitoring the Base.....	47
Configuring the RTK Rover.....	48
Preamble	48
Establishing Bluetooth Communication with the RTK Rover.....	51
Settings Common to All Data Link Configurations.....	52
RTK Rover Using a Conventional GSM Data Link.....	53
RTK Rover Using a PDL Radio Data Link.....	54
RTK Rover Using a Thales Radio Data Link.....	55
RTK Rover Using an External Device	56
RTK Rover Using NTRIP Via a GPRS Data Link	57
RTK Rover Using GPRS/IP Via a GPRS Data Link	60
Checking that the RTK Rover Calculates Fixed Solutions	62
Running an RTK Survey	63
Logging RTK Points	64

Logging RTK Points in Continuous Mode	65
Staking out RTK Points	66
Localization (or Calibration, or Local Grid).....	68
Running an RTK Survey from the Front Panel.....	71
AUTO POINT RTK Survey	71
TRAJECTORY RTK Survey.....	74
MANUAL RTK Surveys	76
Downloading RTK Results to GNSS Solutions.....	79
4. Post-processing Surveying	81
Reminder on Post-Processing Surveying Techniques.....	81
Static	81
“Stop & Go” Kinematic	82
Continuous Kinematic	83
Kinematic Initialization Methods	84
Running a Static Survey	85
Introduction to Static Surveying	85
Network Design	85
Observation Plan.....	88
Static Occupation Times.....	94
Base and Rover Setup	95
Starting Data Collection.....	98
End of Data Collection	98
Running a Kinematic Survey	99
Stop & Go Kinematic	99
Continuous Kinematic	100
Base Setup.....	101
Pole-Mounted Rover.....	101
Backpack-Mounted Rover.....	102
Getting the Z-Max.Net Unit Started in Kinematic	104
Starting Data Collection.....	106
End of Data Collection	107
Running a Post-processing Survey Using FAST Survey	108
Static Mode	108
Kinematic Mode	108
File Management	109
Downloading Field Data to your PC.....	110
Using A Local SD Card Reader.....	110
Using Serial Connection to Z-Max.Net	111
Post-Processing Field Data	112
5. FAST Survey Software.....	115
Introduction	115
MENU Screen	115
File tab	115
Equip tab.....	117
Surv tab.....	118
COGO tab.....	119
Road tab.....	120
MAP Screen	121

Using the Internal GPS Antenna.....	122
-------------------------------------	-----

6. Operating Z-Max.Net from its Front Panel..... 123

Introduction.....	123
Control Keys.....	123
Display Mode	124
Edit Mode	124
Using Control Keys	125
Disabling Beep.....	125
Waking Up the Display	126
Automatic Data Recording	126
Saving Operating Parameters	126
Front Panel Interface Function Diagram	127
SYSINFO Menu (System Information)	128
SURVEY:... Menu (Survey Parameters and Status)	128
SURVEY:STATIC	129
SURVEY: KINEMATIC	131
SURVEY: RTK BASE.....	132
SURVEY:RTK ROVER	134
SURVCONF Menu	140
SURVCONF: STATIC.....	140
SURVCONF: KINEMATIC	141
SURVCONF:RTK BASE	142
SURVCONF:RTK ROVER	144
SESSIONS (Session Control).....	147
SETTINGS	148
COM OPTN	150
Thales Radio.....	150
PDL Radio.....	153
GSM Rover.....	156
GSM Base.....	159
Warning Messages	161

7. Power Management..... 165

Power Module Types	165
Battery Time Remaining.....	165
External Power.....	166
Charging	166
Conditioning.....	167
Disposition	168
Battery Life.....	169
Power Drain	169
Storage	169
After Storage	170
Li-Ion Internal Battery Specifications	170

8. \$PASH Proprietary Commands.....171

Applying Serials Commands to Z-Max.Net	171
From the office Computer.....	171
From the Field Terminal.....	171
Command Summary Table	172
Set Commands	173
DIP	173
MDM,DAL	174
MDM,INI.....	175
MDM,OFF	175
MDM,ON.....	176
MDM,PAR.....	177
NME,MSG.....	179
NTR,LOD	181
NTR,MTP	181
NTR,PAR.....	182
PRT	182
RDP,CHN	183
RDP,FRM.....	184
RDP,LOD	184
RDP,LSP	185
RDP,OFF	185
RDP,ON.....	186
RDP,PRG	186
RDP,SST.....	187
RDP,TYP	187
REC.....	188
RT3,BAN.....	188
RT3,BAS.....	189
RT3,OFF	189
RT3,POS	190
RT3,STI	191
RT3,TYP.....	191
RTC,WAT.....	192
SBA.....	193
SBA,AUT	193
SBA,MAN	195
Query Commands	196
BAT	196
BEEP.....	197
MDM	197
MDM,LVL.....	199
MDP.....	199
NTR	200
NTR,TBL.....	201
RDP.....	202
RDP,CHT	204
RDP,FRM.....	205
RDP,TYP	206
RDP,USR	207
RT3	210
WARN	211
WARN,MDM	213

9. Using An External CDMA Modem.....	215
Introduction.....	215
Activating the Modem	216
Installing the Rover Modem	219
Configuring the modem.....	219
Configuring the Z-Max.Net Unit.....	222
Hang-up.....	223
Troubleshooting	224
10. Troubleshooting.....	225
Receiver is Not Tracking Satellites	225
Receiver is Not Recording Data.....	227
Base Radio is Not Transmitting Data	229
Rover Radio is Not Receiving Data from Base	233
Rover is Not Computing a Position.....	237
Rover is Computing Positions with High Uncertainties.....	240
11. Appendices	245
RTK Parameters.....	245
Data Formats	245
Positioning Modes.....	245
Logging Modes.....	248
Position Output Rate	249
Base Station Position.....	249
Antenna Reduction	250
Initialization Process	251
General Considerations	251
On The Fly (OTF)	252
By performing a static survey	254
3. On a known point	254
Data Recording on SD Card	256
Setting the Data Recording Interval	256
Data File Logged on SD Card	257
File Naming Convention	258
Almanac file Naming Convention.....	259
Ordering Information	260
Port Pinouts.....	262
Power Port	262
Serial Ports	262
USB Port.....	264
Uploading New Firmware.....	265
Step 1 - Acquire the New Firmware.....	265
Step 2 - Insert the SD Card into the Receiver	265
Step 3 - Connect Communication and Power Modules	266
Step 4 - Initiate Firmware Upload	266
Step 5 - Monitor the Upgrade.....	267
Step 6 - Verify the New Version	267
Firmware Options.....	268

Introduction.....	268
Firmware Options Detailed List	269
Most Commonly Accessed User Parameters and Their Default Values	272

1. Introduction

What is the Z-Max.Net System?



The Z-Max.Net system is designed to meet the needs and requirements of land surveyors involved in demanding applications including topography, construction, mining and oil exploration. The Z-Max.Net system is perfect for any surveying application that requires both high precision and high productivity.

The Z-Max.Net Surveying System is based on a modular mechanical design. Each module is designed to attach easily, quickly, and securely. In some configurations, the Z-Max.Net system is completely cableless. Where cables are required, they are designed to be durable and easy to use.

Survey setup is easy, and you only have to use the modules that you need. Modules are interchangeable, so different systems can be put together using the same core parts.

With its lightweight, durable, magnesium housing the rover system is light enough to be carried around all day.

Battery issues won't slow you down either. The Z-Max.Net power module containing Lithium Ion battery cells can power the receiver for over 13 hours.

The Z-Max.Net also includes the latest in wireless technology to eliminate cables when transferring data between devices. You can communicate with the receiver wirelessly with a small field terminal and you can even wirelessly download data to the PC!

In Z-Max.Net, ALL functions from the first version of Z-Max have been maintained with the following additional features, making Z-Max.Net the most flexible RTK system available on the market:

- GPRS capability allowing Z-Max.Net to acquire RTK correction data through NTRIP (*Networked Transport of RTCM via Internet Protocol*) or from a base that can be accessed via a fixed IP address (GPRS/IP mode).
GPRS is based on the packet-switched data mode that allows communication costs to be significantly reduced compared to GSM.
- Additional RTK correction data formats such as RTCM3.0, FKP.

Z-Max.Net Items

Receiver Module



The Receiver module contains the GNSS receiver, the memory card, front panel display, external serial ports, USB port, and power port.

The Receiver module also contains the internal Bluetooth module that allows the receiver to wirelessly communicate with external devices. Virtually all the modules will attach in some way to the Receiver module.

GNSS Antenna Module



The Max-Trac GNSS antenna module contains the GNSS antenna which allows the Z-Max.Net receiver to track signals from the GPS satellites. This geodetic quality antenna will accurately and consistently track satellites above the horizon and provide good multipath rejection for signals reflecting from intermediate surfaces such as the ground.

The GNSS antenna module is designed to either connect directly to the Receiver module, or to the top of the UHF antenna module if the Z-Max.Net is intended for real-time operation.

The GNSS antenna module connects without cables.

Power Module



The Power module is the primary power source for the Z-Max.Net. Inside the Power module are rechargeable lithium ion battery cells. The Z-Max.Net comes with two different power capacities:

- The Max-Run power module has a capacity of 8.8 amp-hours and should power the Z-Max.Net for over 13 hours in typical user scenarios.
- The Max-Lite power module is a lighter configuration that provides 4.4 amp-hours of power. The Max-Lite power module is capable of powering the receiver for over 6 hours in typical user scenarios.

The Power module also contains a battery charger and other "smart" functionality to provide usage information, monitor the battery while it's recharging, and advise the user about battery maintenance. For more information about this module, see *Power Management on page 165*.

Communication Module

The Communication module contains the data link(s) for transmitting or receiving data during DGPS and RTK applications. The Communication module can include one or a combination of the following options:

- Thales U-Link radio receiver
- Pacific Crest PDL radio receiver
- Cellular Modem

Depending upon the option you have selected, the Communication module may have both a UHF radio and a cellular modem, a UHF radio by itself, or a cellular modem by itself. See also *page 12*.

V-Module

The V-module has exactly the same aspect (shape and connectors) as the communication module (see above) except that the module is empty. The V-module is used to seal the Z-Max.Net unit in such configurations as:

- RTK base with external UHF radio transmitter
- Any base or rover configuration in post-processing mode.

UHF Antenna Module

The Vortex UHF antenna module is the UHF antenna for all UHF Communication modules. The UHF antenna module is connected between the GNSS antenna module and the Receiver module and routes the radio signal to the radio inside the Communication module.



Field Terminal

The field terminal is used to interface with and control the Z-Max.Net in the field. It is primarily used with the rover receiver during kinematic, RTK and code-phase differential surveys.

Most users will use a field terminal and graphical application software (FAST Survey) to execute intensive real-time operations such as real-time navigation (stake-out). Two field terminals can be used with the Z-Max.Net:

- Thales MobileMapper CE
- Juniper Allegro CX

Each of these two devices is designed to operate with Bluetooth short range wireless technology, so no cable is required between the field terminal and the receiver. The operator can either communicate with the receiver from up to 10 meters away without cables, or may choose to use a cable. Each of these devices has its own field bracket for easy fastening onto the pole.



Cables

The USB cable is used to connect the Z-Max.Net unit to an office computer.

The serial data cable is used to allow the user to control the Z-Max.Net unit from the field terminal via a serial RS232 line.

The GPS-RF and UHF-RF cables connect the range pole RF adapter to the max-RF adapter. These are identical cables except for color coding. The GPS-RF cable is coded black and the UHF-RF cable grey. The GPS-RF cable is always required when the Z-Max.Net unit is carried in a backpack. The UHF-RF cable is required in the same carrying configuration for an RTK rover using a UHF radio data link.



HI Measurement Tool



The HI measurement tool is used to provide a convenient location on the Z-Max.Net system where the slant height of the antenna above the mark can be consistently and accurately measured. It attaches to the Z-Max.Net system between the bottom of the receiver module and the tribrach. The HI measurement tool is only used when the Z-Max.Net system is either a static receiver or a kinematic base station.

HI Measurement Plate



An accurate measurement of the height of the antenna above the survey mark is very important. However, when the Z-Max.Net system is attached to a tripod, there is not enough clearance to measure the antenna height from the survey mark to the GPS antenna.

The HI measurement plate is used to provide a convenient location on the Z-Max.Net System where the slant height of the antenna above the mark can be consistently and accurately measured. It attaches to the Z-Max.Net system between the bottom of the GPS receiver module and the tribrach.

Backpack



The backpack provides a comfortable way for a person to carry the Z-Max.Net unit on the back.

Range Pole RF Adapter

When the Z-Max.Net system is operating as a backpack-mounted kinematic rover, a cable is required to connect the Receiver module in the backpack to the GNSS antenna module on the survey pole. The Range Pole RF adapter is the module where the cable physically connects to the survey pole and the GNSS antenna module. The Range Pole RF adapter connects between the survey pole and the GNSS antenna module.



Max RF Adapter

When the Z-Max.Net System is operating as a backpack-mounted kinematic rover, a cable is required to connect the Receiver module in the backpack to the GNSS antenna module on the survey pole. The Max-RF adapter is the module where the cable physically connects to the Receiver module. The Max-RF adapter connects to the top of the Receiver module in the same receptacle where the GNSS antenna module connects during a static survey.



Void UHF Antenna Module)

The void UHF antenna module is used when the Z-Max.Net system is functioning as a kinematic post-processed rover. The void UHF antenna module is used to raise the GNSS antenna module high enough on the survey pole so that the antenna's view to the satellites is not blocked by the user. The void UHF antenna module connects between the GNSS antenna module and the receiver module when using a pole-mounted system, or between the GNSS antenna module and the Range Pole RF adapter when using a backpack-mounted system. The pole adapter is the same size and shape as the UHF antenna module.



Range Pole

The range pole is a fixed-height survey pole.



Open hard shell case showing Z-Max.Net in its soft case:



Above:
Soft case removed from hard shell case

Hard Shell Case and its Internal Soft Case

The hard shell case is recommended for shipping equipment through package delivery companies or checking as baggage on an airline. The hard-shell case can also protect the equipment when the gear is being transported in conditions where rough impacts are common, like the back of a truck.

The soft case is designed to fit snugly into the hard-shell case. It's a padded case with semi-rigid compartments for each Z-Max.Net module. There is additional storage for miscellaneous items.

The compartments in the soft-case are adjustable to accommodate different collections of modules and peripheral hardware. All components can be housed in the soft case with the exception of the tripod and the rover pole, that is optional with the system.

GNSS Solutions Office Software CD

This CD allows you to install GNSS Solutions and its documentation to your office PC. The GNSS Solutions software provides the tools required to download data from the field terminal (RTK data) or the Z-Max.Net unit (raw data stored on the memory card).

Missing Picture

FAST Survey Field Software CD

This CD allows you to install FAST Survey from the CD reader of your office computer to the field terminal you are using. Before starting installation, make sure you select the installation file corresponding to your field terminal.

Missing Picture

User Documentation CD

This CD includes the Z-Max.Net Getting Started Guide and the present Reference Manual in PDF format..

Missing Picture



SD Memory Card

All raw data recording in the Z-Max.Net is done on an SD (Secure Digital) memory card. The SD memory card is a highly-sophisticated memory device about the size of a postage stamp. The SD card slot is located inside the small panel door on the front panel of the receiver. The SD card is used to record data and load new receiver firmware. The receiver comes with a 64 MB SD card as standard, but optionally, SD cards with larger capacities are available. Weighing less than two grams, the SD card offers a powerful combination of small size, high storage capacity, and fast data transfer.

Additional Items Required but not Supplied

For Static Surveys or Base Stations

These items allow you to firmly position the Z-Max system over the survey point or station site (see opposite) at a measurable height from the ground.

These items (tripod, tribrach and tribrach adapter) are illustrated below.

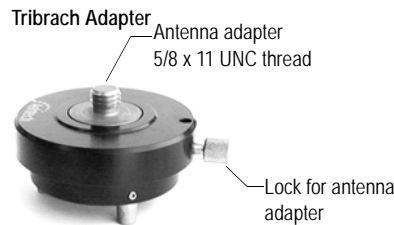
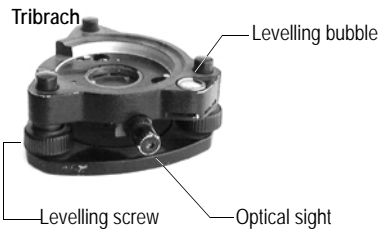

An option to the tripod, tribrach and tribrach adapter combination is the fixed-height GPS tripod (see below).



For Kinematic Surveys

An option for mounting the Z-Max rover when operating in kinematic mode is a range pole (see below).



Specifications

Parameter	Specification
GPS	Static, Rapid Static - 24 parallel channels all-in-view - L1 C/A code and carrier - L1/L2 P-code, full wavelength carrier - Z-Tracking - Multipath mitigation - Integrated real-time WAAS/EGNOS - Update rate: 10 Hz - Protocol: NMEA0183
Accuracy (1-2)	Static, Rapid Static - Horizontal 0.005 m + 0.5 ppm (0.016 ft + 0.5 ppm) - Vertical 0.010 m + 0.5 ppm (0.033 ft + 0.5 ppm) Post-processed Kinematic - Horizontal 0.010m + 1.0 ppm (0.033 ft + 1.0 ppm) - Vertical 0.020 m + 1.0 ppm (0.065 ft + 1.0 ppm)
Real-Time Performance (1-2)	SBAS (WAAS/EGNOS) (rms) - Horizontal: < 3 m (10 ft) Real-Time DGPS position < 0.8 m (2.62 ft) Real-Time Kinematic Position (fine mode) - Horizontal 0.010m + 1.0 ppm (0.033 ft + 1.0 ppm) - Vertical 0.020 m + 1.0 ppm (0.065 ft + 1.0 ppm) Instant-RTK Initialization - 99.9% reliability - Typical 2-second initialization for baselines < 20 km
Data Logging	Recording Interval - 0.1-999 seconds
Physical	Size - Unit: 26.9 x 12.5 x 14 cm (10.6 x 4.9 x 5.5 in) - Antenna (Dia. x H): 19 x 10.1 cm (7.5 x 4.0 in) Weight Receiver module: 1.371 kg (3.02 lb) Antenna module: 0.64 kg (1.17 lb) Power module: 0.52 kg (0.96 lb) Front Panel - Eight-character alphanumeric LED display - 4 tri-color LEDs - 5-key keyboard

Parameter	Specification
Physical (cont'd)	<p>Memory</p> <ul style="list-style-type: none"> - 48 hours of 1-sec raw GPS data with 64 MB Secure Digital - 128-MB SD card available <p>I/O Interface</p> <ul style="list-style-type: none"> - RS232, RS232/422, USB, Bluetooth
Environmental	<p>Receiver</p> <ul style="list-style-type: none"> - Operating temperature: -30° to +55°C (-22° to +131°F) - Storage temperature: -40° to +85°C (-40° to +185°F) - Meets IP54 for moisture - Shock: 1.5 m (4.92 ft) pole drop - Vibration: MIL-STD-810F Method 514.4 (I-3.1.1, I-3.4.8, I-3.4.9)
Power	<ul style="list-style-type: none"> - Max-Run battery life time > 14 hrs. - 10-28 V DC input - Regulated 12-V DC output on serial ports
Field Terminal Language Support	<p>English, French, German, Spanish</p>
System Components	<p>Standard</p> <ul style="list-style-type: none"> - Z-Max.Net GPS receiver - GPS antenna - Power module, charger included - System bag - Hard-shell shipping case <p>Communication modules (3)</p> <ul style="list-style-type: none"> - Thales UHF - Pacific Crest UHF - GSM/GPRS Tri-band - GSM/GPRS Dual-band (US) - GSM/GPRS EU + Thales UHF - GSM/GPRS EU + PacCrest UHF - GSM/GPRS US + Thales UHF - GSM/GPRS US + PacCrest UHF <p>Field terminal kit with FAST Survey (3)</p> <ul style="list-style-type: none"> - Thales MobileMapper CE - Juniper Allegro CX <p>Other (3)</p> <ul style="list-style-type: none"> - Thales UHF transmitter kit - Pacific Crest transmitter kit - RTK rover backpack kit - Rechargeable battery kit

Parameter	Specification
GNSS Solutions Office Software	<p>Key Functions</p> <ul style="list-style-type: none"> - Integrated transformation and grid system computations allow for processing, adjusting, reporting and exporting point positions in user-selected or user-defined systems - Pre-defined datums along with user-defined capabilities using the 7-parameter method of computing and applying datum transformation parameters - Survey mission planning - Automatic vector processing - Least-squares network adjustment - Data analysis and quality control tools - Coordinate transformations - Reporting - Exporting - Geoid 03 - English, Spanish, French, German language support <p>System Requirements</p> <ul style="list-style-type: none"> - Windows 2000 / XP - Pentium® 133 or higher - 32 MB RAM - 90 MB disk space required for installation
FAST Survey Field Software	<p>Key functions</p> <ul style="list-style-type: none"> - Map view - Geodetic geometry: intersection, azimuth/ distance, offsetting, polyline, curve, area - Z-Max.Net GPS support : configuration, monitoring and control - Coordinate system support: predefined grid systems, predefined datums, projections, Geoids, local grid - Data import/export: DXF, SHP, RW5, LandXML, ... - Survey utilities: calculator, RW5 file viewing - Compatibility with optical surveying instruments - Road construction <p>Supported Hardware</p> <ul style="list-style-type: none"> - Thales MobileMapper CE - Juniper Allegro CX

(1) Performance values assume minimum of five satellites, following the procedures recommended in the product manual. High-multipath areas, high PDOP values and periods of severe atmospheric conditions may degrade performance.

(2) Accuracy and TFF specifications based on tests conducted in Nantes, France, and Moscow. Tests in different locations under different conditions may produce different results.

(3) System composition varies depending on the chosen configuration

Locating the Basic Components

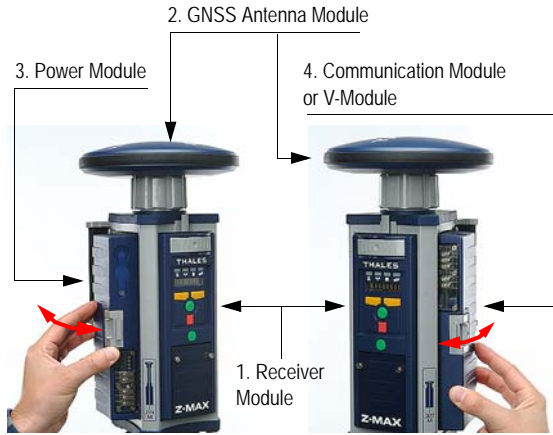

As you are facing the front panel of the GPS receiver module, the power module attaches to the left-hand side of the receiver module and the communication module (or V-module) to the right-hand side.

Z-Max.Net Front Panel

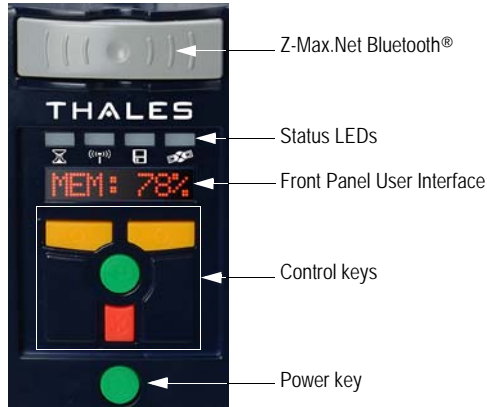

Bluetooth® Port

This device allows you to communicate with the Z-Max.Net through a Bluetooth wireless connection. This port is identified as “port C” on the Z-Max.Net.

Status LEDs

From left to right, the LEDs are:



- **RTK Solution.** This LED is only operational when the receiver is configured as an RTK rover.

Color	Meaning
Off	Not a RTK rover
Blinking green	Fixed solution
Blinking orange	Float solution
Blinking red	No RTK solution



- **Communication.** This LED indicates when real-time data transmitted from a base has been received by the rover.

Color	Meaning
Off	No data link has been configured
Blinking green	Base: Transmits data Rover: Base data received and used
Blinking red	Base: Irrelevant Rover: Base data received but not used
Not blinking	Base: No data transmitted Rover: No base data received



- **Data Log.** This LED shows the data logging status.

Color	Meaning
Off	No data logging in progress
Blinking green	Data logging in progress. Blinks at the frequency of the recording interval setting (20 seconds by default).
Red	Unable to log data (memory full)



- **Satellite/Power.** After power up, this LED will continue to blink red once every 1-2 seconds to indicate that the unit is powered on. Between each red blink, the LED will also blink green once for each satellite that the receiver is tracking.

Front Panel Display and Control Keys

See all details in *Operating Z-Max.Net from its Front Panel* on page 123.

Power Key

This key is used to power up, power down or initialize the unit (see page 21).



SD Card Reader and USB

Below the four control keys is a small door fastened by two thumbscrews. Unscrew the attaching screws and open the door to reveal the SD Card slot and the USB port.

The SD card slot holds the SD card that serves as the receiver's data storage memory. All data recorded by the unit is stored on the SD card. **Warning! Use exclusively SD cards sold by Thales.**

The USB port is one of the external ports available for connecting to a computer. The USB port is a type-B connector.



Z-Max.Net Rear Panel



For connector pinout, see *Port Pinouts* on page 262.

GNSS Antenna Configurations

In all cases of use, the GNSS antenna module must be connected to the receiver module. But there are three different ways of doing this, as explained below.

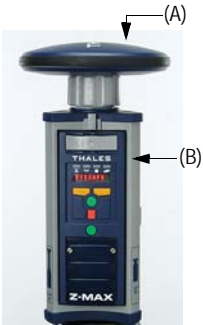

Base

The GNSS antenna module (A) is directly attached to the receiver module (B).



Pole-Mounted Rover

The GNSS antenna module (A) is attached to the receiver module (B) via a UHF antenna module or a Void UHF antenna module (C). →

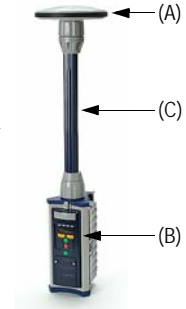

Backpack-Mounted Rover

The GNSS antenna module (A) is attached to the receiver module (B) via a UHF antenna module or Void UHF antenna module (C), a range pole adapter (D), a dual RF cable (E) and a Max-RF adapter (F).

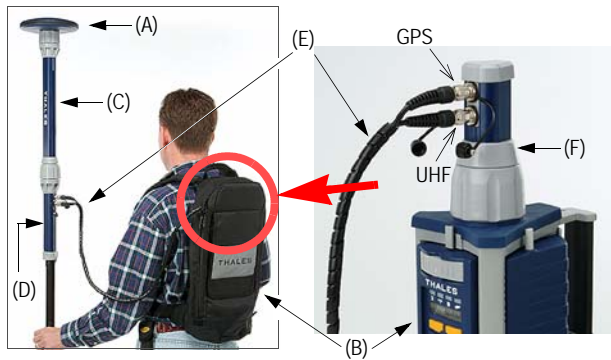

Where to Find Information

This manual is designed to guide you through the RTK and Post-processing surveying methods as well as provide general reference. You can find additional information in the following documents:

Z-Max.Net Getting Started Guide: This manual describes the basic procedures to start using Z-Max.Net in RTK and Post-processing surveying. It also briefly explains how to download your field data to the office software and how to view and/or process this data.

GNSS Solutions Reference Manual: This manual provides detailed instructions for post-processing and presenting the data collected by Z-Max.Net.

Z-Family Technical Reference Manual: This manual provides a detailed description of all the \$PASH commands that can be applied to the Thales Z-Family of GNSS receivers, including Z-Max.Net. Note that all the \$PASH commands specific to Z-Max.Net are described in this manual. See *\$PASH Proprietary Commands on page 171*.

Thales Navigation FTP site: Many useful documents relating to the Z-Max.Net are available at the following FTP site: [ftp://ftp.thalesnavigation.com/Reference Manuals/Z-Max](ftp://ftp.thalesnavigation.com/Reference%20Manuals/Z-Max)

2. Preparing For First-Time Use

Charging the Power Module

To charge the power module:



- Plug in your charger and connect the power module to the charger as shown opposite.
- Charge **for a minimum of five hours** or preferably overnight (even if the charger indicates that the battery is full).
- Verify that the battery is fully charged by pressing the button on the back side of the power module. The four LEDs should light up green.



Use of non-Thales power supplies for charging the power module is not recommended.

The power module contains rechargeable lithium-ion battery cells and “smart” charging circuitry. Recharging the power module is done using the AC/DC power supply, included with the system.

This power supply can also be used to provide power directly to the Z-Max.Net through an external connector. The charger is designed to work with a 110-240 VAC power source and delivers 12 V DC of input voltage with at least 4-A current capability to the power module.

For more information on the characteristics and management of the power module, see *Power Management* on page 165.

Attaching the Lateral Modules



Whatever the type of module you are attaching to the receiver module, i.e. a power module on the left, or a communication or V-module on the right, do the following:

- Insert the small ledge of the module into the rear of the housing first as shown opposite (left and right). This will correctly align the module.





Please take all precautions to keep connector pins clean and avoid touching them.

- Using the ledge like a hinge, start swinging the module. To make sure the module is correctly positioned vertically, take care to align the protruding edges, on either side of the connector pins, with the grooves in the receiver module casting. Then swing the module closed until the latch on the module clicks into place.
- Make sure the module is well seated and the latch on the edge of the module clicks shut.

Attaching the GNSS Antenna Module

The base of the GNSS antenna module is circular except for a flattened area. The top of the receiver module, UHF antenna module or Void UHF antenna module is keyed so there is only one way the GNSS antenna module can be inserted.



- Make sure the base of the GNSS antenna module is oriented so that the flattened area is lined up with the flattened area of the receptacle.
- Once aligned, insert the GNSS antenna module into the antenna receptacle. The module should push easily into place.
- Once in place, twist the threaded collar on the GNSS antenna module until the antenna is securely locked in place.

Inserting a Memory Card

A memory card is required if you want to run a post-processing survey or more generally, when you want to log raw data with your Z-Max.Net.

To install the SD Memory Card into the reader:

- Orient it so that the chamfered corner of the card is oriented downwards, as shown opposite.
- Gently push the card into the reader until you feel a soft “click”. The click indicates that the card is properly seated. A correctly inserted SD card should not move once you have removed your hand from the card.



Use exclusively SD cards sold by Thales!



It is important to power off the receiver using the Power key on the Front Panel *before* removing the SD card.

Turning On/Off the System

- Power on the system by pressing the Power button on the receiver front panel for about 2 seconds (until a beep is emitted) and then release the Power button.
The SV/Power LED should begin to blink red once per second to indicate that the receiver is powered up.
- To turn off the system, just press and hold the power key for two seconds. The receiver will generate a beep every second, a “shutdown” message will be displayed, and the receiver will then power down.

Initializing the System

Initializing the system is recommended the first time you use your system to:

- Clear the internal memory
- Reset the user settings to their default values
- Clear ephemeris and almanac information in memory
- Re-format the SD card. Note that initialization should also be performed every time you prepare your SD card for a new survey project. It’s always better to delete files from the SD Card by running an initialization sequence rather than using any other method.



Initializing the system is also appropriate any time the Z-Max.Net does not work as expected.

To initialize the system from the Power button, assuming the system is off, do the following:

- Press the Power button for at least 5 seconds.
The display will show “re-init”, indicating that the receiver is in the initialization process.
The initialization process will take several minutes depending on the size of the SD card. The front panel will continue to display “re-init” until the process is complete.
When complete, the receiver will be powered on and in the normal state with the front panel displaying “SYSINFO” and the SD card ready to use.



Please go outside after initialization and make sure your system has a clear view of the sky in all directions.

Checking that Z-Max.Net Receives Satellites

If the GPS antenna has a reasonably good view to the sky, within a few minutes, the receiver should begin to track satellites. This is indicated by the SV/Power LED:

1. It should blink red once per second to indicate that power is on, and blink green several times between each red blink.
2. It will blink once for each satellite that is being tracked. In normal conditions of reception, the system should receive about eight satellites on average.

3. RTK Surveying Requirements

Key information is provided below.



When the base setup is under your responsibility, make sure the base is sited in a clear area giving the best possible view of the sky!

When this is possible, avoid trees, buildings or any high obstacles in the vicinity of the base.

Having a clear view of the sky will allow the base to collect data from a maximum of visible satellites, which is highly recommended to perform a successful, accurate and fast survey.

1. Two units are needed: one (the base) is operated on an accurately known position while the other (the rover) is used in the working area.
2. A data link must be established from the base to the rover. This data link can be implemented in three different ways:
 - UHF radio
 - Cellular modem (GSM, GPRS)
 - Other external device
3. Depending on the chosen data link, the base will be either:
 - A "real" base system (with UHF radio, GSM, or other external device)
 - Or a "virtual" base system that delivers its data via a cellular modem (GPRS).

The main Z-Max.Net RTK system configurations are illustrated below:

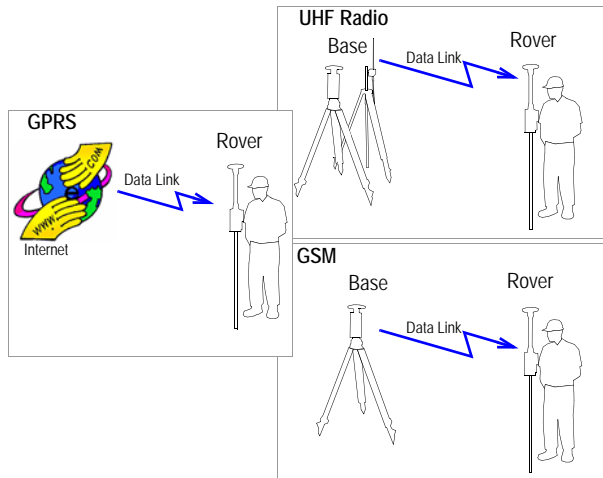

4. Two different rover setups can be used, backpack or range pole, yet operated similarly.
5. RTK is easier to operate using a field terminal running FAST Survey. RTK can also be operated from the receiver front panel display.
6. Whatever the base used ("real" or "virtual"), its distance to the rover, called "baseline" (up to 50 km or 30 miles), must roughly be known to make sure RTK results will achieve the expected level of accuracy.

RTK Base Setup

The RTK base setup described in this section uses a conventional tripod. To configure the base, a Bluetooth-enabled field terminal (MobileMapper CE) run by FAST Survey is used.



Choosing the Installation Site

The installation site should offer the best possible GPS reception conditions. The GNSS antenna should have a clear view of the sky in all directions. There should be no, or a minimum of satellite obstructions in the vicinity.

Z-Max.Net Unit Setup

Whatever the data link you intend to use, the Z-Max.Net unit should be prepared and installed as instructed below. The additional setup steps specific to the data link used are addressed in the next sections.

1. Connect the system components (power module, GNSS antenna and communication module) as explained on page 19.

If you are using an external UHF radio transmitter for the data link, you do not need a communication module. Instead, a V-module can be attached to the right side of the receiver module to seal the unit.

If you are using a GSM modem for the data link, attach the adequate clip-on communication module to the receiver module.

2. Center and level the tripod over the ground mark.

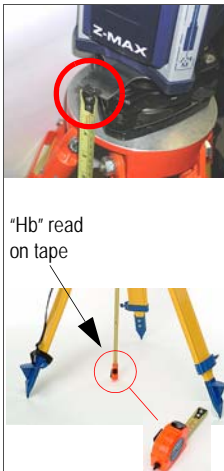

3. Insert the brass tribrach adapter through the hole in the HI measurement plate and screw the adapter/plate into the 5/8" threaded receptacle in the bottom of the Z-Max.Net receiver module.
4. Carefully place the Z-Max.Net assembly into the tribrach mounted on the tripod over the point.
5. Use the tape to measure from the center of the point on the ground to the measurement point of the Z-Max.Net (see *Hb* opposite). Later on, you will have to enter the value read on the tape (see point 2. on page 42).
6. If you wish to power up the Z-Max.Net unit from an external power source, connect the power cable supplied (P/N 730477) to the Z-Max.Net power input (marked "PWR") located on the rear panel. Connect the other end of the cable to the power source using the alligator clips.



GSM Modem Setup

There are no additional steps required if the GSM modem you wish to use is in the communication module you have attached earlier to the receiver module (see *Z-Max.Net Unit Setup* on page 24).

If you are using an external modem at the base for CDMA or GPRS operation, please refer to *Using An External CDMA Modem* on page 215.

PDL Transmitter Setup

If you are using a 2- or 35-W PDL UHF radio, follow these instructions:

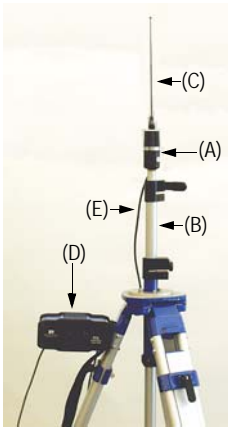

1. Install the tripod for the UHF radio transmitter a couple of meters away from the Z-Max.Net tripod. The distance between the two tripods is limited by the length of the data/power cable connecting the Z-Max.Net receiver to the radio.
2. Attach the antenna mount (A) at the top of a telescopic pole (B) (as shown opposite) or a tripod
3. Screw the radio antenna (C) to the antenna mount (A)
4. Locate the mounting flange at the top portion of one of the tripod legs and hook the radio (D) in place as shown opposite using the built-in mounting bracket
5. Connect the antenna cable supplied (E) between the antenna and the ANTENNA connector on the radio
6. Connect the radio unit to the Z-Max.Net unit by plugging the 5-pin end of the cable into the radio (to DATA/PWR connector for 25-W version; to data/power connector located under the LED display for the 2-W version) and the 7-pin end of the cable to port B on the Z-Max.Net unit.
7. Connect the battery end of the Y-cable, fitted with alligator clips, to the battery. A large battery is needed to transmit at 35 W.

The diagram below summarizes the different connections described previously for a 35-W transmitter.

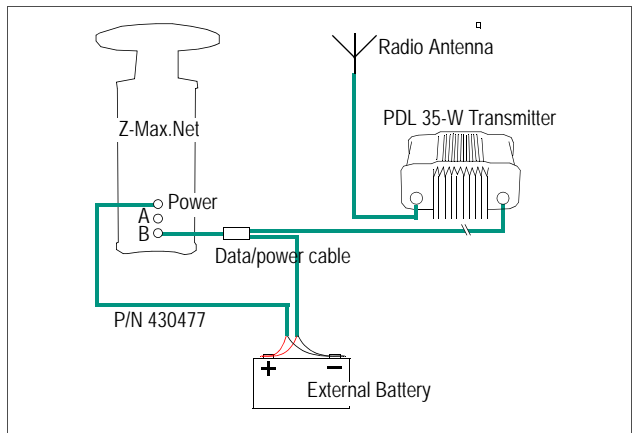

Thales U-Link Transmitter Setup

If you are using a 0.5- or 4-W Thales UHF radio, follow these instructions:

1. Install the tripod for the UHF radio transmitter a few meters away from the Z-Max.Net tripod. The distance between the two tripods is limited by the length (10 meters) of the data/power cable connecting the Z-Max.Net receiver to the radio (see point 4 below).
2. Screw the radio antenna (A) to the antenna connector on the U-Link radio (B).
3. Hook the flange on the radio into the mounting bracket (C), and attach the mounting bracket to the telescoping survey pole (D).
4. Connect the Y-shaped data/power cable (P/N 730476) between 7-pin connector port B on the Z-Max.Net and the 15-pin data/power port on the U-Link radio (E).
5. Connect the free end of the data/power cable to the battery
6. Raise the UHF radio and its antenna together as high as possible to maximize transmission distance.

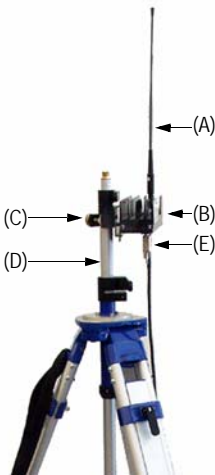

The diagram below summarizes the different connections described previously.



Use exclusively a 12-V DC battery to power the U-Link transmitter. Using a 24-V DC battery is only allowed for powering the Z-Max.Net.

Reminder:

Z-Max.Net Power

Input Range:

10-28 V DC

U-Link Transmitter

Power Input Range:

9-15 V DC

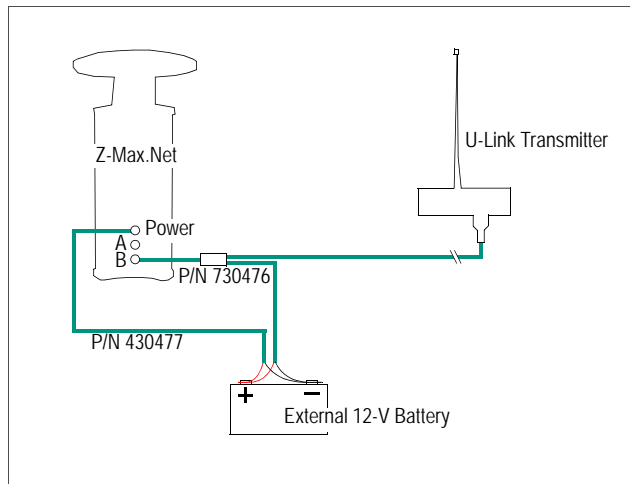

RTK Rover Setup

The rover system may be mounted on a pole or placed in a backpack:

- In the pole-mounted configuration, all the components are pole-mounted, thus eliminating the need for cables or any physical connection between the user and the system.
- In the backpack rover system, the Z-Max.Net unit (receiver module, power module and communication module) is mounted in a backpack. The GPS antenna, and UHF antenna if used, are mounted together on the survey range pole and are connected by cable to the system in the backpack. Compared to the pole-mounted system, the backpack rover system uses additional components to connect the antenna(s) to the system.

The table below lists all the components that are part of the system depending on the data link used and the carrying method.

Components	Pole-Mounted					Backpack				
	GSM	PDL	THL	NTRIP	GPRS/IP	GSM	PDL	THL	NTRIP	GPRS/IP
GNSS receiver module	●	●	●	●	●	●	●	●	●	●
GNSS antenna module	●	●	●	●	●	●	●	●	●	●
Power module	●	●	●	●	●	●	●	●	●	●
Communication module (+ type)*	● GSM	● PDL	● THL	● GSM	● GSM	● GSM	● PDL	● THL	● GSM	● GSM
UHF antenna module		●	●				●	●		
Void UHF antenna module	●			●	●	●			●	●
Range pole	●	●	●	●	●	●	●	●	●	●
Range pole RF adapter						●	●	●	●	●
Max RF adapter						●	●	●	●	●
Backpack						●	●	●	●	●
GPS-RF cable						●	●	●	●	●
UHF-RF cable							●	●		

* Communication modules can contain two types of devices (e.g. GSM+PDL, GSM+THL, etc.). For more information, see your local dealer.

Pole-Mounted Rover





1. Connect the system components (power module, GNSS and UHF antenna modules, communication module) as explained on page 19 taking into account the information provided in the table on page 28 to determine which components should be used.
2. Mount the Z-Max.Net assembly on the survey pole:
 - Remove the brass adapter from the top of the pole and attach it to the base of the Z-Max.Net assembly.
 - Seat the Z-Max.Net onto the pole.

If no adapter is available, just thread the pole directly on to the base of the receiver.
3. Determine the height of the range pole (see *Hr* opposite). If you are using a standard pole, this height is given by the pole manufacturer so you don't need to measure it. You will later have to remember this height when setting the rover (see point 2. on page 52)
4. Mount the field terminal on its field bracket and then secure the assembly onto the survey pole. The rover is now ready for use.

Backpack-Mounted Rover

The Z-Max.Net backpack is designed to allow users to comfortably carry the unit in the pack while using a range pole to precisely center the GPS antenna over the survey point. The backpack has adjustable shoulder and hip straps, and an adjustable torso bar. The backpack should be properly adjusted for the user.

1. Backpack

1. Connect the system components (power module, communication module) as explained on page 19 taking into account the information provided in the table on page 28 to determine which components should be used.
- 
2. Insert the Max RF adapter into the antenna receptacle at the top of the receiver module. Make sure the base of the adapter is oriented so that the flattened area is lined up with the flattened area of the receptacle, and the module can easily be pushed into place. Once in place, twist the threaded collar until the antenna is securely locked in place.
 3. Place the receiver onto the backpack and secure the unit with the Velcro strap.
 4. Connect the RF cable(s) to the Max RF adapter (GPS RF cable only or GPS RF cable *and* UHF -RF cable if you are using a UHF data link).
- 

2. Pole

1. Screw the range pole RF adapter onto the top of the 5/8 inch threaded survey pole or adapter bolt. The range pole RF adapter is exactly the same height as the receiver module **in order to keep the same antenna HI as the Z-Max pole-mounted system.**





2. Insert the UHF antenna module (or void UHF antenna module, depending on the data link used) into the top of the range pole RF adapter (same principle for assembling these elements as in 2. above).



3. Place the Z-Max.Net backpack on your back and adjust the straps so that you feel comfortable to carry the system. Be careful not to damage the ends of the RF cables when doing this.

4. Connect the free end of the GPS RF cable coming from the backpack to the range pole RF adapter.

5. If you are using a UHF radio, connect the free end of the UHF RF cable coming from the backpack to the range pole adapter.



6. Determine the height of the range pole (see *Hr* opposite). If you are using a standard pole, this height is given by the pole manufacturer so you don't need to measure it. You will later have to remember this height when setting the rover (see point 2. on *page 52*).

7. Mount the field terminal on its field bracket and then secure the assembly onto the survey pole. The rover is now ready for use.

Establishing Bluetooth Communication with Z-Max.Net



Introduction

This section explains how to control the Z-Max.Net system from a Bluetooth-enabled field terminal (Thales MobileMapper CE).

Please carefully read these preliminary notes:

- When using Bluetooth communication, **you will be asked repeatedly to enter the Z-Max PIN number** while setting up the base or the rover. By default, the PIN number for all Z-Max units is “12345”.

To enter the PIN number using MobileMapper CE’s virtual keyboard, follow the instructions below:

- To display the virtual keyboard, tap  in the task bar and then Keyboard. Don’t forget to tap inside the Enter PIN field before entering the PIN number.
- To hide the virtual keyboard, tap  in the task bar and then Hide Input Panel. If the task bar is hidden by the virtual keyboard, first tap and hold the keyboard’s title bar and move it upward until the task bar becomes visible, then select Hide Input Panel from the task bar.

- The “Tap and hold an item” instruction mentioned several times in what follows means you have to:
 - Tap on the item using the stylus
 - And keep the stylus in contact with the screen until dots and then a pop-up menu appears. Then you will have to tap one of the functions in the prompted menu.

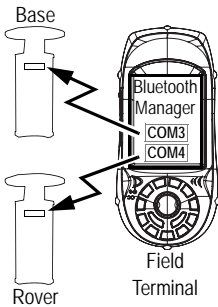

Powering up the Whole Equipment

It is assumed that the base and rover you have set up are next to each other.

1. First of all, turn on each of the Z-Max.Net units you will be using (a base and a rover, or simply a rover) by pressing the power button for about two seconds until a beep is emitted.
2. Press the red Power button on the MobileMapper CE until the Power LED lights up (green).

Detecting Bluetooth-Enabled Devices

In this step, you will run Bluetooth Manager to find the Bluetooth-enabled devices within range of the field terminal.

1. On the MobileMapper CE, tap  in the task bar, then Settings and then Control Panel.
2. Double-tap the Bluetooth Manager icon.
3. In the Bluetooth Manager window, tap on the ON button. Wait until Bluetooth Manager has detected the Z-Max.Net unit(s) you have just turned on. Bluetooth Manager will also detect any Bluetooth-enabled devices present in the vicinity such as cell phones, computers, etc. (The larger the number of Bluetooth-enabled devices, the longer the time to detect all of them.)
4. In the Authentication Request window that appears following the detection of the Z-Max.Net units, tap successively the PIN number for each unit (“12345” by default, yours may be different) (see *Introduction on page 32* to do this).
5. Tap OK. Bluetooth Manager then updates the list of Bluetooth-enabled devices to show the serial number of the Z-Max.Net units (rather than obscure Bluetooth ID numbers).



Finding Bluetooth Services

In this step, you will list the services available from the detected Bluetooth-enabled devices.

For each detected Z-Max.Net unit, do the following:

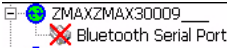
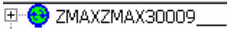

1. Tap and hold the now green Z-Max.Net icon in the list and then tap Find Services from the pop-up menu. Wait until a “+” sign appears before the icon.
2. Expand the Z-Max.Net icon by tapping on the “+” sign. This unveils Bluetooth Serial Port that is currently red crossed. (“Bluetooth Serial Port” is the only Bluetooth service available from the Z-Max.Net units.)

Assigning Virtual Ports to Bluetooth

In this step, you will ask Bluetooth Manager to assign a virtual port in the field terminal for each Bluetooth connection you need.

For each detected Z-Max.Net unit, do the following:

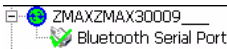

1. Tap and hold Bluetooth Serial Port and then tap Configure. This opens the Configure Serial Port window.
2. Select a free virtual port (COM3: for the base, COM4: for the rover) and then tap OK to close the window.
3. Tap and hold Bluetooth Serial Port and then tap Connect. Re-enter the PIN number if requested. Wait until the Bluetooth Serial Port line appears with a green mark meaning that the Bluetooth connection with the Z-Max.Net is now established.

Saving Bluetooth Serial Port Settings

You will save much time when next starting your system if you follow the procedure below the first time you set up the required Bluetooth connections.

For each detected Z-Max.Net unit, do the following:

1. Tap and hold Bluetooth Serial Port and then tap successively Auto Connect and then Save Settings.

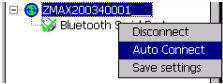

With these options activated, and **provided you do not turn off Bluetooth Manager before shutting down the field terminal**, Bluetooth Manager will automatically restore the Bluetooth connections when you next turn on your field terminal.

Obviously, Bluetooth Manager will only be able to restore connections with the Z-Max units that are present in the vicinity and powered up at that time.

You will then simply be asked to re-enter the PIN number for each of these units.

Before moving on to FAST Survey, do the following.:

2. Tap OK in the upper-right corner to close the Bluetooth Manager window. This does not turn off Bluetooth Manager but simply frees the screen for other tasks.
3. For the same reason, close the Control Panel window.

Note the presence of the Bluetooth icon () in the task bar meaning that Bluetooth continues to be active.

Defining/Saving Bluetooth Settings for FAST Survey

FAST Survey can communicate with only one Z-Max.Net unit at a time. This step provides the procedure to let FAST Survey communicate with the desired Z-Max.Net unit via Bluetooth and save these settings in a configuration file so these settings can quickly be restored whenever necessary.

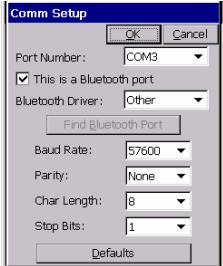

1. Run FAST Survey on the field terminal
2. In FAST Survey, tap on the Equip tab and then on the Comm Setup function.
3. In the Port Number field, select “COM3” (for communicating with the base)
4. Check the This is a Bluetooth port option and then select “Other” as the Bluetooth Driver
5. Tap OK to close the window. FAST Survey is now communicating with the base through COM3. At this stage, you can communicate with the base for configuration or monitoring purposes.
6. Tap  on top of the screen
7. Tap the Save button
8. Name the configuration file (for example “Z-Max Base”)
9. Tap OK and then Close
10. Repeat the above steps 2 to 9 for the Z-Max.Net rover you are using. This time you will select “COM4” and not “COM3” in the Comm Set up window (point 3.) and you will enter “Z-Max Rover” as the name for the configuration file (point 8.).

toggling Bluetooth Between Base and Rover

Now that you have saved the two ways FAST Survey can communicate with your Z-Max.Net system, it's easy, from the field terminal, to toggle Bluetooth communication from the base to the rover or the other way around:

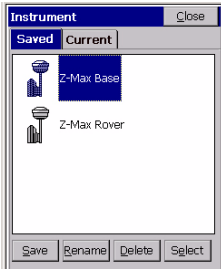

1. Tap  on top of the screen
2. Tap on the name of the configuration corresponding to the unit you wish to communicate with and then tap Select. As a result, FAST Survey automatically updates the settings in the Comm Setup function to let you communicate with the chosen unit.

Introduction to Base / Rover Configuration

Field Terminal Vs. Front Panel Interface

Because configuring an RTK base or rover is easier from a field terminal running FAST Survey rather than from the front panel interface, this chapter first presents procedures based on the use of a field terminal (MobileMapper CE).

However, using the front panel interface is possible for this task although some RTK-specific parameters will not be accessible in this case (see *Running an RTK Survey from the Front Panel on page 71*). For more information on the front panel interface, see *Operating Z-Max.Net from its Front Panel on page 123*.

Communication Choices

There are two ways of communicating with a Z-Max.Net base or rover from a field terminal for configuration purposes:

- *Via Bluetooth.* Using this communication device eliminates the need for a cable but requires going through a specific procedure before starting using it. This procedure is discussed in *Establishing Bluetooth Communication with Z-Max.Net on page 32*.
- *Via a serial line.* Typically, you connect a serial data cable between port A on the Z-Max.Net unit and the serial port on the field terminal.

On MobileMapper CE, the serial port (COM1) is located on the I/O module and uses a SubD-9m connector.

When using a serial line, you just have to select the right port ID in FAST Survey's Equip tab>Comm Setup function before starting configuring the Z-Max.Net unit.

Launching FAST Survey

1. On the field terminal, launch the FAST Survey software by double-tapping on the FAST Survey icon. 
2. Choose Select New/Existing Job. A new screen is now displayed.
3. In the Name field, type in the name of the job you wish to create. For example, type in "Job1.crd". The job concept allows you to define a number of parameters, such as units, that are common to both the base, if you own one, and the rover.

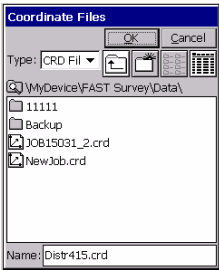

Note that FAST Survey has its own, large, virtual keyboard (see opposite). If you tap inside the Name field, FAST Survey will automatically display its virtual keyboard. You just have to type in a name using this keyboard and then tap OK.

4. Tap OK to create the job. The screen then displays the Units tab.
5. On the Units tab, set the desired units and parameters for the job.
6. Tap on the GPS tab.
7. On the GPS tab, choose the coordinate system to be used in the job as well as the geoid model. Note that the coordinate system and the geoid model may have been uploaded earlier to the field terminal using one of the GNSS Solutions tools (see *GNSS Solutions Reference Manual* for more information). A large number of coordinate systems are stored in FAST Survey. To select one of them, tap on the Edit Projection List button and then Add Predefined.
8. After selecting all the desired parameters, tap OK (located on top of the screen).

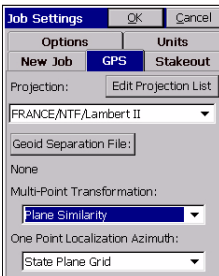

Saving Base and Rover Settings

When you configure your base or rover from FAST Survey, a Save operation is automatically performed at the end of the procedure and so you don't need to save anything manually.

After a power cycle, your base or rover will therefore continue to operate according to the last loaded configuration.

On the contrary, if you configure your base or rover from the front panel interface, you must save these parameters manually by going to **SETTINGS>SAVE**.

Configuring the RTK Base

Configuring a base always implies:

- Entering the survey system type and antenna height
- Specifying the type of data link used
- Entering the base position and ID
- Setting the data link.

Setting Communication with the Base

It is assumed that Bluetooth is used to communicate with the Z-Max.Net but remember you can also always establish communication with Z-Max.Net via a conventional serial line.

It is also assumed that you have followed the instructions presented in *Defining/Saving Bluetooth Settings for FAST Survey on page 36*. Then do the following using FAST Survey:

1. Tap on the Equip tab, then the Instrument function, select “Thales/Ashtech” from the scroll-down menu and finally tap OK.
2. Tap  on top of the screen.
3. Tap on the name of the configuration corresponding to the base (e.g. “Z-Max Base”) and then tap Select. As a result, FAST Survey automatically updates the settings in the Comm Setup function to let you communicate with the base.

Alternately, you can tap on the Comm Setup button on the Equip tab and then, in the Port Number field, select the port you assigned to communicate with the base (see point 2. in *Assigning Virtual Ports to Bluetooth on page 34*). Also, enable “This is a Bluetooth port” and select “Other” as the Bluetooth Driver. Then tap OK

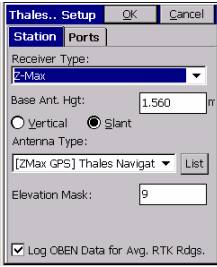

Entering Survey System Type & Antenna Height

1. Tap on the Configure Base button and then choose “Z-Max” from the Receiver Type scroll-down menu.
2. Enter the antenna height you measured previously (see point 5. *page 25*) as well as the method you used for this measurement. If you used the method described on *page 25*, check Slant.
3. Select the type of GPS antenna used, i.e. “[Z-Max GPS] Thales Navigation” as you are using the Z-Max.Net antenna directly connected to the receiver.
4. Keep or change the current value of Elevation Mask, depending on the environmental conditions of reception at the base.

Choosing the Data Link Device, Data Format and Ports

1. Tap on the Ports tab. Specify the data link used (in the Type field) and the format used to transmit RTK correction data (in the Message Type field) depending on your base setup. Any format can be associated with any data format. The table below lists all the possible data links and data formats.

Data Link	RTK Correction Data Format
GSM	Ashtech (CPD)
PDL (Pac Crest Radio)	CMR (Trimble)
THL (Thales Radio)	RTCM-(RTK)
Cable (to external transmitter via serial line)	RTCM-(DIFF)
Satel (Satel radio)	CMR+ (Trimble)
	RTCM3.0

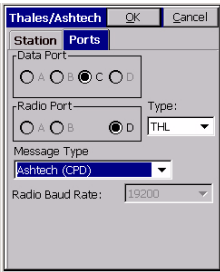

2. Also, specify the Data Port, the Radio Port and the Baud Rate used.

In some cases, the port settings will be software-set without the possibility to change them. For example, the data port will necessarily be “C” if you use Bluetooth, and the radio port will necessarily be “D” if you use a GSM modem or a Thales radio.

With the Thales radio, the Baud Rate is 19200 Bd necessarily. With the other devices, it can be different.

3. Tap OK to send these parameters to the Z-Max.Net receiver. Re-enter the PIN number. The Z-Max.Net emits a beep. A new menu appears asking you to enter the initialization position for the base.

Entering the Base Position and ID

As shown on the two screens below, up to six different options are possible to enter the base position:

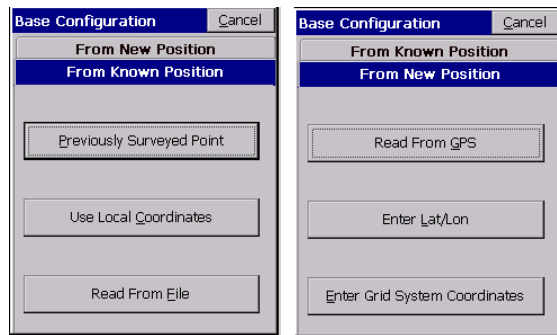

1. Refer to the table below to know what to do to, depending on whether the base position is known or not.

Is base position known?	Suggested Entry Mode	Action Required
No (New)	Read From GPS	<ul style="list-style-type: none"> - Specify number of samples - Tap OK. Wait until all samples have been collected - Check position result displayed - Tap Yes to confirm base position and continue
	Enter Lat/Lon	<ul style="list-style-type: none"> - Enter latitude/longitude coordinates - Enter Height - Specify height type (orthometric or above ellipsoid) - Tap OK - Check position displayed - Tap Yes to confirm base position and continue
	Enter Grid System Coordinates	<ul style="list-style-type: none"> - Enter Northing/Easting coordinates - Enter Elevation - Specify Elevation type (orthometric or above ellipsoid) - Tap OK - Check position displayed - Tap Yes to confirm base position and continue
Yes (Known)	Previously Surveyed Point	<ul style="list-style-type: none"> - Tap list icon to list all point IDs in job - Select point ID from list - Tap OK - Check position displayed - Tap Yes to confirm base position and continue
	Use Local Coordinates	<ul style="list-style-type: none"> - Specify point ID from file or enter local coordinates
	Read From File	<ul style="list-style-type: none"> - Browse field terminal to find REF file containing base position - Tap OK - Check position displayed - Click Yes to confirm base position and continue

Base Setup

OK Cancel

Reference Station ID:

0001

2. FAST Survey then asks you to enter the Reference Station ID (4 characters max.).
3. Enter the ID you would like to assign to the base and then tap OK. The message “Connecting to Receiver” is displayed and a beep is emitted meaning that the Z-Max.Net is being configured.

After a few seconds, FAST Survey prompts you to check the settings of the data link device (for radio data link only) (Continued in the next section *Setting the Data Link Device*).

If you chose “Cable” as the data link type, i.e. you are using an external RTK correction data transmitter, like for example an external modem, no additional settings are required and FAST Survey directly prompts you to save the settings to a REF file.

Setting the Data Link Device

For this step, what you have to do depends on the type of data link device you will be using. All possible cases of use are discussed below.

If you chose “Cable” as the data link type, no extra settings are needed.

GSM

If you are using a GSM, FAST Survey will automatically read the modem settings after the base has been configured. After a few seconds, a new screen such as the one shown opposite will appear.

This screen shows that the base GSM is ready for a call from the rover (GSM STATUS:READY). After a while, this screen also indicates the level of GSM signal, as received from where the base is sited. The higher this level the better the data link will be.

Do the following:

1. Tap on the Close button. FAST Survey displays “Base Configuration Successful. Save Settings to File?”
2. Tap Yes to save the settings. Name the REF file in which the settings will be saved and then tap OK to create this file. This completes the base configuration phase.

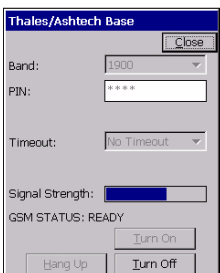

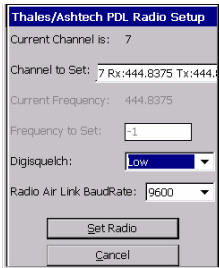

Pac Crest Radio (PDL)

If you are using a PDL Radio, a new screen appears after you confirm that you want to view the radio settings (see opposite). Do the following:

1. Set the carrier frequency and channel as well as the Digisquelch and the baud rate.
2. Tap on the Set Radio button.
3. Wait until FAST Survey displays “Base Configuration Successful. Save Settings to File?”
4. Tap Yes to save the settings. Name the REF file in which the settings will be saved and then tap OK to create this file. This completes the base configuration phase.

Thales U-Link Radio

If you are using a Thales Radio, a new screen appears after you confirm that you want to view the radio settings. In the US, a channel/frequency table will be shown. In Europe (see example opposite), a single channel will be displayed along with the corresponding frequency.

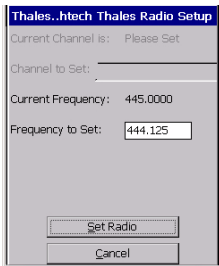

1. For example, if the frequency must be set to 444.125 MHz (it’s always a multiple of 12.5 kHz), type in “444.125” in the Frequency to Set field and then tap Set Radio.
2. Wait until FAST Survey displays “Base Configuration Successful. Save Settings to File?”.
3. Tap Yes to save the settings. Name the REF file in which the settings will be saved and then tap OK to create this file. This completes the base configuration phase.

Cable

As mentioned earlier, no extra settings are needed in this case. On the external device, you should however make sure it uses the right baud rate to communicate with the Z-Max.Net unit and it is compatible with the message type you selected (see *Choosing the Data Link Device, Data Format and Ports on page 42*).

Monitoring the Base

Regardless of the data link device used, do the following to check that the base is functioning correctly.



1. Check the LEDs on the Z-Max.Net front panel (refer to *page 15* to read the meaning of each LED). Typically, two LEDs should blink green as shown opposite.
2. You can also monitor the Z-Max.Net rover from the MobileMapper CE screen using FAST Survey's Equip tab>Monitor Skyplot function (see figure below).

Monitor/Skyplot		Back
SATView		SATInfo
Monitor		Ref
		Lat/Lon
Current position	Northing:	262588.0644
	Easting:	309294.2656
	Elevation:	46.5346
Computation	HRMS:	0.013
uncertainties	VRMS:	0.015
GPS constellation	PDOP:	1.9
geometry	HDOP:	1.2
	TDOP:	1.1
	Status:	AUTONOMOUS
Number of received satellites	SATS:	7
		Reset RTK

Tap Back to return to the menu.

3. You can now let the base operate on its own and move on to the rover configuration. Keep the field terminal on. Also, keep FAST Survey running and leave the job open as this is needed to configure the rover (see hereafter).

Configuring the RTK Rover

Preamble

General Procedure

Configuring a rover can be split into four distinct steps:

1. Establishing Bluetooth Communication with the RTK Rover (see *page 51*)
2. Setting the Parameters and Receiver tabs in FAST Survey's Configure Rover function. These settings are common to all data link configurations (see *page 52*)
3. Setting the Ports tab in FAST Survey's Configure Rover function. The choices made on this tab depend on the data link used. The following cases should be considered:
 - GSM data link (*page 53*)
 - PDL radio data link (*page 54*)
 - Thales radio data link (*page 55*)
 - External device (*page 56*)
 - NTRIP via a GPRS data link (*page 57*)
 - GPRS/IP via a GPRS data link (*page 60*)
4. Checking that the RTK Rover calculates fixed solutions.

Selecting the Right RTK Correction Data Format

One of the most important aspects when configuring a rover is making sure you select the data format that is compatible with the base you will be using.

The table below tells you which data format (called “Message Type” in FAST Survey) to select in the rover as a function of the data format transmitted by the base.

If the base transmits:	Then select the following format in the rover
Ashtech (CPD)	Ashtech (CPD/DSNP LRK)
CMR (Trimble)	CMR/CMR+
RTCM - (RTK)	RTCM-RTK
RTCM - (DIFF)	RTCM - DIFF
CMR+	CMR/CMR+
RTCM3.0	RTCM3.0

You may not have your own base in which case you should know the data format transmitted by the selected base. The RTCM-FKP data format falls within this category of data format provided by a station network in Germany.

Other networks may broadcast their data in such formats as RTCM3.0, RTCM-RTK (RTCM2.3), etc. It is your responsibility to get this information from your RTK correction data provider before you configure your rover.

When NTRIP is used, Z-Max.Net is capable of identifying the format transmitted by the selected base or base caster.

The RTCM-DIFF format only allows the rover to determine float solutions.

Saving/Restoring Your Data Link/Format Configurations

FAST Survey lets you save all your different data link / format configurations so you can easily switch from one to the other through a single tap on the screen.

This is particularly useful when using NTRIP for example as this operating mode requires that you enter a larger number of setting parameters compared to the other modes.

Through this save function, any of your settings can easily be retrieved thus allowing you to save time and avoid data entry errors.

Context of use in FAST Survey:

Equip menu, Configure Rover function, Ports tab.

Creating/Saving a new data link configuration:

- Select “Manual” in the Base Config field (bottom of the screen)
- Set the different parameters on this tab (Type, Message Type, etc.)
- Tap on the Add button
- Name the configuration you have just defined and then tap OK.

FAST Survey returns to the Ports tab on which all the parameters are now dimmed except for the Bas Config field which now shows the name of the newly created configuration.

The Add button has been replaced with the Edit and Delete buttons, which allow you to edit or delete the configuration whose name is currently shown in the Base Config field.

Selecting/Sending a saved configuration:

- Just select the name of this configuration in the Config Base field. As a result, the rest of the Ports tab is updated to reflect this configuration. You just have to tap OK to send this configuration to the rover.

NOTE: When you select NTRIP or GPRS/IP, you have to tap on the Add button to enter all the parameters relevant to these operating modes. It is therefore quite naturally that in such cases you will want to save these configurations.

Establishing Bluetooth Communication with the RTK Rover

It is assumed that Bluetooth is used to communicate with the Z-Max.Net but remember you can also always establish communication with Z-Max.Net via a conventional serial line.

It is also assumed that you have followed the instructions presented in *Defining/Saving Bluetooth Settings for FAST Survey on page 36*. Then do the following using FAST Survey:

1. Tap  on top of the screen
2. Tap on the name of the configuration corresponding to the rover (e.g. “Z-Max Rover”) and then tap Select. As a result, FAST Survey automatically updates the settings in the Comm Setup function to let you communicate with the rover.

Alternately, you can tap on the Comm Setup button on the Equip tab and then, in the Port Number field, select the port you assigned to communicate with the rover (see point 2. in *Assigning Virtual Ports to Bluetooth on page 34*). Also, enable “This is a Bluetooth port” and select “Other” as the Bluetooth Driver. Then tap OK.

Settings Common to All Data Link Configurations

Thales.. Setup OK Cancel

Parameters Receiver Ports

Multipath Type: Medium: Default

Rod Hgt: 2.35 m Vertical
 Slant

Elevation Mask: 9

Ambiguity Fixing Parameter: 99.0

Fast CPD

Thales.. Setup OK Cancel

Parameters Receiver Ports

Receiver Type: Z-Max

Antenna Type: [ZMax GPS UHF] Thales f List

Turn Beep Off

Log OBEN Data for Averaged RTK Readings

1. In FAST Survey, tap on the Equip tab and then on Configure Rover
2. On the Parameters tab, enter the following data:
 - Rod Hgt: Rod height (from which the real antenna height is deduced). If unknown, this measurement is made during the rover setup. See point
 - Height measurement type (Slant or Vertical). Usually Vertical for the rover.
 - Elevation Mask: Choose the elevation angle, seen from the rover's GNSS antenna, under which GPS satellites are not used.
 - Keep the other parameters with their default values.
3. Tap on the Receiver tab and check that the receiver used is "Z-Max". Also, as you are using a UHF antenna module -a real or void one- between the GNSS antenna and the receiver module, select the "[Z-Max GPS UHF] Thales Navigation" antenna in the Antenna Type field.
4. Keep the other parameters with their default values. You still have to make settings on the Ports tab. As explained earlier, these settings are tied to the type of data link you are using (continued on the next pages; among the 6 sections presented, read the one that corresponds to your case of use).

RTK Rover Using a Conventional GSM Data Link

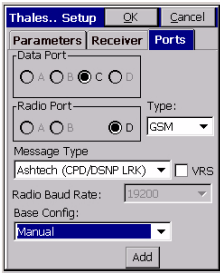

1. Tap on the Ports tab and make the following settings:
 - Base Config field (at the bottom): “Manual”. For optimum use of this field, please refer to *Saving/Restoring Your Data Link/Format Configurations* on page 50.
 - Type: “GSM”
 - Data Port: “C” (Bluetooth connection to field terminal)
 - Radio Port: “D” (necessarily)
 - Message Type: Set this parameter according to the data format transmitted by the base you will be using. (See also *Running an RTK Survey on page 63*)



2. Tap the Add button and enter the following parameters:
 - Name: Name the GSM configuration you are creating.
 - Band: Indicate the frequency band of your GSM modem (1900 or 900/1800 MHz)
 - PIN: Enter your pin number (optional)
 - Base Phone #: Enter the phone number of the base GSM modem
 - Timeout:
 - Redials:



3. Tap the OK button twice. The message “Connecting to Receiver” is displayed and the Z-Max.Net emits a beep meaning that it’s being configured.
4. After a few seconds, another screen is displayed showing that the GSM is ready for use. After a while, the screen also indicates the level of GSM signal, as received from where the rover is located (see screen opposite). The higher this level the better the data link will be.
5. Tap the Dial button to call the base GSM modem.
6. Once the connection is established, tap the Close button. After a few seconds, the RTK Solution LED (far left) should blink green meaning that the RTK position solution is fixed.

RTK Rover Using a PDL Radio Data Link

- Tap on the Ports tab and make the following settings:
 - Base Config field (at the bottom): “Manual”. For optimum use of this field, please refer to *Saving/Restoring Your Data Link/Format Configurations on page 50*.
 - Type: “PDL”
 - Data Port: “C” (Bluetooth connection to field terminal)
 - Radio Port: “D” necessarily with PDL in communication module
 - Message Type: Set this parameter according to the data format transmitted by the base you will be using. (See also *Running an RTK Survey on page 63*)
- Tap the OK button located on top of the screen. The message “Connecting to Receiver” is displayed and the Z-Max.Net emits a beep meaning that it’s being configured.
- After a few seconds, another message is displayed prompting you to check the radio settings:

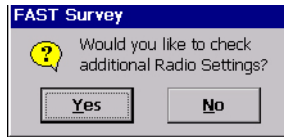
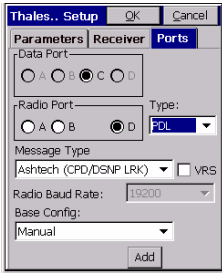

- Tap Yes. A new screen is displayed on which you can set the reception frequency and channel as well as the Digisquelch and the baud rate.
- After making all the settings, tap on the Set Radio button.
- Wait until FAST Survey returns to the Equip menu and emits a two-tone beep meaning that the rover is now configured and ready for use.

RTK Rover Using a Thales Radio Data Link

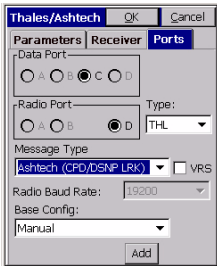

1. Tap on the Ports tab and make the following choices:
 - Base Config field (at the bottom): “Manual”. For optimum use of this field, please refer to *Saving/Restoring Your Data Link/Format Configurations on page 50*.
 - Type: “THL” (Thales radio)
 - Data Port: “C” (Bluetooth connection to field terminal)
 - Radio Port: “D” necessarily
 - Message Type: Set this parameter according to the data format transmitted by the base you will be using. (See also *Running an RTK Survey on page 63*)
2. Tap the OK button located on top of the screen. The message “Connecting to Receiver” is displayed and the Z-Max.Net emits a beep meaning that it’s being configured.
3. After a few seconds, another message is displayed prompting you to check the radio settings:

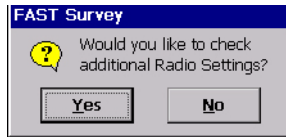

4. Tap Yes. In the US, a channel/frequency table will be shown. In Europe, a single channel will be displayed along with the corresponding frequency.
5. For example, if the frequency must be set to 444.125 MHz (it’s always a multiple of 12.5 kHz), type in “444.125” in the Frequency to Set field and then tap Set Radio.
6. Wait until FAST Survey returns to the Equip menu and emits a two-tone beep meaning that the rover is now configured and ready for use.

RTK Rover Using an External Device

1. Tap on the Ports tab and make the following choices:
 - Base Config field (at the bottom): “Manual”. For optimum use of this field, please refer to *Saving/Restoring Your Data Link/Format Configurations on page 50*.
 - Type: “Cable” (to external device)
 - Data Port: “C” (Bluetooth connection to field terminal)
 - Radio Port: “A” or “B” depending on which port you used to connect the external device.
 - Message Type: Set this parameter according to the data format transmitted by the base you will be using. (See also *Running an RTK Survey on page 63*)
2. Tap the OK button located on top of the screen. The message “Connecting to Receiver” is displayed and the Z-Max.Net emits a beep meaning that it’s being configured.
3. Wait until FAST Survey returns to the Equip menu and emits a two-tone beep meaning that the rover is now configured and ready for use.

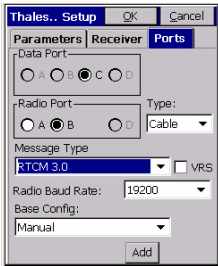

RTK Rover Using NTRIP Via a GPRS Data Link

Reminder: In this case you will be using RTK correction data from a provider using the NTRIP protocol. This means you just have to set up and use your rover. Below is the key information you need to know in this case of use:

- A GPRS data link is used to receive RTK corrections data from an NTRIP caster. The GPRS provider is assumed to have delivered the following information so you can start your modem:

Modem SIM PIN number (if any)
Access Point Name
Log in for GPRS connection
Password for GPRS connection

- The NTRIP service provider is assumed to have delivered the following information so you can access the NTRIP service:

Caster IP address (xxx.xxx.xxx.xxx)
IP port number
Log in for access to NTRIP caster
Password for access to NTRIP caster

Follow the instructions below to set up the rover:

1. Tap on the Ports tab and make the following choices:

- Base Config field (at the bottom): “Manual”. For optimum use of this field, please refer to *Saving/Restoring Your Data Link/Format Configurations on page 50*.
- Type: “NTRIP”
- Data Port: “C” (Bluetooth connection to field terminal)
- Radio Port: “D” necessarily
- Message Type: Set this parameter according to the data format transmitted by the base you will be using. (See also *Running an RTK Survey on page 63*)

2. Tap the Add button located on top of the screen.

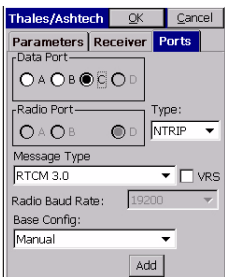

3. Enter the properties of the GPRS provider. The screen opposite only gives examples of what these properties might be.

By appropriately naming this set of information (Name field on top), you will be able to directly select this configuration from the **Base Config** field on the previous screen. See also *Saving/Restoring Your Data Link/Format Configurations* on page 50.

4. Tap the NTRIP Settings button and enter the properties of the NTRIP service you want to use. The screen opposite only gives examples of what these properties might be.
5. Tap OK three times.
6. The message “Connecting to Receiver” is displayed and a beep is then emitted indicating that the Z-Max.Net is being configured.

A new screen appears on which you can see the current status of the com module’s modem (READY; see screen opposite).

7. Tap Connect. The Connecting to Caster message is displayed. Then a new screen appears from which you can see all the stations available from your NTRIP provider
8. From the drop-down list associated with the Mount Point field, select the base station you would like to work with.

The rest of the screen provides information on the selected station. The Format field is automatically preset following the selection of a station but you can still change it if the pre-setting is incorrect (see screen opposite).

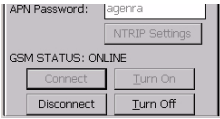

9. Tap OK. After a while, the GSM STATUS switches to ONLINE (see screen opposite) and the Z-Max.Net should start receiving corrections data. After a few seconds the RTK Solution LED (far left) should blink green meaning that the RTK position solution is fixed.

10. Tap Close.

RTK Rover Using GPRS/IP Via a GPRS Data Link

Reminder: In this case you will be using RTK correction data from a provider using a fixed IP address. This means you just have to set up and use your rover. Below is the key information you need to know in this case of use:

- A GPRS data link is used to receive RTK corrections data from a fixed IP address. The GPRS provider is assumed to have delivered the following information so you can start your modem:

Modem SIM PIN number (if any)
Access Point Name
Log in for GPRS connection
Password for GPRS connection

- The RTK correction data provider is assumed to have delivered the following information so you can access the service:

Caster IP address (xxx.xxx.xxx.xxx)
IP port number

Follow the instructions below to set up the rover:

1. Tap on the Ports tab and make the following choices:
 - Base Config field (at the bottom): “Manual”. For optimum use of this field, please refer to *Saving/Restoring Your Data Link/Format Configurations on page 50*.
 - Type: “GPRS/IP”
 - Data Port: “C” (Bluetooth connection to field terminal)
 - Radio Port: “D” necessarily
 - Message Type: Set this parameter according to the data format transmitted by the base you will be using. (See also *Running an RTK Survey on page 63*)
2. Tap the Add button located on top of the screen.

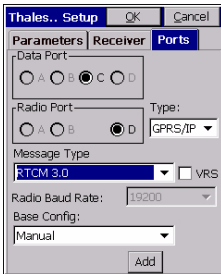

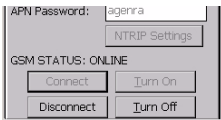
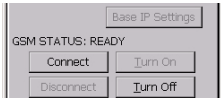
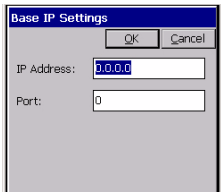
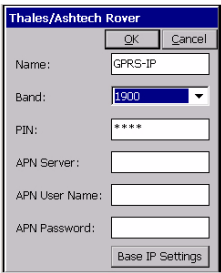

3. Enter the properties of the GSM provider. The screen opposite only gives examples of what these properties might be.

By appropriately naming this set of information (Name field on top), you will be able to directly select this configuration from the Base Config field on the previous screen. See also *Saving/Restoring Your Data Link/Format Configurations on page 50*.

4. Tap the Base IP Settings button and enter the properties of the service you want to use. The screen opposite only gives examples of what these properties might be.

5. Tap OK three times.

6. The message “Connecting to Receiver” is displayed and a beep is then emitted indicating that the Z-Max.Net is being configured.

A new screen appears on which you can see the current status of the com module’s modem (READY; see screen opposite).

7. Tap Connect. The Connecting to Caster message is displayed. After a while, the GSM STATUS switches to ONLINE (see screen opposite) and the Z-Max.Net should start receiving corrections data. After a few seconds the RTK Solution LED (far left) should blink green meaning that the RTK position solution is fixed. Tap the Close button to close the connection window..

Checking that the RTK Rover Calculates Fixed Solutions

You can first check the LEDs on the Z-Max.Net front panel to make sure the rover is now able to calculate fixed solutions from both the GPS signals it receives and the RTK correction data it receives from the base (refer to *page 15* to know the meaning of each LED). Typically, three LEDs should blink green as shown opposite.



You can also monitor the Z-Max.Net rover from the field terminal screen using FAST Survey's Equip tab>Monitor Skyplot function. Below is an example of the monitor screen when the rover provides fixed solutions.

Monitor/Skyplot		Back
SATView	SATInfo	Ref
Monitor	Lat/Lon	
Northing:	262580.0616	
Easting:	309229.8735	
Elevation:	85.2830	
HRMS:	0.015	
VRMS:	0.023	
PDOP:	2.7	
HDOP:	1.5	
TDOP:	1.8	
Status:	FIXED	
SATS:	7	
Link:	84%	Age: 2.0s
Reset RTK		

Current position

Computation uncertainties

GPS constellation geometry

Number of received satellites

Percentage of processed corrections (measured over a given period of time in relation with the age of the received corrections)

Reinitializes processing providing RTK solution

RTK Solution (Fixed)

Age of RTK correction data

Running an RTK Survey

If you have followed all the instructions provided in this *RTK Surveying* chapter to set up and configure the Z-Max.Net system, you can now start your survey using the field terminal-controlled rover.

The present section describes the main types of surveys you can perform with FAST Survey and your Z-Max.Net, namely:

- RTK point logging (Stop & Go survey)
- RTK point logging in continuous mode (trajectory survey)
- RTK staking out.

For an overview on the FAST Survey software, see *FAST Survey Software on page 115*. For a detailed description of this software, please refer to the *FAST Survey Reference Manual*.

Logging RTK Points

1. Tap on the Surv tab and then on Store Points. The screen now displayed allows you to log all your points.

The figure below summarizes all the functions available from that screen.

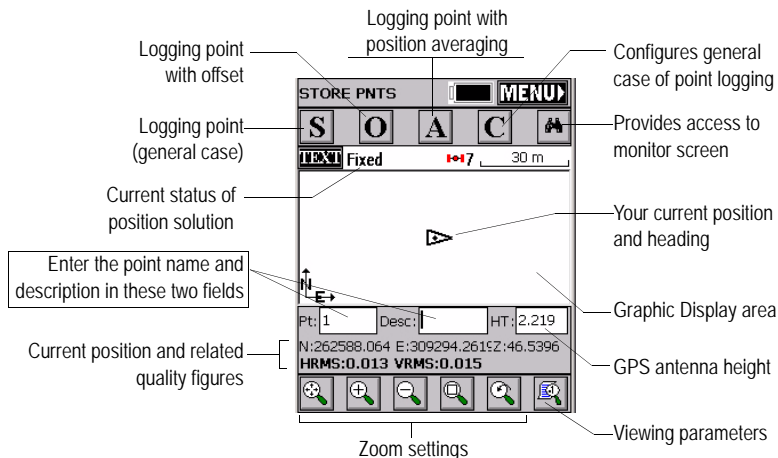

For example, you are on a point that you want to log. Do the following:

2. Type in the point name and description in the corresponding two fields (see above)
3. Tap on the “A” button
4. Enter the number of readings you want before FAST Survey is allowed to compute an average position for this point. For example, type in “5” and tap OK.

Messages follow successively indicating that the system is taking the 5 requested readings. Then FAST Survey displays the average coordinates it has determined.

5. Tap OK if you agree. The “Point Stored” message appears briefly. The screen then shows the location of the point together with its name and description.

- After logging all your points, tap **MENU** in the upper-right corner of the screen to return to the menu.

Logging RTK Points in Continuous Mode

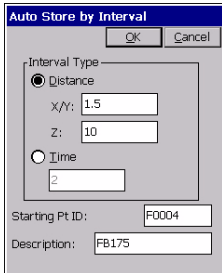

- On the Surv tab, select the Auto by Interval function. Two different modes are possible: Time or Distance.
- If you choose Distance, enter the horizontal and vertical increment value respectively in the X/Y and Z fields, according to the chosen unit. If you choose Time, enter the increment value, in seconds.
- Enter a point Id. for the start point in the Starting Pt ID field. This field will be incremented by one after each point logging. You do not need to define a name finishing with a figure. FAST Survey will place one anyway when incrementing this field.
- Press OK to switch to the graphic screen (see figure below) and start logging the first point.

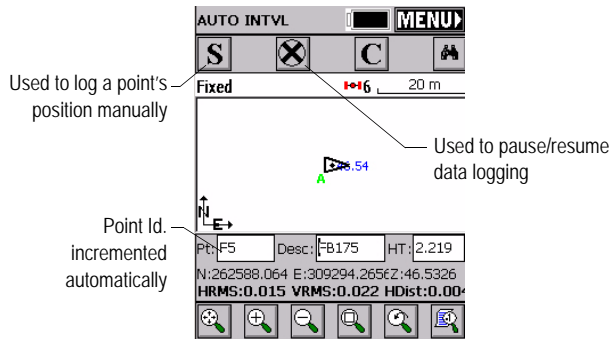

The S button lets you instantly log the position of a point. The X button allows you to pause data logging in continuous mode.

If data logging in continuous mode is paused, you can still continue to log points in manual mode using the S button.

Tap the X button again (changed into a right arrow during pause) to resume data logging in continuous mode.

If you come back to the main menu by tapping on MENU, then data logging in continuous mode is automatically stopped.

Staking out RTK Points

1. Tap on the Surv tab and then select Stakeout Points. The screen now displayed allows you to stake out your points.
2. On this screen, FAST Survey asks you to choose the point you want to stake out. You can either type in its coordinates in the Northing, Easting and Elevation fields, or select a pre-defined point from the points list (see File>List Points). You can also, define graphically this point by tapping on the point on the graphic screen, or define that point according to azimuth, slope and horizontal distance.

Provides access to points list.
Example of points list:

Provides access to graphic screen

Name of point to be staked out

Coordinates of point to be staked out

Stakeout Points

OK Cancel

Point ID: F0004

Source: Current Job

Add To List Pick From List

Northing: 262588.0646

Easting: 309294.2619

Elevation: 46.5336

Description: FB175

Point Azimuth: _____

by Slope: _____

Dir. H. Distance: _____

Point Details

Pt ID	Northing	Easting
* 52	262588.06	309294.26
* 53	262588.06	309294.26
* 54	262588.06	309294.26
* F0004	262588.06	309294.26
* F5	262588.07	309294.26
* F6	262588.07	309294.26
* F7	262588.09	309294.27
* F8	262588.07	309294.27
* F9	262588.06	309294.26
* F10	262588.06	309294.26

3. Once you have chosen a point, tapping on the OK button will display a graphic screen from which you can easily stake out your point:

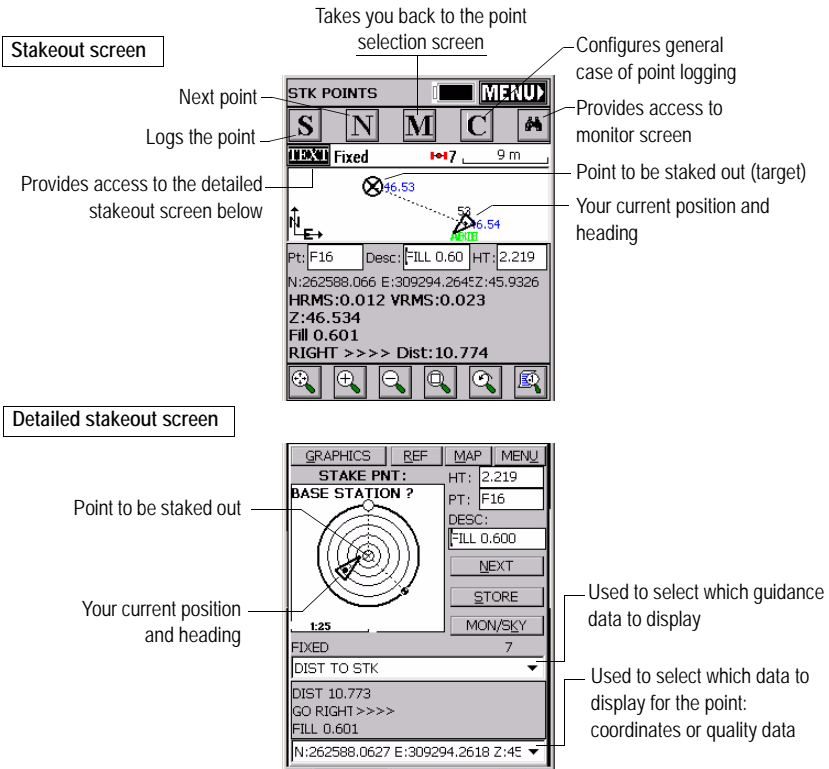

The target radius is automatically changed as the distance from you to the point changes.

When getting closer to the point, markers appear at the four corners of the target (see below left) informing you that you have arrived at the target. You can now materialize and log the position of this point.

4. Tapping on the STORE button allows you to start performing measurements to determine the target position.

The number of measurements will depend on the value entered earlier through the File tab>Configure Readings function. Once the position has been determined, FAST Survey displays the results of the computation so that you can check them (see below right).

5. Tap OK if you are satisfied with the results. FAST Survey will then save these results and will take you back to the stakeout screen for the next point.

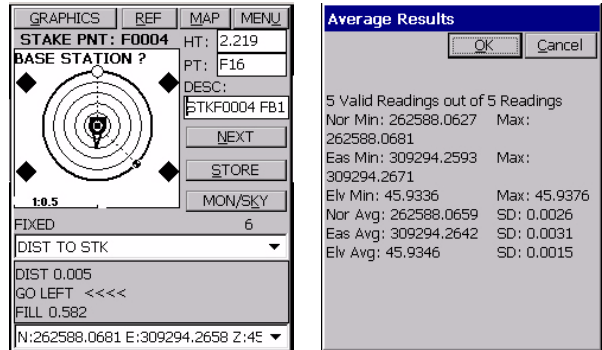

Localization (or Calibration, or Local Grid)

This operating mode is used in the following cases:

- The coordinate system should be unknown or its characteristics are not accurate enough.
- The base station is operated on a reference point whose position only results from a position determination in autonomous GPS mode.
- A local coordinate system is used for field operations.

In either of these 3 cases, you will have to calibrate your system before starting your job, using control points. The use of 3 control points or more is highly recommended to achieve horizontal calibration. This number should be raised up to 4, or more, to ensure vertical calibration, as this will guarantee the consistency of your control points.

Click on the Equip tab and select Localization. The screen that now appears is described below.

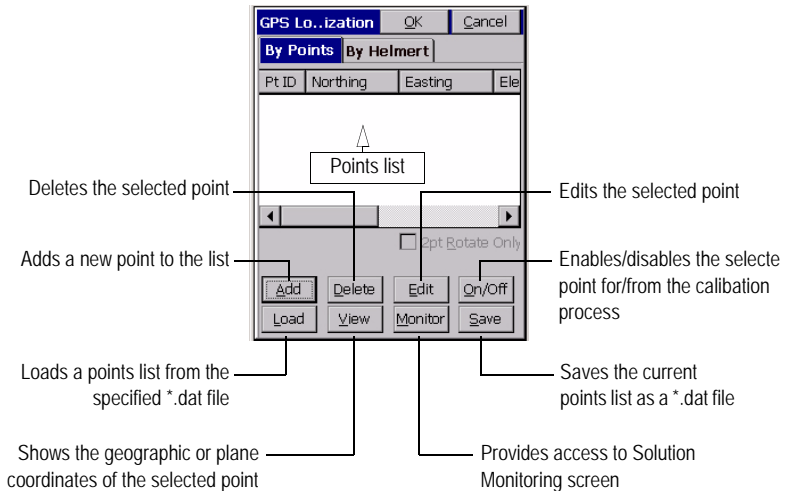

Control coordinates can be entered manually or read from a file stored in the handheld computer. When you click **ADD** to add a point, a new screen is displayed (see figure 25 on next page). You may either enter the points coordinates manually or select an existing point from the pre-defined list.

Click on the  button to access the list of points available from the open job.

Click **OK** after selecting a point from the list. A new screen then appears asking you to enter the true coordinates of the point. There are three different methods for entering these coordinates (see figure 26).

- They can be read from the rover receiver. In this case, the rover should be positioned over the concerned control point.
- They can be entered manually (WGS84 coordinates).
- They can be loaded from the results of a point that was logged earlier during the same job.

If you choose to use the coordinates computed by the rover receiver, then FAST Survey will ask you to indicate the number of measurement samples required before the receiver outputs the coordinates measured for the point (figure 27).

Click OK to enable the result of that computation. FAST Survey then takes you back to the screen showing the points list.

Resume the previous steps until the coordinates of all the control points involved in the calibration process have been determined by the rover receiver.

On the points list screen (figure 28), check the amount of residual for each control point involved in the calibration. The lower these values, the better the consistency of your control point network.

Should some residuals be abnormally high, the relevant point(s) should be deleted using the Delete button, or removed from the calibration process using the On/Off button.

Warning! At least 3 points are required to compute residuals in a horizontal system, and at least 4 points in a horizontal + vertical system.

The On/Off button gives access to a menu allowing you to enable/disable the selected control point for the horizontal control process, for the vertical control process, or for both (figure 29).

The calibration parameters can be saved as a *.DAT file for further use. Click on the Save button to do this.

To quit the calibration function, click on the OK button

Running an RTK Survey from the Front Panel

If you are using the front panel user interface, you have the choice of three types of RTK surveys:

- *Auto Point*
- *Trajectory*
- *Manual*

Auto Point surveys are used when you have a series of closely related sites that you wish to occupy for the same period of time.

Trajectory surveys are used for setting stakeouts, or other surveys where data is collected at fixed distance or time intervals.

Manual RTK surveys are performed when points are randomly occupied for different periods of time.

The following is a step-by-step procedure on how to set up and perform each type of RTK survey using the front panel. If you need more information about using the front panel, see *Operating Z-Max.Net from its Front Panel on page 123*.

AUTO POINT RTK Survey

In *Auto Point* RTK, a “Time To Stay” parameter is set in seconds. The receiver will collect data at each point for the duration of the “Time To Stay” parameter. After data collection has stopped, the SITE ID automatically increments by one.

Auto Point Set Up

1. Verify the SURVCONF menu is in RTK ROVER mode:

From the SURVCONF menu, use the Up or Down key until MODE is displayed. Verify that the mode is MODE:RTK ROVER. If it is not, press the Enter key and select RTK ROVER.

2. Set the positioning algorithm:

From the SURVCONF menu, access the POSITIONING sub-menu. Select the desired RTK positioning algorithm:

- COARSE will output Fast RTK positions.
- FINE will output synchronized RTK positions.

Either type is acceptable. The default is COARSE. To change this parameter, press the Enter key and select the desired algorithm.

3. Set the logging method:

From the SURVCONF menu, use the Up or Down key until LOG TYPE is displayed. Press Enter and use the Up or Down key until AUTO PT is displayed. Select AUTO PT for an Auto Point RTK survey.

4. Set the TIME TO STAY parameter:

From the SURVCONF menu, access the TIME TO STAY submenu. Enter the amount of time in seconds for which you intend to occupy each point. The range of this parameter is 0.0 to 999 seconds, but reasonable values are between 5 and 60 seconds.

5. Set the recording interval.

From the SURVCONF menu, use the Up or Down key until REC INT is displayed. The recording interval will determine the output frequency of the RTK positions. The range is dependent upon the firmware options enabled in your receiver, the output frequency of the base station data and the positioning algorithm selected in step 2. In general, the recording interval should be set to a value of 1 second or less.

Auto Point Survey Execution

1. Move the rover system to the first point to be surveyed:

Set and level the survey pole on the point. Verify that the RTK Solution LED is blinking green (the system is initialized and computes fixed RTK solutions).

2. Enter the antenna height:

Access the SURVEY:RTK ROVER submenu. Enter the ANT HT submenu and input the accurate vertical antenna height from the mark to the GNSS antenna module. This parameter will stay constant for the duration of the survey.

3. Enter the Site ID:

The Site ID submenu is in the 3rd level of the SURVEY:RTK ROVER menu. To access the 3rd level, display the LOGGING submenu and press the Enter key. Select AUTO POINT and press the Enter key.

Enter the SITE submenu and input a 4-character ID that is unique to that site, for example “PT01”. This will start RTK data logging.

NOTE: For the Site ID to automatically increment at the end of site occupation, the last character in the Site ID must be numeric.

4. Occupy point:

The receiver will log RTK position and vector data for the duration set in the TIME TO STAY parameter and at the frequency set in the REC INT parameter.

5. Monitor data logging:

There are three submenus to help you to monitor the site data logging. Use the LOG submenu to display the amount of time elapsed since the start of data logging. Use the HRMS and the VRMS submenus to monitor the horizontal and vertical positional accuracies. Also, verify that the RTK Solution LED is still blinking green.

6. Move to next point:

When data collection is complete, a message is displayed in the front panel display and the receiver stops logging data. Move to the next point and set up the survey pole in the new point.

7. Confirm new Site ID:

If the last character of the Site ID is numeric, the Site ID will automatically increment by one (for example to “PT02”). If this Site ID is correct, press the Enter key. If the Site ID is not correct, enter the correct Site ID and press the Enter key. Data logging will start at the new point.

8. Repeat steps 3 through 8 until all points in the survey have been observed. You are now ready to return to the office and download the data.

If during the survey, the RTK Solution LED blinks orange, wait until the receiver re-initializes and the LED blinks green again before occupying a point. If the LED does not become green again, you will have to troubleshoot the system to determine the problem. See *Troubleshooting on page 225* for more information about troubleshooting your system.

TRAJECTORY RTK Survey

In Trajectory RTK surveys, a “Distance Interval” parameter is set in meters. As you traverse across the site, the receiver will monitor the distance covered and log data at each interval set in the “Distance Interval” parameter. You can also collect trajectory data at set time intervals by setting the “Distance Interval” parameter to 0 and setting the “Recording Interval” parameter to the desired time interval.

Trajectory Set Up

1. Verify the SURVCONF menu is in RTK ROVER mode.

From the SURVCONF menu, use the Up or Down key until MODE is displayed. Verify that the mode is MODE:RTK ROVER. If it is not, press the Enter key and select RTK ROVER.

2. Set the positioning algorithm:

From the SURVCONF menu, access the POSITIONING sub-menu. Select the desired RTK positioning algorithm:

- COARSE will output Fast RTK positions.
- FINE will output synchronized RTK positions.

Either type is acceptable. The default is COARSE. To change this parameter, press the Enter key and select the desired algorithm.

3. Set the logging method:

From the SURVCONF menu, use the Up or Down key until LOG TYPE is displayed. Press Enter and use the Up or Down key until TRAJECT is displayed. Press Enter to select TRAJECT for a Trajectory RTK survey.

4. Set the distance interval:

From the SURVCONF menu, use the Up or Down key until DISTANCE INTERVAL is displayed. Press Enter and input the desired distance between each point. The range of this parameter is 0 to 999 meters. To perform a Trajectory RTK survey at a fixed time interval, set the Distance Interval to 0 and set the Recording Interval (step 5) to the desired time interval.

5. Set the recording interval:

From the SURVCONF menu, use the Up or Down key until REC INT is displayed. Press Enter and input the recording interval in seconds. The recording interval will determine the output frequency of the RTK positions in seconds. The range is dependent upon the firmware options enabled in your receiver, the output frequency of the base station data and the positioning algorithm selected in step 2. In general, the recording interval should be set to a value of 1 second or less. If the distance interval is set to 0 meters, set the recording interval to the desired time interval between any two consecutive RTK position solutions logged.

Trajectory Survey Execution

1. Move the rover system to the start of the trajectory. Verify that the RTK Solution LED is blinking green (the system is initialized and delivers fixed RTK solutions).

2. Enter the antenna height:

Access the SURVEY:RTK ROVER submenu. Enter the ANT HT submenu and input the accurate vertical antenna height from the mark to the GNSS antenna module. This parameter will stay constant for the duration of the survey.

3. Enter the Site ID:

The Site ID submenu is in the 3rd level of the SURVEY:RTK ROVER menu. To access the 3rd level, display the LOGGING submenu and press the Enter key. Select TRAJECTORY and press the Enter key.

Enter the SITE submenu and input a 4-character ID. This will start RTK data logging.

NOTE: For the Site ID to automatically increment at the end of site occupation, the last character in the Site ID must be numeric.

4. Move along the traverse.

As you move along your traverse, the receiver will log RTK position and vector data each time the amount of distance set in the Distance Interval parameter has been covered.

5. Monitor data quality.

There are two submenus to help you to monitor the data collection. Use the HRMS and the VRMS submenus to monitor the horizontal and vertical positional accuracies. Check the RTK Solution LED to verify that the LED is blinking green.

Continue to travel the traverse until the entire course has been observed. You can now return to the office and download the data.

If during the survey, the RTK Solution LED blinks orange, wait until the receiver re-initializes and the LED blinks green again before occupying a point. If the LED does not become green again, you will have to troubleshoot the system to determine the problem. See *Troubleshooting on page 225* for more information about troubleshooting your system.

MANUAL RTK Surveys

In Manual surveys, there are no special parameters to set. The Site ID is manually entered and you can collect data on any point for as long as you wish. Data is collected until you manually instruct the receiver to stop.

Manual RTK Set Up

1. Verify the SURVCONF menu is in RTK ROVER mode.

From the SURVCONF menu, use the Up or Down key until MODE is displayed. Verify that the mode is MODE:RTK ROVER. If it is not, press the Enter key and select RTK ROVER.

2. Set the positioning algorithm:

From the SURVCONF menu, access the POSITIONING submenu. Select the desired RTK positioning algorithm:

- COARSE will output Fast RTK positions.
- FINE will output synchronized RTK positions.

Either type is acceptable. The default is COARSE. To change this parameter, press the Enter key and select the desired algorithm.

3. Set the recording interval.

From the SURVCONF menu, use the Up or Down key until REC INT is displayed. The recording interval will determine the output frequency of the RTK positions. The range is dependent upon the firmware options enabled in your receiver, the output frequency of the base station data and the positioning algorithm selected in step 2. In general, the recording interval should be set to a value of 1 second or less.

Manual RTK Survey Execution

1. At the first point to be surveyed, set and level the survey pole on the point. Verify that the RTK Solution LED is blinking green.

2. Enter the antenna height:

Access the SURVEY:RTK ROVER submenu. Enter the ANT HT submenu and input the accurate vertical antenna height from the mark to the GNSS antenna module. This parameter will stay constant for the duration of the survey.

3. Enter the Site ID:

The Site ID submenu is in the 3rd level of the SURVEY:RTK ROVER menu. To access the 3rd level, display the LOGGING submenu and press the Enter key. Select AUTO POINT and press the Enter key.

Enter the SITE submenu and input a 4-character ID that is unique to that site, for example “PT01”.

4. Start data logging:

Data logging is initiated by the START function. Once the Site ID is entered, use the Up or Down key until START is displayed. Press Enter to start data logging.

5. Monitor site occupation:

There are three submenus to help you to monitor the data collection. Use the TE (time elapsed) submenu to display how much time has elapsed since the start of data logging. Use the HRMS and the VRMS submenus to monitor the horizontal and vertical positional accuracies. Also, verify that the RTK Solution LED is blinking green.

6. Stop data logging:

When enough data has been collected at this point, use the Up or Down key until the STOP ? function is displayed. Press the Enter key and Stop Data Logging? will appear on the display. Press Enter to confirm.

7. Move to next point:

8. Move to the next point to be surveyed and repeat steps 3 thru 6.

Continue to occupy and monitor each point until all points in the survey have been observed. You can then return to the office and download the data.

If during the survey, the RTK Solution LED blinks yellow, wait until the receiver re-initializes and the LED blinks green again before occupying a point. If the LED does not become green again, you will have to troubleshoot the system to determine the problem. See *Troubleshooting on page 225* for more information about troubleshooting your system.

Downloading RTK Results to GNSS Solutions

Back at the office, do the following to download and view the RTK results stored in the job you have just finished.

1. Prepare your field terminal for data downloading. With MobileMapper CE, do the following:
 - Clip the I/O module at the back of the unit.
 - Connect the MobileMapper CE's I/O module to the PC using the USB cable provided.
2. Switch on the field terminal and then launch FAST Survey
3. Select File>6. Data Transfer>Carlson SurvCadd/Carlson Survey.
4. On the PC:
 - Launch GNSS Solutions and then click Create a new Project
 - Name the project and click OK
 - Select the spatial reference system that was used during your RTK survey, select the appropriate time zone and then click OK
 - Click Do Not Import Anything Now. A new empty project opens in GNSS Solutions.
 - Select Tools>Preferences and make sure Show RTK functions is enabled otherwise check it and then click OK
 - From the menu bar, select Project>Download Positions from External Device
 - In the dialog that opens, select RTK Results in the left pane and then FAST Survey data collector in the right pane
 - Click OK. This opens the Data Transfer dialog box.

- To be able to configure the connection to the MobileMapper CE the first time you download RTK results, clear the **Automatic transfer** option and then click **OK**. Two error messages may appear in the next step. Just click **OK** when this happens. The **SurvCom** window then appears on the screen.
- In the **SurvCom** window, click on the **Options** button and then select the **ActiveSync** option in the upper-right combo box (this option is last in the list)
- Click **OK**. Select the “**Data**” folder on the MobileMapper CE and click **Exit**.
- In the new dialog that appears, you can now see the list of jobs stored in the MobileMapper CE
- Click on the job you want to download. The name of the selected job appears in the upper field.
- In the **Directory** field, choose the folder on your PC where you would like to store this job
- Click **OK**. RTK results are now downloaded to the project open in GNSS Solutions. At the end of the transfer, these results can be seen on the project’s **Survey** view.

NOTE: When next downloading RTK results, the connection to the field terminal does not need to be re-configured. This means you can skip this step by checking the **Automatic Transfer** option in the **Data Transfer** dialog box (see step on top of this page).

4. Post-processing Surveying

Reminder on Post-Processing Surveying Techniques

Static

Typical Use: Surveying a New Control Point.



Make sure the base is sited in a clear area giving the best possible view of the sky!

When this is possible, avoid trees, buildings or any high obstacles in the vicinity of the base.

Having a clear view of the sky will allow the base to collect data from a maximum of visible satellites, which is highly recommended to perform a successful, accurate and fast survey.

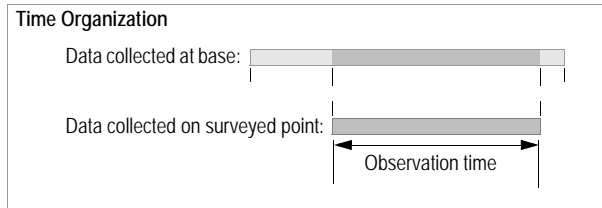
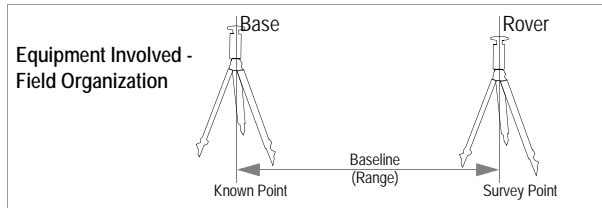

Key Instructions:

1. Two units needed: one (the base) operated on an accurately known position and the other (the rover) on the point to be surveyed. There can be several rovers logging data at the same time.
2. Approximate distance between the two units (baseline) must be known.
3. Data must be collected simultaneously by the two units. **Use the same logging interval on both units (30 seconds typically).**
4. Observation time is determined by last unit set up (start) and first unit turned off (end). We recommend that you start the base first and you turn it off last.
5. Required observation time mainly depends on distance between the two units (+ reception conditions). Rover unit estimates observation time needed.

When **Estimated Base Line Len** on the Z-Max.Net front panel decreases down to "000km", you can stop collecting data.

“Stop & Go” Kinematic

Typical Use: Surveying Several Points within a Relatively Small Area.



Make sure the base is sited in a clear area giving the best possible view of the sky!

When this is possible, avoid trees, buildings or any high obstacles in the vicinity of the base.

Having a clear view of the sky will allow the base to collect data from a maximum of visible satellites, which is highly recommended to perform a successful and accurate survey.

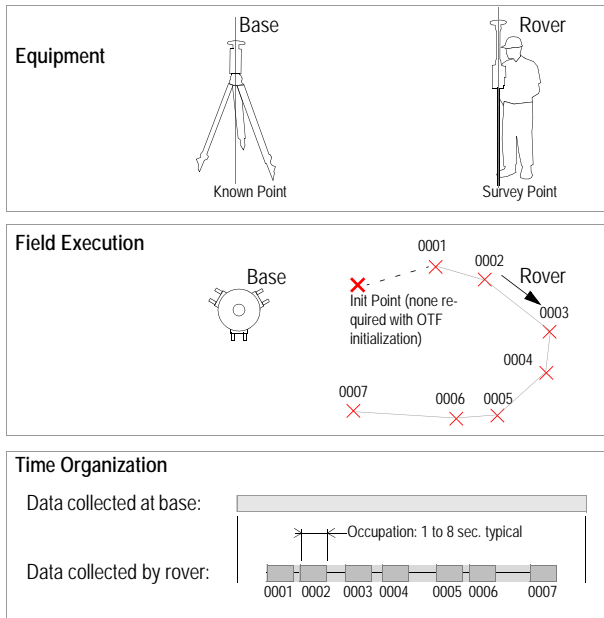

Key Instructions:

1. Two units needed: one stationary (the base) and the other (the rover) moved successively on the points to be surveyed. There can be several rovers logging data at the same time.
2. Be careful not to mask the rover's GPS antenna throughout the survey. Be aware of the initialization requirement. In case of satellite signal loss, take the necessary steps to restore initialization. See page 251.
3. Data must be collected simultaneously by the two units. We recommend that you start the base first and you turn it off last. **Use the same logging interval on both units (1-2 seconds typical).** Rover collects data continuously throughout the survey.

Continuous Kinematic

Typical Use: Surveying Trajectories.



Make sure the base is sited in a clear area giving the best possible view of the sky!

When this is possible, avoid trees, buildings or any high obstacles in the vicinity of the base.

Having a clear view of the sky will allow the base to collect data from a maximum of visible satellites, which is highly recommended to perform a successful and accurate survey.

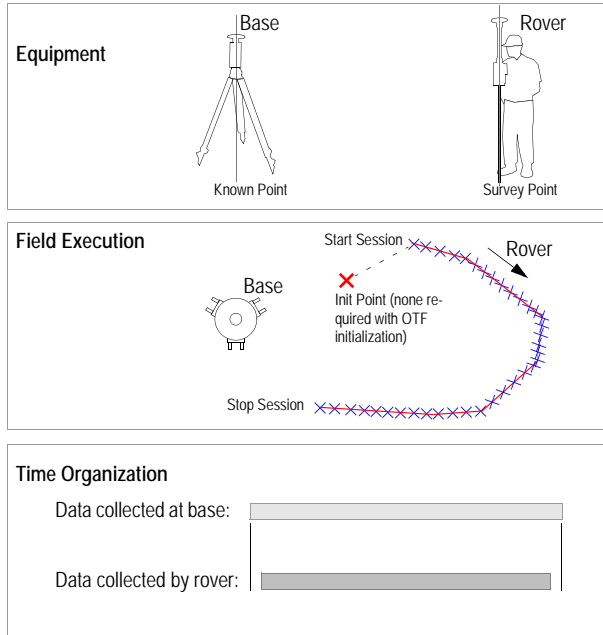

Key Instructions:

1. Two units needed: one stationary (the base) and the other (the rover) moved along each surveyed trajectory. There can be several rovers logging data at the same time.
3. Be careful not to mask the rover's GPS antenna throughout the survey. Be aware of the initialization requirement. In case of satellite signal loss, take the necessary steps to restore initialization. See page 251.
4. Data must be collected simultaneously by the two units. We recommend that you start the base first and you turn it off last. Use the same logging interval on both units (1-2 seconds typically). Rover collects data continuously throughout the survey.

The initialization phase is required to ensure that your kinematic surveys, whether continuous or Stop & Go, will reach centimeter-level accuracies through post-processing.

With the Known Point method, you can make a survey at a fairly long distance from the base.

With the OTF method, the survey start point can be any point but you should have a rough idea of the distance from your working area to the base so you can estimate the overall time you should spend collecting data (15 to 30 minutes typical).

Kinematic Initialization Methods

There are two possible methods:

- Initialization on Known point. The known point may be the result of a previous static survey.

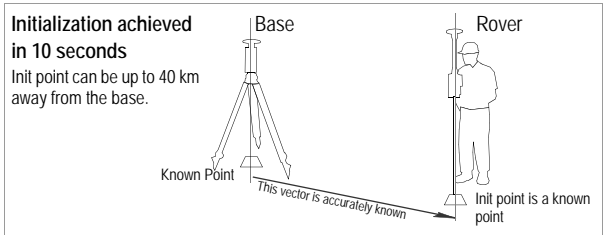

- On-The-Fly (OTF) Initialization

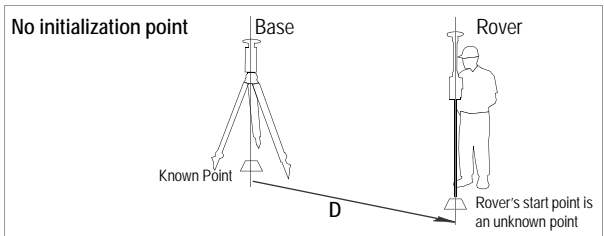

For more information about initialization, refer to *Initialization Process on page 251*

Running a Static Survey

Introduction to Static Surveying

Prior to venturing out into the field, you must first plan how you will execute your static survey. Proper planning will greatly increase the chances of success. There are two primary areas of static survey planning, the *network design* and *observation plan*. Each is discussed below.

Network Design

You have identified a survey for which you wish to use the Z-Max.Net system to establish control. Regardless if the number of control points to be established is 2 or 20, you must design a network defining the number and location of observations (vectors in our case) that will be required to effectively position the new points.

As an illustration, consider an example where two new intervisible points are to be established on a project site for use as control for a boundary survey. The two new points need to be tied to an existing control point 3 kilometers (1.9 miles) away.

Three-Point Control Survey Example

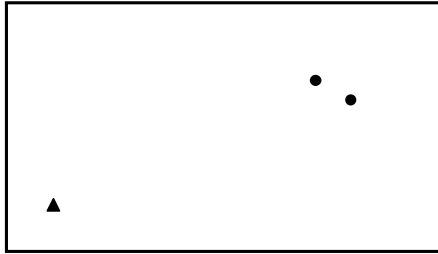

If you were to perform this survey with a conventional total station, you would probably plan on running a closed-loop traverse from the existing control point through the two new points (see figure below). The same philosophy can be used for GPS surveys. The figure below is your network design for this survey

Closed-Loop Traverse Design

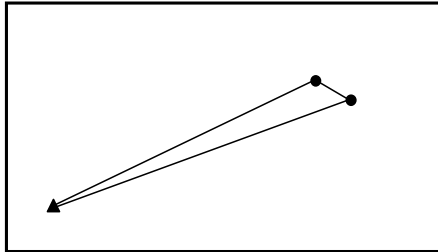

The previous example resulted in a very simple network design. The figure below represents a more complex control survey where 10 new points are to be established based on 2 existing horizontal and 3 existing vertical control points.

*15-Point Control Survey
Example*

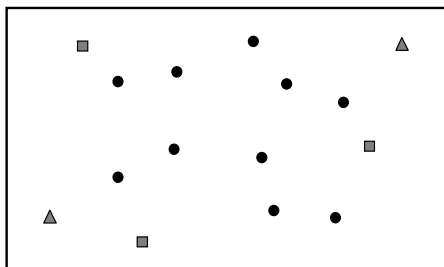

Again, if you were to perform this survey with a conventional total station, you would design a traverse plan which produced a strong looking network of closed-loop traverses through the points of the survey. The figure below shows one possible network design.

*Network Design for 15-
Point Control Survey*

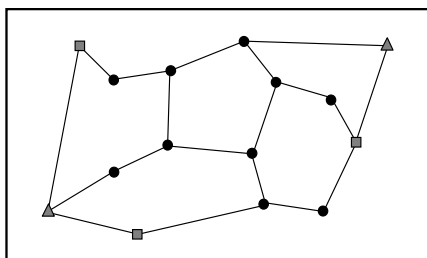

Although this network design was produced with conventional traversing in mind, this same design can also be used if performing the survey with GPS equipment.

When designing your network, keep the following principles in mind:

- Design loops through the network points which resemble a square or circle. Avoid loops that are long and skinny. Circular or square shaped loops are stronger geometrically.
- Keep the number of points in each loop fewer than 10.
- Always include a direct link between intervisible points, i.e. points which may be used as a pair for orientation of a conventional traverse. Since, in most instances, intervisible points are relatively close to each other, it is important to get a direct observation between them.

Observation Plan

With the network design completed, the next step is to determine how and when data collection will be performed to produce the desired network. First let's discuss the how.

If you were to use a conventional total station to perform our three-point survey example, your resulting traverse could probably look something like this:

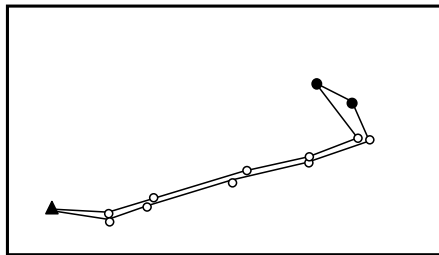

*Closed-Loop Traverse of
3-Point Control Survey*

The number of traverse legs required to traverse between each point in the network will depend upon the conditions on the ground between the points.

If you are in luck, the area is relatively flat and there is a straight road running from the existing control point to the two new points to be established, thus minimizing the number of legs required to complete the loop.

Surveying with GPS has the advantage of not requiring line-of-sight between the points surveyed. This allows for direct observations between the points. To illustrate this, let's take our 3-point control survey network design, shown again below.

Network Design for 3-Point Control Survey

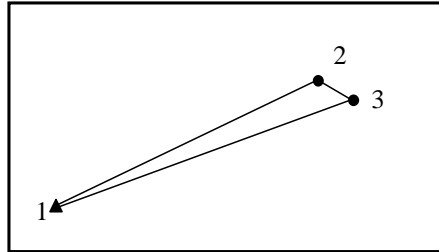

Assume that a 2-receiver Z-Max.Net system will be used to perform the above survey. To produce the link between the existing control point 1 and the new point 2, simply place one Z-Max.Net receiver system on point 1, place the other receiver on point 2 and simultaneously collect data between the two points. When the observation is complete, move the Z-Max.Net receiver from point 2 to point 3. Perform another observation, simultaneously collecting data on points 1 and 3. When completed, move the Z-Max.Net receiver from point 1 to point 2. Perform the final observation between points 3 and 2. When this data is downloaded and processed, the result will be three vectors (delta positions) forming the network design seen in the above figure.

Now consider the situation where a 3-receiver Z-Max.Net system is used. By placing one receiver on each of the 3 points in our network, the data for all three vectors can be collected in one observation, rather than the 3 separate observations required with using a 2-receiver system.

Now consider the observation plan for the more complex 15-point survey, shown again below.

Network Design for 15-Point Control Survey

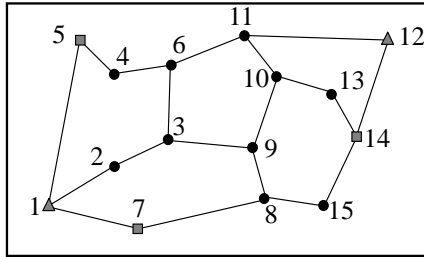

To execute this network design, you must perform a direct GPS observation between all points directly linked. Each link can be viewed as a required GPS vector. Counting the links in this network design, you will find that 19 GPS vectors are required to execute this design.

If the survey was to be performed using a 2-receiver Z-Max.Net system, 19 separate data collection sessions (observations) would be required. For example, you can start with a receiver on point 1 and another on point 2. After this observation, you would move the receiver from point 1 to point 3 to perform an observation between points 2 and 3, and so on until all vectors were observed.

Now consider the situation where the 15-point control survey above is to be performed using a 3-receiver Z-Max.Net system. With 3 receivers, each observation session will produce 2 vectors from the network design. For example, you may start by placing one receiver on point 1, the second on point 2, and the third on point 7. These three receivers would simultaneously collect data on these three points, resulting in the vectors between points 1 and 2, and points 1 and 7. In addition to these two vectors, a third vector is produced between points 2 and 7. At the end of this first observation, you could move the receiver from point 2 to point 9 and the receiver from point 1 to point 8.

The receiver at point 7 would remain as the pivot point, connecting the first observation to the second. This would continue until all vectors were observed.

The figure below shows what the observation plan might look like with a 3-receiver Z-Max.Net system.

*Receiver Observation
Plan for 15-Point Control
Survey*

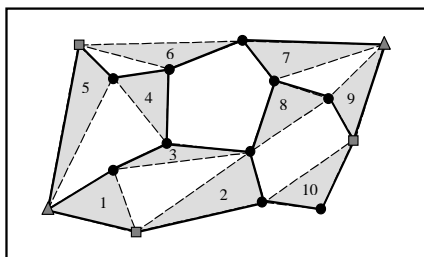

The observation plan shows that it will take 10 separate observation sessions to complete the survey based on the network design shown on page 90.

Notice that all observation sessions, except for session 6, produce 2 vectors required from the network design. Observation 6 produces only one since there were an odd number of required vectors (19).

This completes the discussion on how to execute the observation plan.

The next question to answer is “When do we perform the observations?”

The best time to perform GPS surveys is determined by an examination of the GPS satellite constellation at your location for a given time of day. The number of visible GPS satellites and the distribution of the satellites in the sky are important factors impacting the observation time required to produce quality GPS vectors.

Times when the number of visible GPS satellites is low or the satellite distribution is poor will require extended data collection periods to ensure quality results. In rare instances, availability and distribution may be so poor that you are better off not performing your survey during these periods.

Included in the GNSS Solutions processing software package is a module called Mission Planning. The Mission Planning software provides you with the tools to examine the GPS satellite constellation. Using satellite almanac information, which predicts the location of the GPS satellites into the future, you can examine satellite availability and distribution for the day(s) when you wish to perform your survey to isolate any time periods where observation times may need to be extended or periods where it is best not to collect data.

You provide the software with your current location and the date when you wish to perform your survey. The software then provides you with multiple ways of examining the satellite constellation at your location for the given time. Pay particular attention to satellite availability (number of satellites in view) and the satellite distribution.

To assist in analyzing the quality of satellite distribution, Dilution of Precision (DOP) values are presented. DOP is a quality analysis value for satellite distribution. The most popular DOP value is PDOP, which stands for Positional Dilution of Precision. The PDOP value estimates the impact on the precision of your GPS observations due to satellite geometry. The smaller the PDOP value the better the satellite distribution (geometry) and therefore the better the precision of your observations.

With the current constellation of 26+ GPS satellites, it is uncommon to find periods in the day when satellite availability and distribution are so poor that data collection should be avoided. Time of poor availability and distribution are usually short in duration.

When using the static mode of GPS data collection, where observation times are usually 20 minutes or more, short periods of poor availability and distribution can be tolerated.

When performing an observation during which a period of poor availability and distribution appears, observation times will normally need to be extended to compensate for this event.

The Z-Max.Net receiver includes two features that estimate the observation time required to produce a quality solution. These features are called “Estimated baseline length” and “Observation Timer”. These are discussed in more detail later on in this chapter. The estimated baseline length and observation timer take into account satellite availability and distribution when determining the required observation time. If you are collecting data during a period of poor availability and distribution, you will find these parameters will take longer to inform you when your survey is completed. It is automatically extending the observation period to compensate for the poor availability and distribution of satellites.

Analysis of the satellite constellation with Mission Planning prior to data collection will give you an idea of the time periods when extended observations will be required

NOTE: The Z-Max.Net receiver is designed to store GPS data for only those satellites that are at least 10° above the horizon. The receiver may lock onto a satellite between 0° and 10° but will not record this data. When using the Mission Planning software to analyze the satellite constellation, be sure to set the satellite cut-off angle to 10° . This will ensure that the satellite availability and distribution presented by Mission Planning matches what is being used by the Z-Max.Net receiver for data storage.

Static Occupation Times

A general guide for good conditions is five or more satellites tracked continuously during the occupation and PDOP less than 4.

For dual-frequency receivers, a reasonable occupation time for the Z-Max.Net system is 10 minutes plus 1 minute for every kilometer of vector length. For example, if three receivers are collecting data simultaneously and the longest vector being observed is approximately five kilometers, the simultaneous observation time would be 15 minutes. Since it takes less time to collect additional data than to return to the site on a different day, some safety factor (20% or more) added to observations is recommended.

Optimistic observation times are generally adequate when vector lengths are less than 30 km (19 miles), there are more than 6 satellites visible, obstructions are minimal, and there is very little multipath (buildings or bodies of water that reflect signals). If any of these factors is present, observation times should be increased. Experience will give you the ability to take all factors into account and determine an appropriate observation time for any given situation.

Vectors longer than 30 km (19 miles) may require occupations longer than 60 minutes. When surveying baselines in excess of 50 km (31 miles), precise ephemerides should be used.

Also be aware that ionospheric activity can negatively impact GPS measurement quality similar to the way rising heat from a hot road can negatively affect a long laser

distance measurement. Increasing occupation times can almost always compensate for ionospheric activity the way a larger prism array can enable a longer laser distance measurement on a hot day.

The “Estimated Baseline Length” and “Observation Timer” parameters in Z-Max.Net gives good indications of how long the static occupation time should be at a given point considering the environmental conditions around this point (see also *page 93* and *End of Data Collection on page 98*).

Base and Rover Setup

A typical survey is described in this chapter using a conventional tripod. No field terminal is used as controlling system operation from the Z-Max.Net front panel is quite easy in this case.

The setup instructions are the same for both the base and the rover. Install and run the base first.



Choosing the Installation Site

The installation site should offer the best possible GPS reception conditions. The GNSS antenna should have a clear view of the sky in all directions. There should be no, or a minimum of satellite obstructions in the vicinity.

Z-Max.Net Unit Setup

1. Connect the system components (power module, GNSS antenna and V- module) as explained on *page 19*.
2. A memory card is required to log raw data. Insert this card as explained on *page 20*. Formatting a memory card for the Z-Max.Net requires that you re-initialize the Z-Max.Net with the SD card inserted (see *page 21*).
3. Center and level the tripod over the ground mark.
4. Insert the brass tribrach adapter through the hole in the HI measurement plate and screw the adapter/plate into the 5/8” threaded receptacle in the bottom of the Z-Max.Net receiver module.
5. Carefully place the Z-Max.Net assembly into the tribrach mounted on the tripod over the point.





6. Use the tape to measure from the center of the point on the ground to the measurement point of the Z-Max.Net (see *Hb* opposite). Later on, you will have to enter the value read on the tape (see point 5. on page 97).
7. If you wish to power up the Z-Max.Net unit from an external power source, connect the power cable supplied (P/N 730477) to the Z-Max.Net power input (marked “PWR”) located on the rear panel. Connect the other end of the cable to the power source using the alligator clips.



Getting the Z-Max.Net Unit Started in Static

1. Press the Power button on the receiver module front panel for 2 seconds until a beep is emitted.
2. Configure the system to perform a static survey. By default, the Z-Max.Net system is configured to perform a static survey. When turned on and once enough satellites are received above 10 degrees of elevation, the receiver automatically begins to collect and store data in a new data file with a data recording interval of 10 seconds. In the event the Z-Max.Net would not be configured to run in static and there is no data logging in progress, do the following to re-configure the Z-Max.Net:
 - Press the Down key until SURVCONF is displayed
 - Press the Enter key
 - Press the Down key and then the Enter key again
 - Press the Down key until STATIC is displayed
 - Press ENTER The screen now displays MODE:STATIC. (The front panel interface is thoroughly described in *Operating Z-Max.Net from its Front Panel on page 123.*)
3. Set the recording interval:
 - Press the Up key. The screen now displays the current value of the recording interval.
 - Press the Enter key. You can now enter the recording interval:
 - Press the Enter key



- Enter the first character of the recording interval using the Up or Down key, then press Enter. Set the second character using the same Up or Down key, etc.
 - After defining the last character, press the Enter key to validate the recording interval. The screen displays the entered interval (e.g. REC INT:20.0s)
4. Enter the Site ID:
- Press the Cancel key to return to SURVCONF
 - Press the Down key until the screen displays SURVEY:STATIC
 - Press the Enter key. SITE:???? is now displayed.
 - Press the Enter key again
 - Enter the first of the four characters making up the Site ID pressing the Up or Down arrow until the desired character is displayed, then press Enter. Set the second character using the same Up or Down key, etc.
 - After defining the last character, press the Enter key to validate the site ID. The screen displays the entered site ID (e.g. SITE ID:0005)
5. Enter the *Hb* height measured earlier with the tape (see point 6. on page 96):
- Press the Up key. The screen displays ANT HT:..
 - Press the Enter key
 - Enter the first character of the antenna height measured previously using the Up or Down key, then press Enter. Set the second character using the same Up or Down key, etc.
 - After defining the last character, press the Enter key to validate the HI. The screen displays the entered HI (e.g. ANT HT:01.5703m)
6. For the “static rover” only, enter the approximate length of the baseline:
- Press the Up key and then enter this length (ESTIMATED BASELINE LEN:xxxxm). This parameter is very important as it will be used by the Z-Max.Net to help you determine the end of data collection.



Starting Data Collection

7. Start raw data logging as follows:

- Return to the root menu and then press the Down key until SESSIONS is displayed
- Press Enter. START SESSION is now displayed.
- Press Enter again. Start Session? is now displayed.
- Press Enter again. DONE is displayed for a few seconds. Data logging is now in progress as indicated on the Data Log LED which should blink green once at the frequency of the data recording interval.

End of Data Collection

8. Return to the SURVEY:STATIC root menu, press Enter, press the Up key twice. The screen should now display the ESTIMATED BASE LINE LEN parameter.
9. Let the Z-Max.Net rover collect data until this parameter goes down to “000 km” (see also page 129 for more detail). You can stop data collection (but always use your own judgement to decide the moment when to stop data collection.)

Remember the amount of data required is dependent on a number of factors including:

- The quality of the satellite geometry (PDOP),
- The number of satellites above the elevation mask,
- Any obstructions between the satellites and the GPS antenna
- The distance (or vector length) between the receivers collecting data simultaneously.

10. To end data collection, just turn off the Z-Max.Net system by pressing the Power button for 2 seconds. When the receiver is powered down the active measurement file is automatically closed.

When the receiver is powered back up a new measurement file will be automatically created.

After data collection is complete, take all Z-Max.Net systems used in the survey to the office and download the data to an office computer as described in *Downloading Field Data to your PC on page 110*. The data is now ready for post-processing using GNSS Solutions.

Running a Kinematic Survey

The kinematic data collection process requires at least two receivers collecting data simultaneously.

One receiver is called the base and must remain stationary throughout the data collection. Typically, the base receiver will occupy a survey point for which the precise position is already known.

Once operational, the base system simply collects and stores raw data from all satellites with line of sight to the GPS antenna (cf. Static survey).

The kinematic base is essentially the same as a static occupation.

The other simultaneously operating GPS receiver(s) during a kinematic survey is (are) designated as the rover(s). The rover unit(s) can move during the survey and are used to position new points relative to the base.

There are two types of kinematic survey supported by the Z-Max.Net system:

- Stop & Go
- Continuous kinematic.

Stop & Go Kinematic

Stop-and-go surveying is best suited for collection of points. During Stop-and-go, the system is centered over a point and collects data for a period of time. The occupation time for stop-and-go will typically be 4 to 8 seconds for a one-second logging interval.

It is highly recommended that a pole with bipod legs be used for Stop-and-go data collection to insure that the antenna is stable during this data collection period.

Once the point occupation is finished the system can be carried to the next survey point and the procedure is repeated.

Continuous Kinematic

Continuous kinematic data collection is suited for collecting bulk points with minimal attributing (terrain modelling) or linear features such as a road centerline.

During continuous kinematic data collection the user never has to stop moving. A point is collected every time the receiver records a data record.

The recording interval for this application would typically be 1-2 seconds, and the accuracy is typically 0.03 to 0.05 meters (0.10-0.15 feet).

The rover system is designed to be carried easily and is mounted entirely to a range pole.

Kinematic data collection has the advantage of high productivity. However there are some trade-offs to be considered. Accuracy is not as good as with GPS static data collection methods (see data sheet for specifications). In addition, field procedures require more planning and care.

During the kinematic data collection, the receiver must maintain lock on at least 5 satellites which are common at both the base and rover stations.

In cases of loss of lock due to obstructions, it is possible that the accuracy of processed results will be degraded if re-initialization is not performed in the field. Therefore, re-initialization in the field after a loss of lock is critical to maintaining survey accuracy (see Initialization below).

Finally, kinematic surveys are most successful when the kinematic base receiver is close to the kinematic rover. Accuracies of GPS-derived positions are distance-dependent. The greater the distance between the GPS receivers, the larger the uncertainty.

In an ideal case, the kinematic base should be on the same project site as the kinematic rover. Kinematic surveys with a separation of more than 10 kilometers (6 miles) between the kinematic base and rover should be avoided. Such a separation makes kinematic initialization more difficult, increasing the chances of poor results.

Base Setup

The base should be set up and started as you would in static (see page 95). The only difference is that you should use a different recording interval (0 to 2 seconds instead of 30 seconds typically in static).

Pole-Mounted Rover

Typically this rover setup is used without a field terminal although using a field terminal in this case is always possible.



1. Connect the system components (power module, GNSS and UHF antenna modules, V-module) as explained on page 19.
2. Mount the Z-Max.Net assembly on the survey pole:
 - Remove the brass adapter from the top of the pole and attach it to the base of the Z-Max.Net assembly.
 - Seat the Z-Max.Net onto the pole.

If no adapter is available, just thread the pole directly on to the base of the receiver.



3. Determine the height of the range pole (see H_r opposite). If you are using a standard pole, this height is given by the pole manufacturer so you don't need to measure it. You will later have to remember this height when setting the rover.
4. Mount the field terminal on its field bracket and then secure the assembly onto the survey pole. The rover is now ready for use.

Backpack-Mounted Rover

The Z-Max.Net backpack is designed to allow users to comfortably carry the unit in the pack while using a range pole to precisely center the GPS antenna over the survey point. The backpack has adjustable shoulder and hip straps, and an adjustable torso bar. The backpack should be properly adjusted for the user.

Typically this rover setup is used with a field terminal as the Z-Max.Net front panel in this case is hidden.

Backpack

1. Connect the system components (power module, V-module) as explained on page 19.
2. Insert the Max RF adapter into the antenna receptacle at the top of the receiver module. Make sure the base of the adapter is oriented so that the flattened area is lined up with the flattened area of the receptacle, and the module can easily be pushed into place. Once in place, twist the threaded collar until the antenna is securely locked in place.
3. Place the receiver onto the backpack and secure the unit with the Velcro strap.
4. Connect the GPS RF cable to the Max RF adapter as shown opposite.





Pole

1. Screw the range pole RF adapter onto the top of the 5/8 inch threaded survey pole or adapter bolt. The range pole RF adapter is exactly the same height as the receiver module **in order to keep the same antenna HI as the Z-Max pole-mounted system.**
2. Insert the void UHF antenna module into the top of the range pole RF adapter (same principle for assembling these elements as in 2.. above).
3. Place the Z-Max.Net backpack on your back and adjust the straps so that you feel comfortable to carry the system. Be careful not to damage the end of the RF cable when doing this.
4. Connect the free end of the GPS RF cable coming from the backpack to the range pole RF adapter.
5. Determine the height of the range pole (see *Hr* opposite). If you are using a standard pole, this height is given by the pole manufacturer so you don't need to measure it. You will later have to remember this height when setting the rover.
6. Mount the field terminal on its field bracket and then secure the assembly onto the survey pole. The rover is now ready for use.

Getting the Z-Max.Net Unit Started in Kinematic



1. Press the Power button on the receiver module front panel for 2 seconds until a beep is emitted.
2. Stop the data recording session that automatically starts at power-up:
 - Press the Down key until SESSIONS is displayed
 - Press the Enter key. STOP SESSION is now displayed
 - Press Enter again. Stop session? is now prompted.
 - Press Enter to confirm that you want to stop the data recording session. DONE is temporarily displayed to confirm that the session has been stopped.
 - Press the Up key to return to the root menu.
3. Configure the system to perform a kinematic survey:
 - Press the Down key until SURVCONF is displayed
 - Press the Enter key
 - Press the Down key until MODE:... is displayed
 - Press the Enter key
 - Press the Down key until KINEMATIC is displayed
 - Press Enter. The screen now displays MODE:KINEMATIC.
4. Set the recording interval:
 - Press the Down key until REC INT is displayed. You can now enter the recording interval you would like to use:
 - Press the Enter key
 - Enter the first character of the recording interval using the Up or Down key, then press Enter. Set the second character using the same Up or Down key, etc.
 - After defining the last character, press the Enter key to validate the recording interval. The screen displays the entered interval (e.g. "REC INT:002.0s").
5. If you are preparing a Stop & Go kinematic survey, you can define the occupation time on each point. This time is expressed in number of epochs. An epoch represents one acquisition of GPS data. To enter a value for the Epoch Counter, do the following just after entering the recording interval:

- Press the Down key until EPOCH COUNTER is displayed. You can now enter the recording interval:
- Press the Enter key
- Enter the first character of the recording interval using the Up or Down key, then press Enter. Set the second character using the same Up or Down key, etc.
- After defining the last character, press the Enter key to validate the epoch counter. The screen displays the entered value (e.g. "EPOCH COUNTER:008").

Epoch Counter

*Should be set to "000" for
Continuous kinematic
Should be different from
"000" for Stop & Go*

The Epoch Counter will count the time that each point is occupied in the kinematic survey. When the Site ID is entered, the epoch counter will automatically decrement with each epoch of GPS measurements recorded. When the counter gets to 0, an audible alarm will be generated to indicate that data collection at that point is complete. You will then have to move to the next point, confirm or change the prompted new Site ID (previous site ID + 1), and the Epoch Counter will reset and again begin to decrement.

Note that the Epoch Counter parameter is meaningless in continuous kinematic (keep it to "000" in this case).

6. Enter the *Hr* height measured earlier:
 - Press the Cancel key to return to SURVCONF
 - Press the Down key until the screen displays SURVEY:KINEMATIC
 - Press the Enter key
 - Press the Up key. The screen displays ANT HT:..
 - Press the Enter key. Enter the first character of the antenna height measured previously using the Up or Down key, then press Enter. Set the second character using the same Up or Down key, etc.
 - After defining the last character, press the Enter key to validate the HI. The screen displays the entered HI (e.g. ANT HT:02.1240m)

Other parameters can be set such as Elevation Mask and Min SV. For more information on these parameters, please refer to *SURVEY: KINEMATIC on page 131*.

7. Enter the Site ID:

- Press the Down key. SITE:???? is now displayed.
- Press the Enter key again
- Enter the first of the four characters making up the Site ID pressing the Up or Down arrow until the desired character is displayed, then press Enter. Set the second character using the same Up or Down key, etc.
- After defining the last character, press the Enter key to validate the site ID. The screen displays the entered site ID (e.g. "SITE ID:0005"). Note that you won't be able to change the Site ID as long as you select another survey mode. This means the entered Site ID will be associated with the entire set of kinematic data you will collect during the recording session. It also means that once a valid Site ID has been entered, you will later have to set it *before* selecting the kinematic mode.

Starting Data Collection

8. Start raw data logging as follows:

- Return to the root menu and then press the Down key until SESSIONS is displayed
- Press Enter. START SESSION is now displayed.
- Press Enter again. Start Session? is now displayed.
- Press Enter again. DONE is displayed for a few seconds.

At this stage you can start your continuous kinematic survey. Don't forget the initialization requirement (see *Initialization Process on page 251*). A single site ID will be associated with the trajectory data collected during the recording session.

For a stop & go survey, you have to go back to the display of the Site ID to control your work:

- Keep still on the first point to be surveyed
- From the root menu, press the Down key until SURVEY:KINEMATIC is displayed and then press Enter
- Press Enter again to edit the Site ID
- After you have validated the Site ID, the screen displays LOG#:xxxx where xxxx is the Epoch Counter value. This value starts decrementing.
- Keep still on the point until the end of the count-down. The screen then displays a new Site ID (previous Site ID+1) followed with a question mark.
- Walk to the next point and resume the previous three steps and so on.

End of Data Collection

9. When you are done with your survey, stop the data recording session as follows:

- Press the Down key until SESSIONS is displayed
- Press the Enter key. STOP SESSION is now displayed
- Press Enter again. Stop session? is now prompted.
- Press Enter to confirm that you want to stop the data recording session. DONE is temporarily displayed to confirm that the session has been stopped.

Running a Post-processing Survey Using FAST Survey

Static Mode



Tap on the Surv tab and select the Log Static Data function. If no data logging is in progress, a menu is then displayed on the handheld computer's screen (see screen on the left). If data logging is already in progress, a message is displayed prompting you to stop or continue data logging. Tap Yes to stop data logging in progress.

Tap Start File and then enter the logging parameters (elevation mask, default=5°; data logging interval, from 0.1 to 999 seconds).

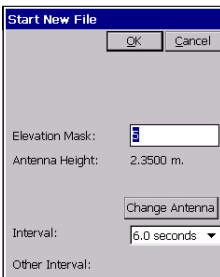

Check that the antenna height value is correct, otherwise change it by tapping on the Change Antenna button (see screen opposite).

Click OK to start a new data logging sequence.

To stop logging data, tap on the Close File button, which is now active.

Kinematic Mode

Start data logging as explained previously in Static mode. Once data logging has begun, you can go to the point you want to log and stay stationary on that point ("Stop&Go" method). The occupation time on each point can be preset or not.

Once the receiver is placed over the point, select Tag New Site from the menu and enter the characteristics of the point (see screen opposite). The Stop Logging parameter can be set manually or to a given time (typically 0.2 minute with Z-Max.Net).

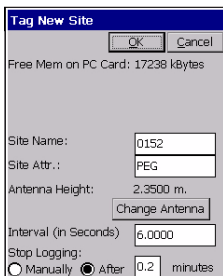

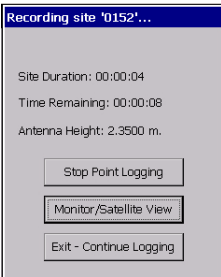

Tap OK. A new screen appears showing the time spent logging data on the point (occupation time).

If you have previously checked **Manually** as the Stop Logging option, select **Stop Point Logging** before moving away from the point. FAST Survey will then ask you to validate the data logged on that point. The time spent logging raw data on a point (occupation time) depends on the logging interval used. With a one-second logging interval, an occupation time of 10 seconds (0.2 minutes) will allow you to achieve centimeter accuracies.

When moving from point to point, take care to keep the receiver in vertical position to avoid satellite loss. Accuracy will depend on your ability to maintain good working conditions thus letting the system log raw data without any disruption.

When you are done with your job, click on the Close File button to close the file being logged.

File Management

Use the File Manager button on the Log Static Data menu (Surv tab) to list and manage the files stored on the receiver's SD card. See figure below.

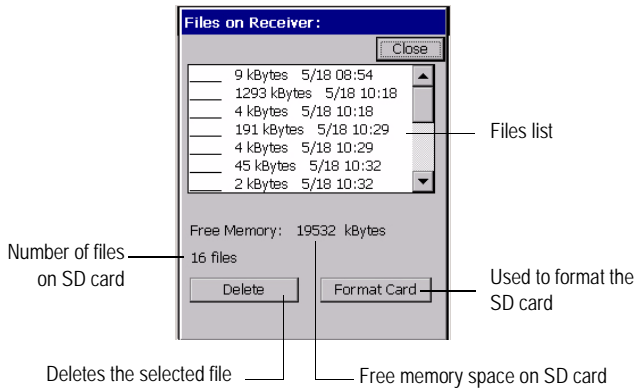

Downloading Field Data to your PC

Using A Local SD Card Reader

The easiest and fastest way to download your field data is to use the card reader attached to the office PC. This procedure is described in the present section. It is assumed that GNSS Solutions has already been installed on your PC.

Back in your office, do the following to download your field data.



After downloading your field data, do not forget to re-insert the SD card into the Z-Max.Net before taking it back to the field!

1. On the Z-Max.Net:

- Remove the SD card from the Z-Max.Net
- Insert the SD Card in your local SD card reader.

2. On the office computer:

- From the Windows task bar, select Start>Programs>GNSS Solutions>Tools>Download. This opens the Download window.
- Double-click  in the right side of this window to change to the parent directory on your PC and then open the folder where you would like to download the field data
- Click on the drive combo box (see below) in the left-hand pane and select the letter corresponding to the local SD card reader (example: SD card reader is "F:").

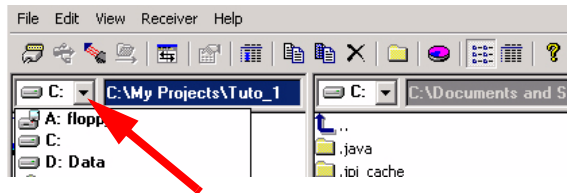

The left side of the Download window then lists the files present on the SD card.

- In the left-hand pane, select the files you want to download. If necessary, hold down the Ctrl key to make a multiple selection.

Files resulting from the downloading of an observation file are named as follows:

*X<Downloadedfilename>
where prefix X = "E" for
Ephemeris Data, "B" for
Position Data, "D" for
GPS Raw Data and "W"
for SBAS Data.*

- Press the **F5** key. A Copying file dialog appears during data transfer.

After the transfer is complete, notice in the right side of the Download window that each downloaded file has been split into different files named with a prefix as explained opposite.

- Close the Download window.

3. Repeat the previous two steps for each of the Z-Max.Net units (base, etc.) involved in the project to download their respective files to the same project folder on your office computer.

Using Serial Connection to Z-Max.Net

If you don't have a card reader, you can download your field data directly from Z-Max.Net via a USB or RS 232 link.

The USB procedure is described in the present section. It is assumed that GNSS Solutions has already been installed on your computer and the Z-Max.Net unit is off.

1. Connect the USB cable (P/N 110949) between Z.Max.Net and your office computer. To access the USB connector on the Z-Max.Net, open the door on the front panel.
2. Make sure there is nothing connected to serial port A on Z-Max.Net.
3. Make sure Microsoft Active Sync is inactive on your office computer. In the Active Sync connection settings dialog box, disable USB connection with your computer.
4. Power up Z-Max.Net. The first time you establish this USB connection, the office computer will install the required USB driver to be able to communicate with the Z-Max.Net unit.

5. On your office computer:
 - From the Windows task bar, select Start>Programs>GNSS Solutions>Tools>Download. This opens the Download window.
 - Double-click  in the right side of this window to change to the parent directory on your PC and then open the folder where you would like to download the field data
 - From the Download menu bar, select File>Connect>Receiver>Connect via USB....
 - Select the USB device the computer should use to connect to Z-Max.Net (Z-Max USB device #) and click OK.
 - Wait until Download lists the raw data files in the left part of the Download window
 - In the left-hand pane, select the files you want to download. If necessary, hold down the Ctrl key to make a multiple selection.
 - Press the **F5** key. A Copying file dialog appears during data transfer.

After the transfer is complete, notice in the right side of the Download window that each downloaded file has been split into several files with different prefixes.
 - Close the Download window.

Post-Processing Field Data

1. On your office computer, launch GNSS Solutions
2. Click Create a New Project, enter a project name and then click OK.
3. Click Import Raw Data from Files.
4. Browse your computer to change to the folder containing the data files you have downloaded earlier.
5. Select the files you want to import and click Open.

The Importing GPS Data dialog lists the files you want to import (top). Each row describes one of these files (file-name, associated Site ID, etc.)

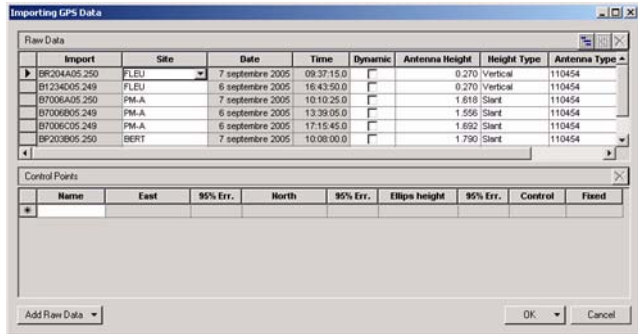

6. At the bottom of the window, define which of the sites is the control point (base) and enter or check its known coordinates. You can also fix the control point if necessary by selecting one of the options available in the Fixed column. If you select <Blank>, the point won't be fixed.
7. Click OK>To Import to import the data into the project. Depending on the type of survey, you can go even faster by running, in one operation, the Import, Process and Adjust functions.

For more information on GNSS Solutions, please refer to the *GNSS Solutions Reference Manual*.

5. FAST Survey Software

Introduction

This chapter just gives an overview of FAST Survey. For a detailed description of this software, please refer to the *FAST Survey Reference Manual*.

MENU Screen

This screen shows 5 different tabs giving access to the main functions of FAST Survey. Although all function titles on each tab are self-explanatory, a more detailed definition of these functions is provided in the next pages.

The right arrow located in the upper-right corner of the MENU screen allows you to access the MAP screen (see page 121).

File tab

Job: Allows you to select an existing coordinate file for your job or to create a new coordinate file. A job consists of real-time data only. Several types of files are associated with a job (.crd, .rw5, .inf, etc.).

Job Settings: Allows you to set configuration options for data collection

List Points: Lists all of the points in the current coordinate file (.crd)

JOB:Di..415		MAP
Surv	COGO	Road
File		Equip
1 Job	6 Data Transfer	
2 Job Settings	7 Import/Export ASCII	
3 List Points	8 Delete File	
4 Configure Reading	9 Add Job Notes	
5 Feature Code List	0 Exit	

Configure Reading: Allows you to select settings and preferences that apply to observations taken in the field

Feature Code List: Used to define feature code lists

Data Transfer: Prepares FAST Survey for transferring data to and from a PC

Import/Export ASCII: Allows you to import an ASCII file to job data or export job data to an ASCII file

Delete File: Allows you to remove any existing file from any directory to free up memory on the handheld computer

Add Job Notes: Allows you to enter job notes as ASCII text

Exit: Will exit the FAST Survey program.

Equip tab

Instrument: Allows you to set the equipment type that you will be using (Z-Max, Z-Xtreme)

Configure Base: Sets up the base antenna and record the correct antenna height, the antenna type and the methods used for localizing

Configure Rover: Used to set the rover receiver to the correct parameters and to instruct the receiver that it is a rover

Receiver Utilities: Resets and/or troubleshoots the GPS receiver. Sets radio/GSM parameters.

Localization: Allows you to align on a local coordinate system

Monitor/Skyplot: Allows you to review position and quality of data

Tolerances: Allows you to set operating tolerances

Comm Setup: Allows you to specify communication parameters for the handheld computer to be able to communicate with the GPS receiver (serial cable, Bluetooth)

About FAST Survey: Allows you to view information about FAST Survey and change your registration.



Surv tab

Store Points: Principal data collection routine (gives access to the Point Logging function)

Stakeout Points: Allows you to stakeout to a selected point by guiding you to the point with a series of commands and directions (Point Stakeout function)

Stakeout Line/Arc: Opens a secondary dialog where you can choose between

Stake Line, Stake Centerline, Stake Arc (3 points) and Stake Arc (PC, R, PT)

Offset Stakeout: Will stake out up to 2 user defined horizontal offsets to a centerline at any station as well as an unlimited number of offsets per station if you are using a predefined Cutsheet Station and Offset List

Elevation Difference: Will report a cut/fill in comparison with your current location to a design surface at any location within a project

Auto by Interval: Allows you to acquire and store data at a set interval value of either distance or time (Point Logging performed at regular intervals of time or distance)

Log Static Data: Allows you to log static raw data to the data card for use with GNSS Studio Post Processing software.



COGO tab

Keyboard Input: Allows you to manually enter or edit coordinates in the current job file or the current control file

Inverse: Reports the bearing and horizontal distance between any two user specified points that are contained within the current job

Areas: Calculates the area of a closed figure that is defined internally by user-entered point numbers contained within the current job or by a polyline picked from the screen

Intersections: Allows for the calculation and storing of points based upon standard surveying practices of Bearing-Bearing, Bearing-Distance, or Distance-Distance Intersection calculations

Point Projection: Allows you to calculate the station and offset of any entered or surveyed point relative to a known centerline or baseline

Station Store: A pure calculation routine that will create point numbers based on a station and offset from an alignment

Translate, Rotate, Scale: Allows you to translate, rotate, and/or scale points in the current job

Calculator: Eliminates the need to carry a separate calculator in the field. The calculator can be used to do scientific computations, standard calculations, conversions, triangle calculations including angles, and curve calculations.

Process Raw File: Creates a raw file (.RW5) that contains various lines of survey data similar to a surveyor's field book

Point in Direction: Allows for manual entry of angles and distances and calculates sideshots or traverses from a known occupied point.



Road tab

Input/Edit Centerln: Used to enter new centerlines and recall/edit existing centerline files

Draw Centerline: Draws the selected centerline on the screen

Input/Edit Profile: Allows field entry of vertical alignment files for roads, sewers and other types of alignments

Draw Profile: Draws the selected profile on the screen

Input/Edit Template: Used to enter templates, for roads, levees, ditches and other such earthwork

Draw Template: Draws the selected template on the screen

Slope Staking: Used to calculate and stake out the location of the “catch point” where fill slopes or cut slopes contact the original ground

Cross Section Survey: Collects as-built cross sections of roads or other alignments and stores them as points

Road Utilities: Converts centerlines, profiles and cross sections from other formats to the formats used by FAST Survey

Template Stakeout: Designed to stakeout specific stations and offsets along a centerline.





This icon, located at the top of the screen, indicates the type of survey equipment selected (GPS or Conventional). Clicking on this icon allows you to access the **Instrument** window (see opposite) in which you may either save the current FAST Survey configuration or recall a previous one. Clicking on the **Current** tab allows you to identify the survey equipment (Type, firmware version, etc.).

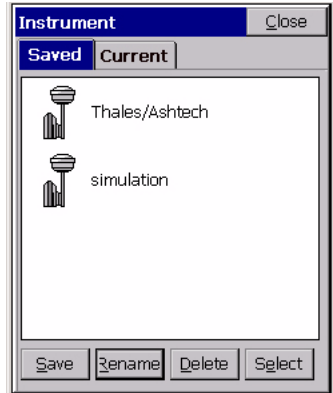

MAP Screen

This screen provides a graphic representation of your job. It also shows the points you have to stake, the points that have already been logged and receiver status data. The right arrow located in the upper-right corner of the screen allows you to return to the MENU screen.

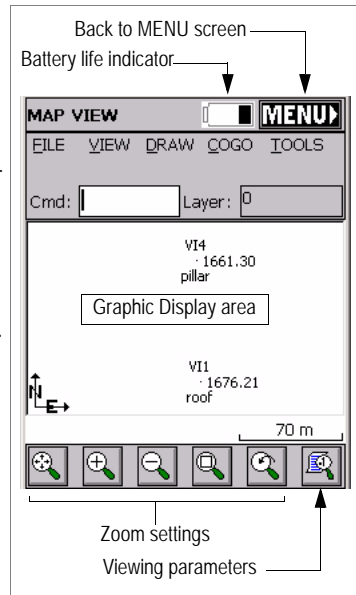

Using the Internal GPS Antenna

Follow the procedure below to use the internal antenna of the MobileMapper CE as the GNSS signal source for FAST Survey:

- Run FAST Survey
- On the Equip tab, tap Instrument
- In the Instrument field, select “NMEA GPS receiver”
- Tap OK. This automatically opens the Comm Setup dialog.
- Make the following settings:
 - Port Number: COM2
 - Baud Rate: 57600
 - Parity: None
 - Char Length: 8
 - Stop Bits: 1
- Tap OK to validate the new settings and close the dialog.
- Still on the Equip tab, tap Monitor Skyplot to check that GNSS signals are now received and processed in FAST Survey.

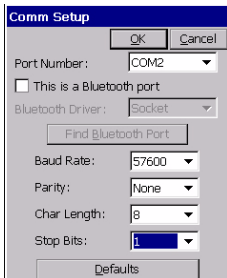

6. Operating Z-Max.Net from its Front Panel

Introduction

The front panel user interface allows you to monitor and control many receiver parameters and functions.

The display is an 8-character scrolling alphanumeric LED screen and four control keys that allow you to:

- Set receiver parameters
- Configure the receiver to perform different types of surveys
- Monitor system status during operation.

All these functions are covered in great detail in this chapter.

The front panel user interface is also used to show equipment status messages and warnings that are automatically generated by the Z-Max.Net unit.



Control Keys

The front panel user interface is accessed using the four control keys located on the front panel of the receiver module:

- The Up and Down arrow keys are yellow
- The Enter key is green
- The Cancel key is red.

The control keys provide access to all the functionality of the display including moving within the menu tree, selecting available parameters, and entering letters or numbers like a keypad. The keys will work differently depending upon whether the screen is in *Display mode* or *Edit mode*.



Display Mode

In Display mode, the screen does not contain any parameters that are changeable.

- The Up/down keys are used to scroll forward and backward within a submenu level
- The Enter/cancel keys are used to move to a lower level submenu or up to a higher level.

Key	Operation
Up (yellow)	Scrolls menu (at same level) forward
Down (yellow)	Scrolls menu (at same level) backward
Enter (green)	Selects and moves down to next level or enters Edit mode
Cancel (red)	Returns to upper level

Edit Mode

In Edit mode, the keys are used either to scroll through and select from a parameter list, or as a keypad to enter letters or numbers into a parameter field that requires either alpha or numeric input.

Key	Operation
Up (yellow)	Data entry context: Scrolls forward through characters Parameter list context: Scrolls forward Fast scrolling if held depressed for 3 seconds
Down (yellow)	Data entry context: Scrolls backward through characters Parameter list context: Scrolls backward Fast scrolling if held depressed for 3 seconds
Enter (green)	Parameter list context: Selects parameter Data entry context: Accepts character and moves to next space or quits Edit mode
Cancel (red)	Data entry context: Deletes last edited character, stays in Edit mode Parameter list context: Moves from Edit mode to Display mode without selecting the parameter.



Using Control Keys

For example, the LED screen is initially at the top level of the menu tree and is in Display mode.

- Pressing the Up key will scroll through the submenus SYSINFO, SURVEY:<currently selected mode>, SURVCONF, SESSIONS, SETTINGS, and COM OPTN
- Pressing the Down key will scroll through the same submenus, but backwards.
- If you stop when the display reads "SETTINGS", you are now at the entry point for the SETTINGS submenu:
 - Press the Enter key and move down one level into the SETTINGS submenu.
 - Pressing the Up key will scroll through the available functions in the SETTINGS submenus: MEMORY RESET, RESET TO FACTORY DEFAULTS, etc.
 - Holding the Up or Down keys for 3 seconds will initiate fast scrolling. Use fast scrolling when you have a large list of items to scroll through.
 - To perform a function in the SETTINGS submenu, press the Enter key.
 - To return to the top level, press the Cancel key.

Disabling Beep

By default, the receiver will emit a beep every time a control key is pressed. To disable this beep:

- Go to the SETTINGS menu
- Scroll to the BEEP submenu
- Select OFF and press Enter.

Be aware that the beep is used as an audible alert for many types of messages and warnings. Disabling the BEEP will disable the audible warnings as well.

Waking Up the Display

Although the Z-Max.Net is powered on, the display may not be active. If no keys are pressed for more than 20 seconds, the front panel user interface will shut down to save power. Press any control key to restore the display to its original state before it shut down.

Automatic Data Recording

When GPS measurements are being collected or when surveys are being performed, data is automatically stored in the Z-Max.Net memory. Therefore, there are no additional steps required to save information collected during a survey.

Saving Operating Parameters

Operational parameters control how the Z-Max.Net operates and collects data.

Operational parameters, including recording interval and antenna height, entered or modified by the user with the front panel user interface, will not automatically be saved to memory after a power cycle unless they are explicitly saved.

The operational parameters of the Z-Max.Net are saved as a group in one step:

- Go to the **SETTINGS** submenu
- Select the **SAVE** option to save operational parameters to memory.

If the operational parameters of the Z-Max.Net are not explicitly saved, the unit will revert to factory defaults or the last saved parameter set after a power cycle.

Front Panel Interface Function Diagram

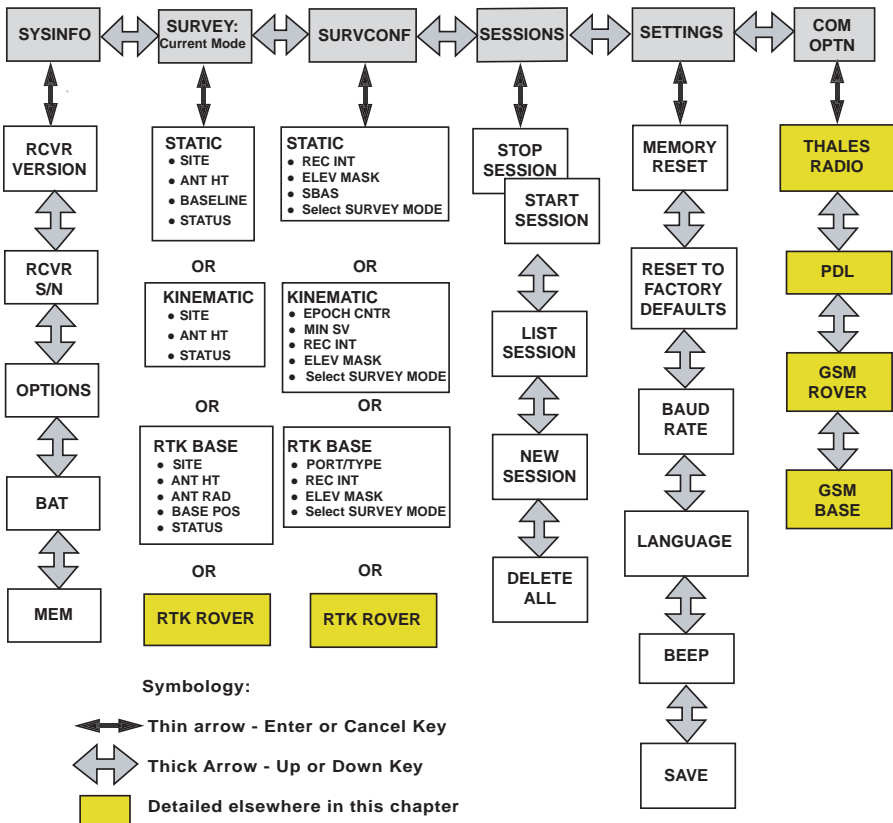

SYSINFO Menu (System Information)

- **Receiver Software Version Number (VER: ****)**
Version of the firmware installed within the receiver.
- **Receiver Serial Number (S/N: *****)**
Serial number of the receiver.
- **Firmware Options (Options: *****)**
A string that denotes the options enabled in the receiver. See *Firmware Options on page 268* for an explanation of the option codes.
- **Power Status (BAT:** min)**
Indicates the amount of power left in the power module. This value is expressed in minutes of remaining time left based upon the current rate of power consumption. If the power module is not connected, it will show 0 minutes. Power status does not apply to the external battery.
- **Memory Status (MEM: ** %)**
Displays the percentage of memory left on the SD memory card. Occasionally after a power cycle, the receiver file system will slow mount. This process takes several minutes and the field MEM will display xx%.

NOTE: The firmware version number, the receiver serial number and the firmware options are needed when contacting Technical Support.

SURVEY:... Menu (Survey Parameters and Status)

The SURVEY: <currently selected mode> menu is used to set site-specific survey parameters, execute surveys and view survey status parameters.

This menu tree is mode-dependent, meaning that the parameters displayed in this submenu are dependent on the type or mode of survey selected in the Survey Configuration (SURVCONF) screen. The default survey mode is STATIC. If a different survey mode is desired, enter the SURVCONF menu to select the desired survey mode and enter the initial parameters for that mode before returning to this menu and setting parameters.

There are four possible modes:

- Static (default)
- Kinematic
- RTK Base
- RTK Rover

To enter this menu from the top level of the menu tree, use the Up/Down keys until SURVEY:... is displayed, then press the Enter key. The parameters displayed and available will depend upon which survey mode has been set in the SURVCONF menu. Use the Up/Down keys to scroll through the following parameters.

SURVEY:STATIC

If “STATIC” has been selected in SURVCONF, the parameters displayed in this menu are:

- **Site ID** (SITE: ****)

Displays and sets the 4-character Site ID. To change the Site ID, press the Enter key and use the control keys to enter the desired site name.

- **Antenna Height** (ANT HT: **.**** m)

Displays and sets the height of the antenna above the survey mark. To change the antenna height, press the Enter key and use the control keys to enter the height. Valid range is from 0.00 - 64.0000 meters.

- **Estimated Baseline Length** (ESTIMATED BASELINE LEN: *** km)

Enter the distance to the base in this field. After starting the data recording session and as data is being collected, this parameter will count down. When “000km” is displayed, this means enough data has been collected for the survey. Note that another parameter, called “Observation Timer” (see page 130), gives an indication of when enough data has been collected. Unlike “Estimated baseline length”, which decreases as data is being collected, “Observation Timer” increases with time, as more data is being collected.

- **Survey Status (STATUS)**

This is the entry point to the submenu that displays the static survey status parameters. To enter this submenu, press the Enter key and the following parameters are accessible:

- **Current Position**

(LAT: N/S ** ** * . ***** LON: E/W * * * * * . ***** ALT: ***** . *** m)

This field displays the computed latitude and longitude in degrees, minutes, and seconds, and the computed height above the ellipsoid in meters. The displayed position is either an autonomous or code-phase differential position.

- **PDOP (PDOP: ** .*)**

Displays the PDOP value for the current satellite constellation.

- **Number of Satellites Used (#USED: **)**

Displays the number of satellites used in the position computation. If the elevation mask is the same as the position elevation mask, then this is also the number of satellites being recorded on the data card.

- **Time (CNT/GPS/UTC: ** .** .**)**

This screen displays the current time and will show one of three types of time. CNT is the time since power up and is displayed until the receiver first locks onto a satellite. GPS is GPS time and is displayed between locking onto a satellite and until receiving UTC time corrections. UTC is UTC time.

- **Observation Timer (OT: ***km)**

At any given time during the static survey, this parameter indicates the vector length, in km, that GNSS Solutions could determine considering the amount of data collected at that time since the beginning of the data recording session.

- **Time Elapsed (TE: ** .**)**

This parameter indicates the time elapsed since the beginning of the data recording session (hh:mm format).

SURVEY: KINEMATIC

If “KINEMATIC” has been selected in SURVCONF, the parameters displayed in this menu are:

- **Site ID (SITE: ****)**
Displays and sets the 4-character Site ID. To change the Site ID, press the Enter key and use the control keys to enter the desired site name.
- **Antenna Height (ANT HT: **.**** m)**
Displays and sets the height of the antenna above the survey mark. To change the antenna height, press the Enter key and use the control keys to enter the height. Valid range is from 0.00 - 64.0000 meters.
- **Survey Status (STATUS)**
This is the entry point to the submenu that displays the kinematic survey status parameters. To enter this submenu, press the Enter key and the following parameters are accessible:
 - **Current Position**
(LAT: N/S **.*.***** LON:E/W ***.*.***** ALT: *****.*** m)
This field displays the computed latitude and longitude in degrees, minutes, and seconds, and the computed height above the ellipsoid in meters.
 - **PDOP (PDOP: **.*)**
Displays the PDOP value for the current satellite constellation.
 - **Number of Satellites Used (#USED: **.*)**
Displays the number of satellites used in the position computation. If the elevation mask is the same as the position elevation mask, then this is also the number of satellites being recorded on the data card.
 - **Time (CNT/GPS/UTC: **.**.*)**
This screen displays the current time and will show one of three types of time. CNT is the time since power up and is displayed until the receiver first locks onto a satellite. GPS is GPS time and is displayed between locking onto a satellite and until receiving UTC time corrections. UTC is UTC time.

SURVEY: RTK BASE

If “RTK BASE” has been selected in SURVCONF, the parameters displayed in this menu are:

- **Site ID** (SITE: ****)
Displays and sets the 4-character Site ID. To change the Site ID, press the Enter key and use the control keys to enter the desired site name.
- **Antenna Height** (ANT HT: **.**** m)
Displays and sets the height of the antenna above the survey mark. To change the antenna height, press the Enter key and use the control keys to enter the height. Valid range is from 0.00 - 64.0000 meters.
- **Antenna Radius** (ANT RAD: *.**** m)
Displays and sets the radius of the antenna. To change this parameter, press the Enter key and use the control keys to enter the radius . Valid range is from 0.00 - 9.9999 meters.
- **Entered Base Station Position** (BASE POS)
Entry point to the submenu that allows you to enter the known accurate base station position. To enter this submenu, press the Enter key. The following fields are now accessible:
 - **Latitude** (LAT: N/S dd mm.mmmmm)
To enter the base station latitude, press Enter and use the control keys to enter the latitude in degrees and decimal minutes.
 - **Longitude** (LON:E/W ddd mm mmmmm)
To enter the base station longitude, press Enter and use the control keys to enter the latitude in degrees and decimal minutes.
 - **Ellipsoidal Height** (ALT: *****. ** m)
To enter the base station height, press Enter and use the control keys to enter the ellipsoidal height in meters.

- **Set to current position (HERE)**

HERE will set the base station position to the current computed position. To set this position, press Enter. The query "Set Current Position to Base?" appears. Press Enter to confirm or Cancel to cancel.

- **Survey Status (STATUS)**

This is the entry point to the submenu that displays the status parameters current position, PDOP, number of satellites, and time. To enter this submenu, press the Enter key and the following parameters are accessible:

- **Current Position**

(LAT: N/S *** **.* **** LON:E/W *** **.* **** ALT: ****.* ** m)

This field displays the computed latitude and longitude in degrees, minutes, and seconds, and the computed ellipsoidal height meters. The displayed position is either an autonomous or code phase differential position.

- **PDOP (PDOP: **.*)**

Displays the PDOP value for the current satellite constellation.

- **Number of Satellites Used (#USED: **.*)**

Displays the number of satellites used in the position computation. If the elevation mask is the same as the position elevation mask, then this is also the number of satellites being recorded on the data card.

- **Time (CNT/GPS/UTC: **.**.*)**

Displays the current time and will show one of three types of time. CNT is the time since power up and is displayed until the receiver first locks onto a satellite. GPS is GPS time and is displayed between locking onto a satellite and until receiving UTC time corrections. UTC is UTC time.

SURVEY:RTK ROVER

If “RTK ROVER” has been selected in SURVCONF, the parameters available from this menu are illustrated in the diagram below:

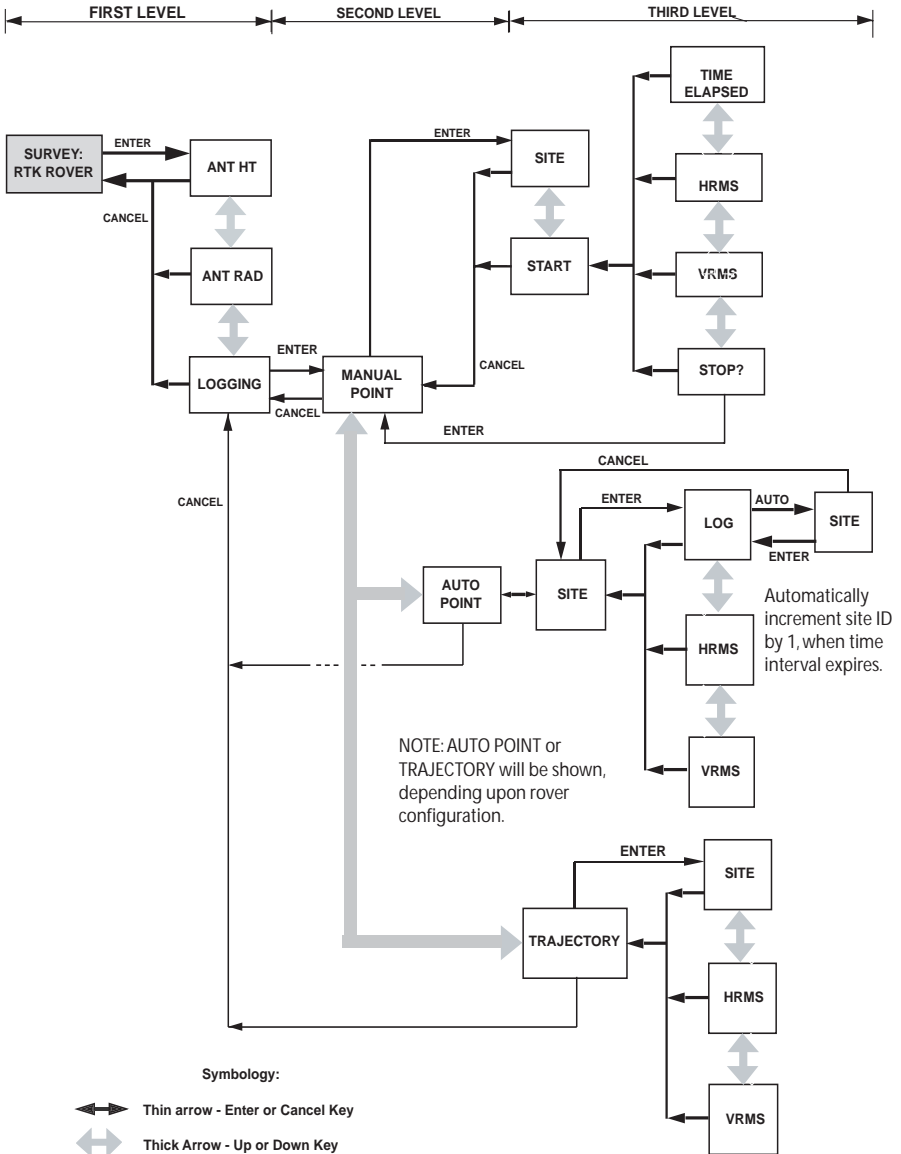

FIRST LEVEL: Antenna-Related Parameters.

- **Antenna Height** (ANT HT: **.**** m)
Displays and sets the height of the antenna above the survey mark in meters. Valid range is from 0.00-64.0000 meters. To change this parameter, press the Enter key. The default is 0.0 meters.
- **Antenna Radius** (ANT RAD: *.**** m)
Displays and sets the radius of the antenna in meters. Valid range is from 0.00-9.9999 meters. To change this parameter, press the Enter key.
- **Entry to Logging submenu** (LOGGING)
Entry point to the second level of submenus. Press the Enter key to reach the 2nd level submenu.

SECOND LEVEL: Manual/Auto/Trajecto.

The second level allows you to select:

- MANUAL or AUTO POINT if the Auto Point option was selected as the LOG TYPE in the SURVCONF menu
- MANUAL or TRAJECTORY if the Trajectory option was selected as the LOG TYPE in the SURVCONF menu.

Selecting one of these options will take you automatically to the third level. To enter the third level, use the Up/Down control keys to select the desired RTK logging type and press Enter.

- **Manual Logging** (MANUAL POINT)
Entry point to the submenus to set manual logging parameters and to execute a Manual Point RTK survey. In a Manual Point survey, the user sets the site name and monitors the elapsed time to determine when to end the site occupation. To enter this level, press the Enter key.

- **Automatic Logging (AUTO POINT)**

Entry point to the submenus to set automatic logging parameters and to execute an AUTO POINT RTK survey. In an AUTO POINT survey, the user sets an initial site name and a “time to stay” parameter in the Survey Configuration menu (SURVCONF). The receiver will collect data on each point based on the “time to stay” parameter and automatically increments the Site ID by 1 at the end of the occupation. To enter this level, press the Enter key.

NOTE: The Site ID will automatically increment only if the last character is numeric.

- **Trajectory Logging (TRAJECTORY)**

Entry point to the submenus to set trajectory logging parameters and to execute a TRAJECTORY RTK survey. In Trajectory logging, the receiver will compute RTK positions each time an interval of a certain distance has been traversed. The Site ID will automatically increment each time RTK data is logged to the receiver. The Distance Interval parameter is set in the Survey Configuration menu (SURVCONF).

NOTE: The Site ID will automatically increment only if the last character is numeric.

THIRD LEVEL.

The third level parameters allow you to set survey parameters, execute the survey, and monitor accuracy for the type of data logging selected in level 2. Only the parameters applicable to that logging type will be displayed. The possible data logging modes are: AUTO POINT, MANUAL POINT, and TRAJECTORY.

MANUAL POINT

- **Site ID** (SITE: ****)

Displays and sets the 4-character Site ID. To change the Site ID, press the Enter key and use the control keys to enter the desired site name.

- **Start Logging** (START)

Initiates data logging at the site entered in the above Site ID field. Also, the entry point to monitor accuracy parameters and to stop data logging. Press the Enter key to start data logging. The following parameters will be available by using the Up/Down keys:

- **Time Elapsed** (TE: **s)

Displays the amount of time in seconds elapsed since data logging began. The field will display up to 9999 seconds of data logging. This field will not increment if no SD card is inserted.

- **HRMS** (HRMS: *.*m)

Displays the horizontal RMS value (in meters) computed during data logging. RMS is an estimate of the 1-sigma position accuracy. This field will display up to 99.999 meters.

- **VRMS** (VRMS: *.*m)

Displays the vertical RMS value (in meters) computed during data logging. RMS is an estimate of the 1-sigma position accuracy. This field will display up to 99.999 meters.

- **Stop Data Logging** (STOP?)

Press the Enter key to stop manual data logging. The query "Stop data logging?" will appear. Press Enter to confirm or Cancel to cancel. If data logging is stopped, the display will jump back to level 2.

AUTO POINT

- **Site ID** (SITE: ****)

Displays the current setting of the 4-character Site ID. To change the Site ID and begin data logging, press the Enter key and use the control keys to enter the Site ID.

Once the Site ID is entered, data will automatically log for the duration of the Time To Stay field set in the SURVCONF menu. Data will only be logged if the receiver is computing “fixed” RTK positions (the RTK SOL LED is blinking green). While logging is in progress, data can be monitored with the LOG, HRMS, and VRMS parameters described below.

When logging at this site is complete, the Site ID field will automatically increment by 1 (if the last character is numeric) and display the new Site ID. Data logging resumes when the Enter key is pressed.

- **Data Logged** (LOG: **s)

Displays the amount of data logged in seconds. When this value reaches the 'Time To Stay' value set in the SURVCONF submenu, the incremented Site ID will be displayed. This field will not increment if no SD card is inserted.

- **HRMS** (HRMS: *.***m)

Displays the horizontal RMS value (in meters) computed during data logging. RMS is an estimate of the 1-sigma position accuracy. This field will display up to 99.999 meters.

- **VRMS** (VRMS: *.***m)

Displays the vertical RMS value (in meters) computed during data logging. RMS is an estimate of the 1-sigma position accuracy. This field will display up to 99.999 meters.

TRAJECTORY

- **Site ID** (SITE: ****)

Displays and sets the 4-character Site ID. To log data, press Enter and input a Site ID. Data will be collected at every interval equal to the Distance Interval parameter set in the Survey Configuration (SURVCONF) submenu. If the last character of the Site ID is numeric, the Site ID will increment each time data is logged to the receiver.

- **HRMS** (HRMS: *.*** m)

Displays the horizontal RMS in meters during data logging. RMS is an estimate of the 1-sigma position accuracy.

- **VRMS** (VRMS: *.*** m)

Displays the vertical RMS in meters during data logging. RMS is an estimate of the 1-sigma position accuracy.

SURVCONF Menu

In the SURVCONF menu, you select the desired survey mode and set initial survey parameters. There are four possible survey modes:

- Static
- Kinematic
- RTK Base
- RTK Rover

To select a survey mode from the top level, press the Enter key to enter the SURVCONF menu and use the Up or Down control keys until MODE is displayed on the screen. Press Enter again and use the Up or Down control keys until the desired mode is displayed. Press Enter to select that mode.

Once the desired survey mode is selected, only the parameters relevant to that choice will be available. Access these parameters by using the Up/Down control keys.

Complete the survey setup procedure by going to the SURVEY:<current mode> menu. Note that certain choices made in the SURVCONF screen will affect what parameters and options are available in the SURVEY: <current mode> menus.

SURVCONF: STATIC

- **Recording Interval** (REC INT: *.*.s)

Displays and sets the data recording interval. To change this parameter press the Enter key and use the control keys to enter the desired value in seconds. The default is 20 seconds. The valid range is 0.2 - 999 seconds.

- **Elevation Mask (ELEV MASK: **)**
Displays and sets the data collection elevation mask. To change this parameter press the Enter key and use the control keys to enter the desired value in degrees. The default is 10 degrees.
- **SBAS (SBAS:xx)**
Enables (ON) or disables (OFF) the reception of SBAS satellites.
- **Mode (MODE: STATIC)**
Displays and sets the selected survey mode. Change the survey type by pressing the Enter key and use the Up or Down control key to choose the desired survey mode. Press Enter to select it. The mode selected will determine the parameters displayed.

SURVCONF: KINEMATIC

- **Epoch Counter (EPOCH COUNTER: ***)**
Displays and sets the value of the epoch counter. The epoch counter is the number of epochs that will be recorded at each point every recording interval. When the epoch counter counts down to 0, the Site ID (SITE) is automatically reset to question marks ("???"). Reset the epoch counter by entering a new Site ID. To change this parameter, press the Enter key, use the control keys to enter a value and press Enter to select it.
- **Minimum Number of Satellites (MIN SV: *)**
Displays and sets the minimum number of satellites required to perform a kinematic survey. If the number of locked satellites falls below this number, the receiver will issue a warning message and an alarm (beep) indicating that you must return to the last known point. To change this parameter, press the Enter key, use the control keys to enter a value, and press Enter to select it. The default is 0 (alarm disabled).
- **Recording Interval (REC INT: ***.s)**
Displays and sets the data recording interval. To change this parameter press the Enter key and use the control keys to enter the desired value in seconds. The default is 20 seconds. The valid range is 0.2 - 999 seconds.

- **Elevation Mask (ELEV MASK: **)**
Displays and sets the data collection elevation mask. To change this parameter press the Enter key and use the control keys to enter the desired value in degrees. The default is 10 degrees.
- **Mode (MODE: KINEMATIC)**
Displays and sets the selected survey mode. Change the survey type by pressing the Enter key and use the Up/Down control keys to choose the desired survey mode. Press Enter to select it. The mode selected will determine the parameters displayed.

SURVCONF:RTK BASE

- **Port and Type (PORT/TYPE)**
Displays and sets the RTK data link port and data type. The receiver will transmit the selected data type via the selected port. The data link (radio or GSM) must be connected to this port.
To set the port and data type, press Enter. The cursor will blink on the port field, indicating that this field is active. Use the Up/Down control keys to scroll to the desired port. Press Enter, and the cursor shifts to the data type field. Use the Up/Down control keys to scroll to the desired data type, and press Enter to select it. Possible data types are:
 - DBEN: Proprietary compact binary format
 - RTCM: RTCM type 18/19 and 3/22 are enabled
 - CMR: Compact Measurement Record (CMR) format
 - OFF: No RTK base station data is output.
- **Recording Interval (REC INT: ***.s)**
Displays and sets the data recording interval. To change this parameter press the Enter key and use the control keys to enter the desired value in seconds. The default is 20 seconds. The valid range is 0.2 - 999 seconds.

- **Elevation Mask (ELEV MASK: **)**

Displays and sets the RTK data elevation mask. To change this parameter press the Enter key and use the control keys to enter the desired value in degrees. The default is 10 degrees.

- **Mode (MODE: RTK BASE)**

Displays and sets the selected survey mode. Change the survey type by pressing the Enter key and use the Up/Down control keys to choose the desired survey mode. Press Enter to select it. The mode selected will determine the parameters displayed.

SURVCONF:RTK ROVER

The parameters available from this menu are illustrated in the diagram below:

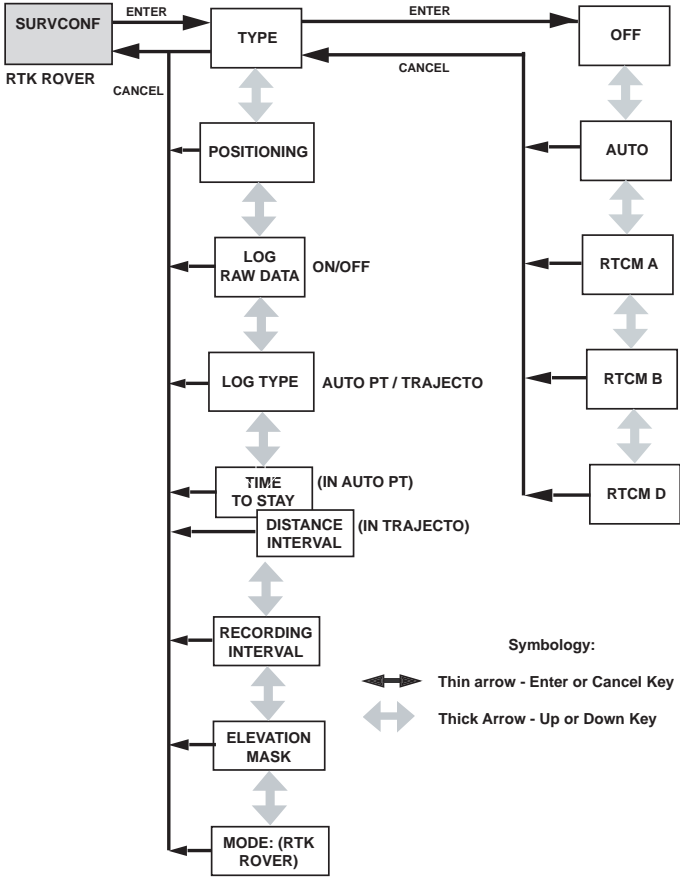

- **Data Type and Port (TYPE: ****)**

This parameter displays and sets the RTK data type and port. To change this parameter, press the Enter key and use the Up/Down control keys to choose the desired port and type. Press enter to select it. The possible settings are:

- OFF: RTK rover mode is off.
- AUTO: Will automatically detect CMR, CMR+, DBEN, or DSNP format on any port.
- RTCM A - RTCM D: RTCM format on port A, B, or D.

- **RTK Positioning Algorithm (POSITIONING)**

Displays and sets the RTK positioning algorithm. COARSE outputs fast RTK positions. FINE outputs time-tagged RTK positions. The default is COARSE. To change the setting, press the Enter key and use the control keys to select the desired algorithm.

- **Log Raw Data (LOG RAW DATA)**

Display and sets raw data collection status. ON will log raw data (B, E, and S files) along with the epoch solution file (CBEN data) and the vector solution file (OBEN file). OFF will log the CBEN and the OBEN files only. The default is ON. To change this setting, press the Enter key and use the control keys to select ON or OFF and press Enter.

- **RTK Logging Method (LOG TYPE:)**

Displays and sets the method of RTK logging. The options are Auto Point (AUTO PT) and Trajectory (TRAJECT). Select AUTO PT if you wish to occupy points for a set period of time. Select TRAJECT if you are collecting data at set distance intervals. The default is AUTO PT. To change the setting, press the Enter key.

- **Time on point** (TIME TO STAY: *** s)
Visible only if LOG TYPE is set to AUTO PT. This parameter defines how long each point will be occupied in seconds. Valid interval is 0 - 999 seconds. The default is 10 seconds. To change this parameter, press the Enter key.
- **Distance interval** (DISTANCE INTERVAL: *.* m)
Visible only if LOG TYPE is set to TRAJECT. This parameter sets the distance interval between point computation during a trajectory survey. Valid range is 0.0 - 999.9 meters. The default is 0.0 meters. To change this parameter, press the Enter key.
- **Recording Interval** (REC INT: *.*.s)
Displays and sets the data recording interval. To change this parameter press the Enter key and use the control keys to enter the desired value in seconds. The default is 20 seconds.
- **Elevation Mask** (ELEV MASK: **)
Displays and sets the RTK data elevation mask. To change this parameter press the Enter key and use the control keys to enter the desired value in degrees. The default is 10 degrees.
- **Mode** (MODE: RTK ROVER)
Displays and sets the selected survey mode. Change the survey type by pressing the Enter key and use the Up or Down control key to choose the desired survey mode. Press Enter to select it. The mode selected will determine the parameters displayed.

SESSIONS (Session Control)

- **Stop a session (STOP SESSION)**
Stops the data recording during the current session. Should be done prior to removing the SD memory card. To stop a session, press the Enter key. The query "Stop Session?" will appear on the display. Press Enter to confirm or Cancel to cancel.
- **Restart a session (START SESSION)**
Restarts data collection during the current session. Must be done to continue data collection if a STOP SESSION has been performed. To restart a session, press the Enter key. The query "Start Session?" will appear on the display. Press Enter to confirm or Cancel to cancel.
- **List/delete sessions in memory (LIST SESSIONS)**
Lists all of the session files on the memory card in the order that they were recorded. Individual session files can be deleted by using the Up or Down control key to select a file, and pressing the Enter key. The query "Delete file?" appears. Press Enter to confirm or Cancel to cancel.
- **Create a new session (NEW SESSION)**
Closes the current session file and opens a new file. To create a new session, press the Enter key. The query "Create new session?" will appear on the display. Press Enter to confirm or Cancel to cancel.
- **Delete session files from memory (DELETE ALL)**
Deletes all of the session files on the memory card. To delete all data files, press the Enter key. The query "Delete ALL sessions?" will appear on the display. Press Enter to confirm or Cancel to cancel.

SETTINGS

- **Reset memory (MEMORY RESET)**

Memory reset will clear the internal memory. User settings will revert to their default values and the ephemeris and almanacs will be cleared. Press Enter to initiate the reset. The query "Reset memory?" will be displayed. Press Enter to confirm or Cancel to cancel.
- **Restore defaults (RESET TO FACTORY DEFAULTS)**

This function restores receiver parameters to their default values. Press Enter to initiate the reset. The phrase "Reset to factory defaults?" will be displayed on the screen. Press Enter to confirm, or Cancel to cancel.
- **Serial port baud rate (BAUD RATE)**

Displays and sets the baud rate for each port. Valid baud rates are 300, 600, 1200, 2400, 4800, 9600, 19200, 38400, 57600, and 115200. The default for each port is 9600. To change a baud rate, press Enter and use the Up or Down control key to scroll through the current baud rate setting for each port. When the port of interest is displayed, press Enter and use the Up or Down control key to choose the desired baud rate for that port. Press Enter to select it.
- **Set screen language (LANGUAGE)**

Displays and sets the display language. This parameter affects the language for all display menus and submenus as well as the front panel warning messages. Five languages are available: English, French, German, Italian, and Spanish. To change the language, press the Enter key and use the Up or Down control key to select the desired language. Press Enter to set the new language.

- **Enable/disable Beeper (BEEP)**
Allows you to turn the receiver beeper on or off. Be aware that this will turn off the display beeper as well as any audible alarms issued during warning messages. To change the setting, press the Enter key.
- **Save receiver parameters (SAVE)**
Saves the current user parameter settings to memory. Saved parameters will not be lost when the receiver is powered cycled. To save parameters, press the Enter key, the query "Save settings?" appears. Press Enter to confirm or Cancel to cancel.

COM OPTN

Thales Radio

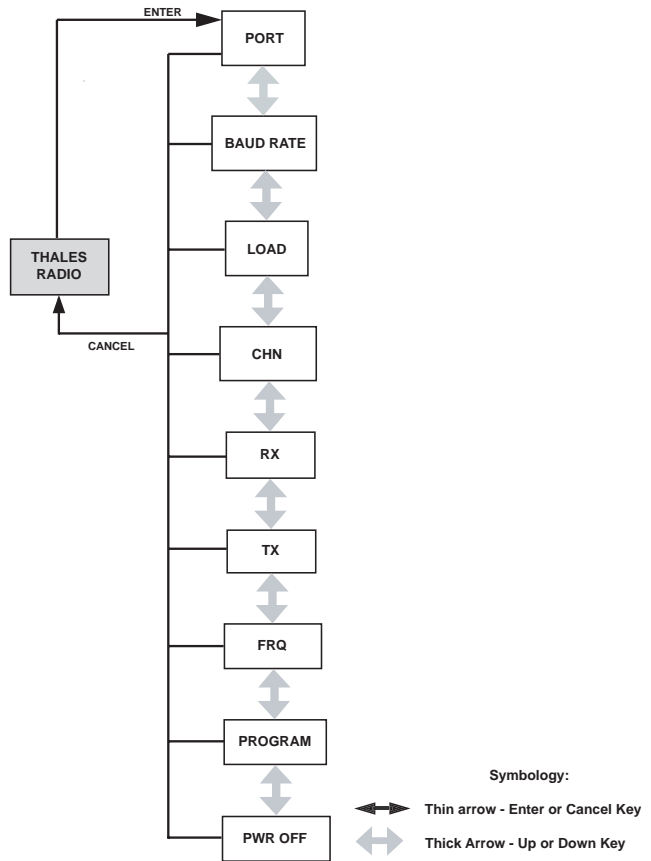

Note: it is recommended that you configure the parameters in the order in which they are displayed. In particular, you must load the radio parameters (LOAD) prior to sending user settings (PROGRAM).

- **Radio serial port setting (PORT)**

This is the serial port to which the radio is connected. Valid settings are B or D. Port D (default) is the internal port and must be selected if the communication module is being used. If an external Thales U-Link radio is used, the radio should be attached to serial port B. When this parameter is set to port B, the port protocol will be switched to RS-422 (required for Thales radios). Any other port selection will change the port B protocol to RS-232. To select a port, press Enter to access the sub-menu, scroll to the desired port setting and press Enter to select it.

- **Radio Baud Rate (BAUD)**

This submenu sets the baud rate of the radio serial port. Valid baud rates are 300, 600, 1200, 2400, 4800, 9600, 19200, 38400, 56800, and 115200. The default is 19200 and should not be changed. To select the baud rate, press Enter, scroll to the desired baud rate, and press Enter to select it.

- **Load radio parameters to the receiver (LOAD)**

Press the Enter key to load Thales radio parameters to the receiver. This is done to ensure that any other active data links are fully turned off and the receiver is ready to use the Thales radio. Perform a LOAD before attempting to send user parameters (PROGRAM) to the receiver.

- **Channel selection (CHN: **)**

Displays and sets the radio frequency channel number. Channel numbers range from 00 to 15 and each channel number is linked to a particular radio frequency set at the factory. To set the channel number, press Enter and use the control keys to pick a channel number and press Enter to select it.

- **Receive frequency (RX: ***.****)**
Displays the receive frequency in MHz. This field will display the receive frequency matched to the channel number (CHN) parameter.
- **Transmit frequency (TX: ***.****)**
Displays the transmitter frequency in MHz. This field will display the transmit frequency matched to the channel number (CHN) parameter.
- **Frequency (FRQ: ***.****)**
Displays the current receive/transmit frequency. This field is useful when the frequency cannot be found in the channel table, since in this case, both RX and TX will show 0. When the current frequency matched the channel table, RX or TX will be equal to FRQ.
- **Send user selected parameters to the receiver (PROGRAM)**
Press the Enter key to send your selected radio parameters (frequency, channel) to the receiver. Any errors in sending the parameters will trigger a warning message that will be displayed on the front panel.
- **Power off the radio (PWR OFF)**
This is NOT a power status indication for the radio, but a function to turn off the radio in the Communication Module. It is required that the port needs to be set to D before entering this field. Press the Enter key to power off the Thales radio.

PDL Radio

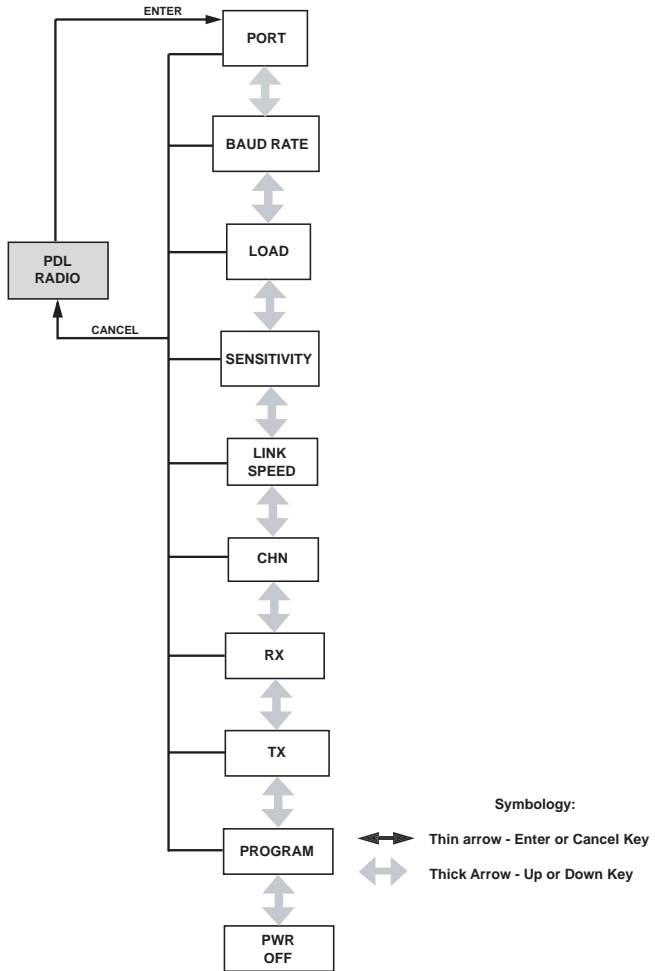

- **Radio serial port setting (PORT)**

The PORT submenu sets the serial port to which the radio is connected. Port options are A, B, or D. The default is port D (the internal radio port) and should not be changed if using the Communication Module. To select a port, press Enter to access the submenu, scroll to the desired port setting and press Enter to select it.

- **Radio baud rate (BAUD RATE)**

This submenu sets the baud rate of the radio serial port. Valid baud rates are 300, 600, 1200, 2400, 4800, 9600, 19200, 38400, 57600, and 115200. The default is 19200 and should not be changed if using the Communication Module. To select the baud rate, press Enter, scroll to the desired baud rate, and press Enter to select it.

- **Load radio parameters to the receiver (LOAD)**

Press the Enter key to load PDL radio parameters to the receiver. This is done to ensure that any other active data links are fully turned off and the receiver is ready to use the PDL radio. Perform a LOAD before attempting to send user parameters (PROGRAM) to the receiver.

- **Radio sensitivity (SENSITIVITY)**

This submenu sets the radio sensitivity. Options are LOW, MEDIUM, HIGH and OFF. Normal settings are LOW for the external transmitter and HIGH for the radio receiver. It is recommended that this parameter is never set to OFF. To select the sensitivity, press Enter, scroll to the desired value and press Enter to select it.

- **Link speed (LINK SPEED)**
This submenu sets the radio link speed. Options are 4800, 9600, and 19200. The default is 9600. To select the link speed, press Enter, scroll to the desired value and press Enter to select it.
- **Channel selection (CHN: **)**
Displays and sets the radio frequency channel number. Channel numbers range from 00 to 15 and each channel number is linked to a particular radio frequency set at the factory. To set the channel number, press Enter, scroll to the desired channel number, and press Enter to select it.
- **Receiver frequency (RX: *.**)**
Displays the receiver frequency in MHz. This field will display the frequency matched to the channel number (CHN) parameter.
- **Transmit frequency (TX: *.**)**
Displays the transmit frequency in MHz. This field will display the transmit frequency matched to the channel number (CHN) parameter.
- **Send user selected radio parameters to the receiver. (PROGRAM)**
Press the Enter key to load your selected radio parameters (channel, sensitivity, link speed) to the receiver. Any errors in sending the parameters will trigger a message that will be displayed on the front panel.
- **Power off the radio (PWR OFF)**
This is NOT a power status indication for the radio, but a function to turn off the radio Communication Module. The Port must be set to D before entering this field. Press the Enter key to power off the PDL radio.

GSM Rover

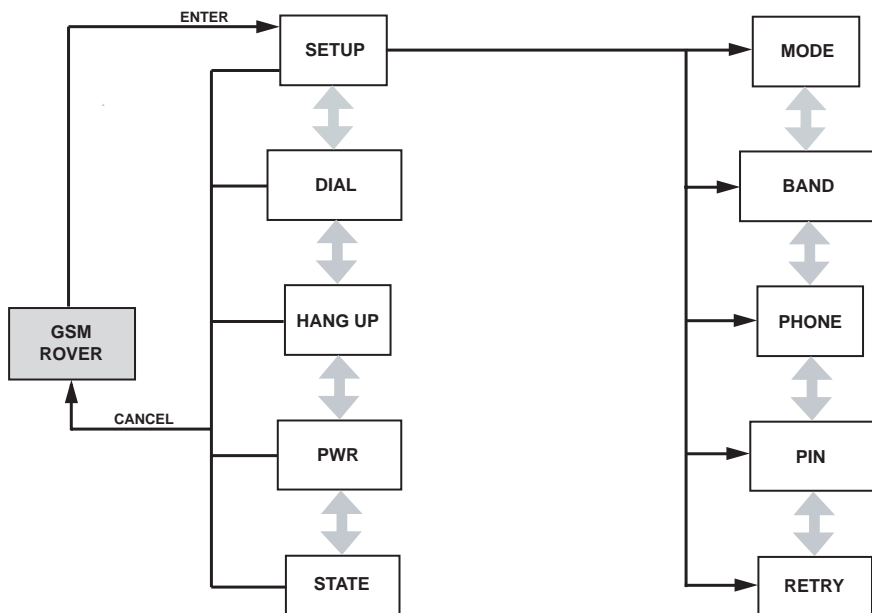

Symbology:



Thin arrow - Enter or Cancel Key



Thick Arrow - Up or Down Key

- **Configure the GSM (SETUP)**

This submenu is the entry point for the initial setup of the GSM modem. Press the Enter key to access the following parameters:

- **Set MODE (MODE:)**

Select either AUTO mode for the rover to call the base automatically, or MANUAL to manually dial the base receiver. To select the mode, press Enter, scroll to the desired value and press Enter to select it. The default is AUTO.

For the receiver to dial the base automatically, the modem must be turned on using the PWR parameter (see below) and CPD or RTCM rover mode must be enabled and set to the correct port.

- **Band setting (BAND: ****)**

The band parameter sets the operable frequency band. In general, set this parameter to 1900 in North America or 900/1800 elsewhere, but verify this with your GSM service provider. To select the band, press Enter to access the submenu, scroll to the desired value and press Enter to select it.

• **Phone number (PHONE: *****)**

This parameter sets the phone number of the base station GSM modem. The field will allow from 7-11 digits. To set the phone number, press Enter and use the control keys to enter the number.

NOTE: Be sure to enter the phone number of the GSM modem you want to call (the base receiver modem), and not the number of the modem you are currently configuring.

• **PIN number (PIN: ****)**

Sets the Personal Identification Number required to access the GSM modem SIM card. This number is provided by your service provider, and ranges from 4-8 digits. To set the PIN, press Enter and use the Up or Down control key to enter the PIN number. If no PIN number is set in the SIM card then nothing is entered in this field.

- **Number of retries (RETRY: **)**

This parameter sets the number of times the rover modem will attempt to redial the base modem before giving up. Valid values are from 0 to 15. To set the number of retries, press the Enter key and use the control keys to enter a value. The default number of retries is 2.

- **Dial the base GSM modem (DIAL)**

This parameter dials the base modem. To dial the base modem, press Enter. A confirmation message "Dial base?" will appear. Press Enter to confirm or Cancel to cancel. The modem will dial the number entered in the SETUP submenu. While dialing, the STATE submenu (see below) will display "DIALING". When the connection has been established, the STATE submenu will display "ONLINE".

- **Disconnect the call (HANG UP)**

Press Enter to terminate the current connection to the base modem. The confirmation message "Disconnect call?" will appear. Press Enter to confirm or Cancel to cancel.

- **Power on/off the modem (PWR: **)**

The PWR submenu is NOT a power status indicator for the GSM modem, but a submenu that allows you to power the modem on or off. The power must be turned on for the GSM modem to be used; AUTO mode will not automatically turn on the modem. Once the power is turned on the modem will automatically initialize to the carrier. To change the power status, press Enter and scroll to either OFF or ON. Press Enter to select it. The modem status can be monitored in the STATE submenu (see below).

- **GSM modem operational status (STATE: **)**

Displays the current state of the GSM modem. Status values are:

- GSM ON = power on
- GSM OFF = powered off
- GSM INITIALIZED = modem has been initialized
- DIALING = dialing the base modem
- ONLINE = powered on and connected to the base modem.

GSM Base

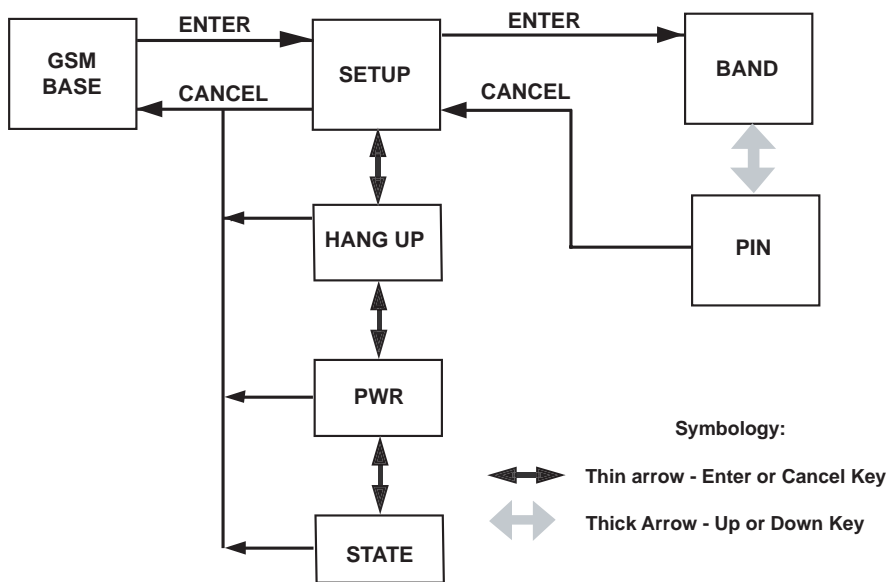

- **Configure the GSM (SETUP)**

This submenu is the entry point for the initial setup of the GSM modem. Press the Enter key to access the following parameters:

- **Band setting (BAND: ****)**

The band parameter sets the operable frequency band. In general, set this parameter to 1900 in North America or 900/1800 elsewhere, but verify this with your GSM service provider. To select the band, press Enter, scroll to the desired value and press Enter to select it.
- **PIN number (PIN: ****)**

Sets the Personal Identification Number required for the GSM modem SIM card. This number is provided by your GSM service provider, and ranges from 4-8 digits. To set the PIN, press the Enter key, use the control keys to enter the number, and press Enter again to select it.
- **Disconnect the call. (HANG UP)**

Press Enter to terminate the current connection to the remote modem. The confirmation message "Disconnect call?" will appear. Press Enter to confirm or Cancel to cancel.
- **Power on/off the modem. (PWR: **)**

The PWR submenu is NOT a power status indicator for the GSM modem, but a submenu that allows you to power the modem on or off. The power must be turned on for the modem to be used. Once the power is turned on the modem will automatically initialize to the carrier. To change the power status, press Enter to access the submenu, scroll to either OFF or ON and press Enter to select it. The modem status can be monitored in the STATE submenu (see below).
- **GSM modem operational status. (STATE: **)**

Displays the current state of the GSM modem. Status values are:

 - GSM ON = power on
 - GSM OFF = powered off
 - GSM INITIALIZED = modem has been initialized
 - ONLINE = powered on and connected to the remote modem.

Warning Messages

The Z-Max.Net unit monitors a number of conditions that are of interest to the user. Whenever a problem is detected in one of these conditions, the LED display is interrupted to show a warning message stating the problem. The warning message scrolls across the display to distinguish it from a regular menu parameter, and a beep will sound every 10 seconds (unless the beep has been disabled by the user).

Press any key to acknowledge the message, which removes the warning text from the display and stops the beep. If the receiver is experiencing more than one problem at the same time, the receiver will generate a separate warning for each problem. In this case, the receiver will display the highest priority warning first. When this warning is acknowledged, it will display the next highest priority warning. This process will continue until all warnings have been acknowledged. The table below describes the possible warnings the unit may issue.

Warning	Definition	Action
THALES RADIO WARNINGS		
Wrong setting	A conflict in one of the parameters is preventing radio programming.	Check and reset radio parameters.
Communication Error	A timeout or checksum error has occurred during setup or user is trying to power off an external device by front panel menu.	Recheck the port and baud rate parameters.
Not Loaded Yet	The LOAD function was not performed prior to programming user parameters.	Load radio parameters (LOAD) submenu and then resend the user parameters (PROGRAM) submenu.
PDL RADIO WARNINGS		
Channel Not Programmed	The frequency channel selected is not programmed in the channel table.	Reload (LOAD) radio parameters.
Wrong setting	A conflict in one of the parameters is preventing radio programming.	Check and reset radio parameters.
Communication Error	A timeout or checksum error has occurred during setup, or the external radio has been powered off.	Recheck the port and baud rate parameters. If using an external radio, verify it is powered up.
Not Loaded Yet	The LOAD function was not performed prior to programming user parameters.	Load radio parameters (LOAD) submenu and then resend the user parameters (PROGRAM) submenu.
GSM WARNINGS		
MODEM Not Detected	GSM modem not detected	Verify a GSM modem is in the Radio Module, and verify that the module is securely connected.

Warning	Definition	Action
MODEM Not Responding	Can not communicate with GSM modem	Verify a GSM modem is in the Radio .Module, and verify that the module is securely connected.
Enter Phone Number	Need to enter Base receiver phone number	Enter the correct base station GSM modem phone number.
MODEM No Carrier	Attempt to call Base receiver unsuccessful	Verify that the GSM base is up and operational.
MODEM Line Busy	Base receiver gives busy signal when called	Re-try later.
MODEM Invalid PIN	PIN is required and the one provided by user is incorrect and does not work.	Verify PIN number.
MODEM SIM Card Locked	Wrong PIN has been entered, causing the SIM card to lock up.	Contact your GSM service provider.
MODEM Insert SIM Card	There is no SIM card in the Communication Module.	Insert valid SIM card.
MODEM Initialization Error	Cannot initialize modem	1. Verify the BAND is correct. 2. The GSM network may be temporarily down. Wait 20-30 minutes and try again. 3. Contact your service provider.
MODEM SIM Card Failure	SIM card failed.	Contact your GSM service provider.
RTK/RTCM WARNINGS		
Solution Is Float	The CPD solution is a float not a fixed solution.	n/a
Invalid Site ID	One or more characters entered in the Site ID field are invalid	Re-enter valid Site ID
Distance Interval is 0 Meter	For a trajectory survey, the distance interval must be > 0 meters.	Enter a value > 0 in the Distance Interval field of the SURVCONF sub-menu.
Time To Stay Is 0 Second	For an Auto Point survey, the Time to Stay must be > 0 seconds.	Enter a value > 0 in the Time To Stay field of the SURVCONF sub-menu.
Not Receiving Base Data	Not receiving RTK carrier phase data from the base receiver.	Check serial/data link with the base. Ensure base is computing a position. Ensure a valid position was entered into the base receiver.
Not Receiving RTCM Base Data	Not receiving RTCM code phase corrections from the base receiver.	Check serial/data link with the base. Ensure base is computing a position. Ensure a valid position was entered into the base receiver.
Bad Base Coordinates	The position entered in the base receiver for CPD operation is not correct (too far from the computed position).	Enter the correct base position.
Bad RTCM Base Position	The position entered in the base receiver for RTCM code operation is not correct (too far from the computed position).	Enter the correct base position.
BATTERY WARNINGS		

Warning	Definition	Action
Int. Battery Error: SMBus	The SMBus control for the internal battery communication is not working.	Remove Power Module and reinsert it.
Int. Battery Error: Access	Can't access the internal battery.	Remove Power Module and reinsert it.
Low Int. Battery: < 10 min	Remaining life of internal battery is < 10 minutes.	Change Power Module, or attach external battery.
Low Int. Battery: < 30 min	Remaining life of internal battery is < 30 minutes.	Change Power Module, or attach external battery.
Low Backup Battery	The internal battery that powers the non-volatile memory and the real-time clock is low and needs to be changed.	Contact Customer Support. Backup battery must be replaced.
MEMORY WARNINGS		
† Memory Test Error: RAM	Error with RAM	Perform a receiver initialization.
† Memory Test Error: BBRAM	Error with battery backed up memory.	Perform a receiver initialization.
† Memory Test Error: ROM	Error in the ROM (flash).	Perform a receiver initialization.
† Memory Test Error: BOOT	Error with boot section of flash	Perform a receiver initialization.
SD MEMORY CARD WARNINGS		
No Data Card Detected	The SD memory card is either missing or not properly inserted and has not been detected; no data recording will be done.	Insert or re-insert SD memory card.
Data Card Full	There is no space left on the SD memory card.	Delete data from the current card or replace current SD memory card with another SD memory card with available memory.
† Data Card Full < 5 min	There is less than 5 minutes of data recording left on the current SD memory card.	Delete data from the current card or replace current SD memory card with another SD memory card with available memory.
Data Card Error: Access	Cannot read or write to SD memory card.	Power cycle receiver. If problem persists, re-initialize the receiver using the power key (download data first). If problem persists, replace the SD memory card.
Data Card Error: Update	Cannot update the FAT (file allocation table) of the SD memory card.	Power cycle receiver. If problem persists, re-initialize the receiver using the power key (download data first). If problem persists, replace the SD memory card.
Data Card Error: Create	Cannot create the files for a new session: cannot record data.	Power cycle receiver. If problem persists, re-initialize the receiver using the power key (download data first). If problem persists, replace the SD memory card.

Warning	Definition	Action
Data Card Error: Rename	Cannot rename the files of the session.	Power cycle receiver. If problem persists, re-initialize the receiver using the power key (download data first). If problem persists, replace the SD memory card.
Data Card Error: Corrupted FAT	File Allocation Table on the SD memory card has been corrupted.	Power cycle receiver. If problem persists, re-initialize the receiver using the power key (download data first). If problem persists, replace the SD memory card.
MISCELLANEOUS WARNINGS		
Not Enough Satellites	Tracking fewer than the minimum number of satellites required for kinematic survey.	The kinematic survey must be reinitialized on the last point.
Antenna Overload	Antenna installation problems. The setup is drawing more than 150 mA (there is a short on the antenna cable or the LNA is drawing too much current).	Check that the antenna connection is secure. If using optional cables, check for loose or incorrect connection or damaged cable.
No Antenna Detected	No GPS antenna has been detected by the receiver.	Verify antenna connection is secure. If a DC block is being used as part of a multiple antenna setup, check that at least 1 receiver is not DC blocked.
High Receiver Temperature	Internal receiver temperature is > 80 degrees Celsius. The receiver will automatically turn off at 82 degrees.	Shield receiver from the sun or increase air flow around the receiver.
Download in Progress	Receiver is currently downloading data from the SD memory card to a PC. No session management operations can be conducted at this time.	Wait for download to complete operation before performing the command. If Download is not running, run Download again to perform proper shut-down routine.
† - Indicates warning is permanent. The warning will NOT go away if the condition disappears, but only if it is acknowledged.		

7. Power Management

Power Module Types

The primary power source for the Z-Max is the power module. Inside the power module are rechargeable lithium ion battery cells. Two types of power module are available:

- The *Max-Run* power module, which has a capacity of 8.8 amp-hours and should power the Z-Max for over 14 hours in typical user scenarios.
- The *Max-Lite* power module, which is a lighter configuration that provides 4.4 amp-hours of power. The Max-Lite power module is capable of powering the receiver for over 6 hours in typical user scenarios.

The power module also contains a battery charger and other "smart" functionality to provide usage information, monitor the battery while it's recharging, and advise the user about battery maintenance.

The power module does not require any cables; it simply plugs into the left-hand side of the receiver module.

Battery Time Remaining

To help you keep track of battery life, the power module has a pushbutton and LED indicators to provide a quick indication of the percentage of battery time remaining.

Each of the four lights represents about 25% of battery life. Four green lights indicate the battery is fully charged (100%). One red light indicates that there is less than 25% of battery life left. The LEDs only provide a rough indication of battery life to the nearest 25%. Also, because the pushbutton is on the side of the power module that connects to the receiver module, the pushbutton can only be used to check battery life with the power module removed from the receiver.

For a more precise report of the amount of battery time remaining or to check battery life with the power module attached, see the BAT function in the SYSINFO menu of the front panel user interface (page 128).

Missing picture

Missing picture

External Power

If you require additional or backup battery power, an external power source can be used. An external DC power source connects to the Z-Max external power port via a dedicated power cable. Voltage must be between 10-28 V DC. The external power source can be connected at any time without concern for damage to the power module.

When both the power module and an external power source are connected, the Z-Max will use power from the external source first. When the unit transitions from an external source to an internal source, or from an internal source to an external source, there is no interruption to any data recording or receiver functionality.

Charging

The power module contains rechargeable lithium-ion battery cells and ‘smart’ charging circuitry. Recharging the power module is done using the AC/DC power supply included with the system. This power supply can be used to provide power to the Z-Max through an external connector. The charger is designed to work with a 110-240 VAC power source and delivers 12 V DC of input voltage with at least 4 A current capability to the power module.

The power module’s lithium-ion batteries do not have a memory effect, meaning that they can be recharged without being fully discharged with no effect on the battery capacity. In other words, recharge the power module whenever it’s convenient. To extend the life span of the batteries in the power module, it is best not to always fully discharge them. To keep your power module ready for field use, we recommend that you keep it connected to the charger when not in use.

The charging of the power module from a fully discharged state takes about five hours. To charge, remove the power module from the receiver module and plug the charger into the connector on the module. Plug the charger into a 100-240 V AC power source. The status lights on the charger indicate the following:

- Yellow - Standby
- Red - Charging
- Green - Charged
- Blinking Red - Error.

Conditioning

The battery circuitry in the power module stores and communicates charge capacity and charge level information. The accuracy of the charge level indicator will degrade over time. When this happens, the battery information obtained from the front panel display or the power module button will no longer be accurate. To restore the accuracy of the charge level, the power module must be calibrated or conditioned.

While the power module is initially conditioned at the factory, conditioning should be done periodically to calibrate the power module and restore the charge level accuracy. **We recommend that the power module be calibrated every 20 charge cycles, or about once a month, whichever comes first.** The power module should also be conditioned after prolonged periods when the battery has been stored while not connected to the charger.

Conditioning is a three-step process. The first step charges the battery to capacity, the second step discharges the battery at a constant rate. The third step again charges the battery to capacity. There are two methods for conditioning the power module. The first method relies completely on the charger to do the calibration. The second method uses both the receiver and the charger.

To condition the power module with the charger:

1. Remove the power module from the receiver module.
2. Plug the charger into an electrical socket.
3. Push the power module pushbutton that controls the power module LEDs
4. While continuing to push the button, plug the charger into the power module. This combination of pushing the button and plugging in the charger will initiate the conditioning sequence.

The entire conditioning process (all three steps) will take up to 18 hours for the Max-Run power module and up to 12 hours for the Max-Lite power module. While calibration is in progress, the status lights on the charger will indicate the following:

- Yellow - Calibrate mode is in progress
- Off - Calibration completed

Disposition

If the power module fails to hold an adequate charge, either due to damage or because it has outlived its useful life, the power module can be returned to Thales for refurbishing.

Refer to the hardware limited warranty information for specifics regarding warranty repairs. If for any reason you are unable to return the module, the cells in the module may be recycled, or the modules may be discarded. Spent lithium batteries are not considered hazardous waste because they are neither toxic nor reactive.

Battery Life

From a fully charged 8.8-Ah power module, a Z-Max.Net unit used as an RTK rover will operate **during 13.8 hours** at +25°C (77°F). The table below gives variations of the battery capacity versus temperature.

Temperature		Relative Battery Life vs. Temperature
°C	°F	
+60°	140°	85%
+45°	113°	95%
+25°	77°	100%
-10°	14°	70%

Power Drain

The table below provides consumption figures for the Z-Max.Net unit when powered from a 12-V DC power source applied to its power port. Measurements were made at the output of the external source.

Mode	Display	Current drain (mA)	Power (W)
RTK rover with Thales UHF data link	OFF	430	5.15
	ON	540	6.5
Static	OFF	385	4.6
	ON	470	4.65

Storage

The power module includes an automatic battery charger that consumes energy, including when the power module is left idle or stored separately.

The residual current is approximately 1 mA, which means the power module will self-discharge by about 0.7 Ah per month.

The best storage conditions for a power module are the following:

- Ambient temperature: -10°C to $+20^{\circ}\text{C}$ (14°F to 70°F)
- Charge status at the beginning of the storage period: 50% or more

After Storage

If the power module has been stored for more than 4 months, check the battery status before use and charge it if necessary

Warning! If a power module has been left uncharged for an excessively long time, the battery voltage will be so low that recharging will be impossible. In this case, you will have to return the power module to Thales for maintenance.

Li-Ion Internal Battery Specifications

Manufacturer	Emerging Power Inc. (USA) / Saehan Enertech Inc. (Korea)
Model	Rechargeable Li-Ion Smart Battery Pack Li42SX-88A / D160A (8.8 Ah - 7.4 V DC)
Capacity	8.6 Ah minimum, 8.8 Ah standard at 25°C
DC Output Voltage	When used: 7.4 V When charged: $8.4\text{ V} \pm 0.5\text{ V}$
Cell Configuration	2 packs of 4 cells (3.7 V - 2.2 Ah each)
Discharge Cutoff Voltage	6.0 V DC

8. \$PASH Proprietary Commands

Most commands that can be applied to the Z-Max.Net receiver are described in the *Z-Family Technical Reference Manual*.

The serial commands that are specific to Z-Max.Net are presented in this chapter and described in alphabetical order. These commands fall into two categories (as are all the \$PASH commands):

- Set commands (\$PASHS,...)
- Query commands (\$PASHQ,...).

Applying Serials Commands to Z-Max.Net

From the office Computer

Connect serial port COM1 on your computer to port A on Z-Max.Net using data cable P/N 700461.

Use GNSS Solutions' WinComm utility to send your serial commands. See *GNSS Solutions Reference Manual* for more information on WinComm.

From the Field Terminal

Use FAST Survey's Send Command to Receiver function. This function can be found on the Equip tab.

Assuming the communication with Z-Max.Net has been established via Bluetooth or a serial cable:

- Tap your command in the Command to Send field using FAST Survey's virtual keyboard. This keyboard automatically appears when you tap inside the field.
- Click OK. The command is sent to the receiver. FAST Survey then displays a new window in which you can read the response string returned by the Z-Max.Net receiver (data line at the bottom of the window).
- Tap the Close button to return to the Send Command to Receiver dialog. You can now type a new command and send it back to the receiver.

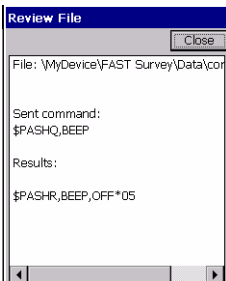
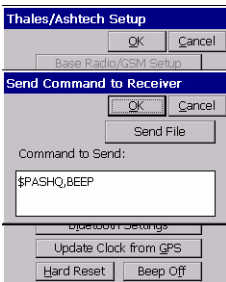

Command Summary Table

The table below summarizes all the commands, classified according to topic, and the corresponding page numbers in this chapter.

Topic	Set Commands (\$PASHS,..)	Page	Query Commands (\$PASHQ,..)	Page
Data logging	REC	188		
Direct IP	DIP	173		
Errors			WARN WARN,MDM	211 213
Misc.			BAT BEEP	196 197
Modem	MDM,DAL MDM,INI MDM,OFF MDM,ON MDM,PAR	174 175 175 176 177	MDM MDM,LVL	197 199
NTRIP	NTR,LOD NTR,MTP NTR,PAR	181 181 182	NTR NTR,TBL	200 201
Radio	RDP,CHN RDP,FRM RDP,LOD RDP,LSP RDP,OFF RDP,ON RDP,PRG RDP,SST RDP,TYP	183 184 184 185 185 186 186 187 187	RDP RDP,CHT RDP,FRM RDP,TYP RDP,USR	202 204 205 206 207
RTCM	NME,MSG RT3,BAN RT3,BAS RT3,OFF RT3,POS RT3,STI RT3,TYP RTC,WAT	179 188 189 189 190 191 191 192	RT3	210
SBAS	SBA SBA,AUT SBA,MAN	193 193 195		
Serial Ports	PRT	182	MDP	199

Set Commands

DIP

Function: Provides the Z-Max with the IP parameter enabling it to receive RTK corrections data in Direct IP mode.

Command:

\$PASHS,DIP,RIP,s1,PRT,d1<CR><LF>

Parameter	Description	Range
s1	Remote IP address in the standard form: "xxx.xxx.xxx.xxx" (Ipv4)	000.000.000.000 to 255.255.255.255
d1	Port number	0-65535

Return message: ACK or NAK

Example:

\$PASHS,DIP,RIP,134.20.2.100,PRT,6666<CR><LF>

Option Required: Remote Monitor option (M)

MDM,DAL

Function: Dials the number stored in memory (in CSD mode) or hangs up. The rover dials the phone number stored in the Z-Max memory using the \$PASHS,MDM,PAR command.

In case of connection loss, a re-dial strategy is used for both modes only if the ADL parameter of the \$PASHS,MDM,PAR command has been set to 'Yes'.

Command:

\$PASHS,MDM,DAL,c <CR><LF>

Parameter	Description	Range
c	1 - Dial number 0 - Hang up	0 - 1

Return message: ACK or NAK

Note: ACK is sent when the modem starts a dial or hang-up sequence. To make sure the dial/hang-up sequence was a success, check the modem status using the \$PASHQ,MDM command.

See also:

\$PASHQ,MDM

Option required: Remote monitor option (M).

MDM,INI

Function: Initializes the modem. In GPRS or base mode, this command also sends the IP address to the FTP site. In case of connection loss and if the ADL parameter of the \$PASHS,MDM,PAR command has been set to 'Y', an automatic registration on the FTP site is performed.

Command:

\$PASHS,MDM,INI<CR><LF>

Return message:

\$PASHR,MDM,INI,OK*7A<CR><LF>

\$PASHR,MDM,INI,FAIL*7C<CR><LF>

Option required: Remote monitor option (M).

Comment: For a GPRS connection, the differential mode (ROV,BAS,DIS) should be defined before applying the \$PASHS,MDM,INI command. In the following conditions, a NAK response will be output from the Z-Max:

- Differential mode not defined as ROV or BAS
- Mode changed during initialization with \$PASHS,MDM,INI
- Modem port not defined.

MDM,OFF

Function: Turns modem off.

Command:

\$PASHS,MDM,OFF<CR><LF>

Return message: ACK or NAK

See also:

\$PASHS,MDM,ON

Option required: Remote monitor option (M).

MDM,ON

Function: Turns the modem on.

Command:

\$PASHS,MDM,ON[,c,d1 [,d2]]<CR><LF>

Parameter	Description	Range
c (optional)	Serial port to which modem is connected	"A" or "D"
d1 (optional)	Modem type index: 0 – Robotics Sportster 1 – Telebit Worldblazer 2 – Telebit Trailblazer 3 – Telebit Cellblazer 4 – USER DEFINED 5 – Motorola G18 or G20 GSM Cellular	0 - 5
d2 (optional)	Interface Baud Rate settings (index). Default: factory setting used	3 – 8 (2400 – 57600)

Note: GSM Cellular must be connected to port D on Z-Max at 19200 baud rate.

Return message: ACK or NAK

See also:

\$PASHS,MDM,OFF

Example:

\$PASHS,MDM,ON,D,5,6 <CR><LF>

Option required: Remote monitor option (M).

MDM,PAR

Function: Sets the modem parameters.

Command:

```
$PASHS,MDM,PAR[,PIN,s][,PHN,s][,BND,d][,ADL,c][,RNO,d]
[,CBS,d1,d2,d3][,PTC,d][,IPT,s][,IPP,d][,APN,s1,LGN,s2,PWD,s3]
<CR><LF>
```

Parameter	Description	Valid for CSD	Valid for GPRS	Range
PIN,s	Needed to enable the modem SIM Card. Some GSM modems are pin-ready and do not require a PIN.	Yes	Yes	4 – 8 digits
PHN,s	Phone number to call (Base station phone number)	Yes	No	1 – 11 digits
BND,d	0 for 1900 GSM band, 1 for 900/1800 MHz GSM band	Yes	Yes	0 - 1
ADL,c	Y for "Auto-dial" mode, or N for "manual-dial" mode	Yes	No?	'Y' or 'N'
RNO,d	Number of re-dials if it can't connect the first time. The default is 2, which means that modem will dial three times before it gives up	Yes	No	0 -15
CBS,d1,d2,d3	Configures the type of CSD mode Where d1 is: 0= autobaoding 1= 300 bps (V.21) 2= 1200 bps (V.22) 4= 2400 bps (V.22bis) 5= 2400 bps (V.26ter) 6= 4800 bps (V.32) 7= 9600 bps (V.32) 65= 300 bps (V.110) 66= 1200 bps (V.110) 68= 2400 bps (V.110) 70= 4800 bps (V.110) 71= 9600 bps (V.110) Where d2 is always 0 Where d3 is: 0= transparent 1= non-transparent 2= both, transparent preferred 3= both, non-transparent preferred	Yes	No	d1= 1-2 digits d2= 1 digit d3= 1digit
PTC,d	Protocol type used with specified modem: 0= GSM data in CSD mode 1= GPRS via IP mode	Yes	Yes	0-1

IPT	Selection of the internet protocol	No	Yes	TCP or UDP
IPP	Selection of the IP port number for Point to point connection	No	Yes	1-65535
APN,s	Access Point Name used for GPRS connection Provided by the GSM provider Example: APN,orange.fr	No	Yes	32 characters max.
LGN,s	Login for GPRS connection Provided by the GSM provider Example: LGN,orange	No	Yes	32 characters max.
PWD,s	Password for GPRS connection Provided by the GSM provider Example: PWD,orange	No	Yes	32 characters max.

Return message: ACK or NAK

See also:

\$PASHQ,MDM

Examples:

\$PASHS,MDM,PAR,PIN,283645,PHN,14086151234,BND,0<CR><LF>

\$PASHS,MDM,PAR,CBS,7,0,1<CR><LF>

\$PASHS,MDM,PAR,PTC,1,APN,orange.fr,LGN,orange,PWD,orange<CR><LF>

Option required: Remote monitor option (M).

NME,MSG

Function: This command enables/disables the message type containing RTCM3.0 reference (base) station messages.

This command has already been used in the former RTCM format versions.

The following description is only valid when the RTCM3.0 format is activated by the \$PASHS,RT3,ON command.

Command:

\$PASHS,NME,MSG,c,s<CR><LF>

Parameter	Description	Range
c	Port ID	A,B,C,D
s	Enables or disables command	ON, OFF

Example:

\$PASHS,NME,MSG,A,ON <CR><LF>

(Enables RTCM3.0 messages on portA)

Return message: The return message is a \$GPMMSG,h,b*cc message where:

- **h** is the message header

The message header is the same in all RTCM-3.0 messages #1001-1008 and 1013. The header contains:

- Message number: 1001-1008, 1013
- Reserved field: set to 0
- Message length in bytes
- Station ID: 0-4095
- Time of transmission/reception: hhhmss.dd

- **b** is the message body

The message body is different for each message type. It contains all the fields described in the RTCM-3.0 standard, and in the order specified in this standard.

The only exceptions are for the message and Station IDs which are included in the message header.

See RTCM-3.0 description document for reference. All RTCM-3.0 fields are printed in their original format with the following exceptions:

- Pseudorange and Phase Range-Pseudorange fields are converted into meters
 - CNR are converted into dB.Hz
 - Reference coordinates and antenna height are converted into meters
- **cc** is the checksum

Examples of 1004,1006,1008,1013 messages:

```
$GPMMSG,
1004,0,133,0000,131459.00,
220499000,0,8,0,4,
5,0,59952.42,-0.1500,55,68,57.00,1,-1.54,-0.0390,55,50.00,
30,0,275688.92,-0.0890,55,73,50.00,1,-0.25,-0.0940,55,44.00,
17,0,177508.70,-0.1142,55,83,43.00,1,2.44,-0.1320,55,37.00,
9,0,125325.44,-0.0883,55,71,53.00,1,-0.97,-0.2060,55,47.00,
7,0,157383.54,-0.1572,55,78,49.00,1,-1.38,-0.0840,55,43.00,
24,0,138786.68,-0.1919,55,75,50.00,1,0.34,-0.0197,55,44.00,
14,0,237453.98,-0.1541,55,77,47.00,1,-1.53,-0.0300,55,41.00,
4,0,260238.08,-0.1473,55,71,53.00,1,-0.74,-0.1216,55,47.00*DF

$GPMMSG,1006,0,21,0000,131459.00,
2004,1,0,0,0,2861696.5548,0,2195711.5196,0,5242910.9954,0.0000*
DF

$GPMMSG,1008,0,22,0000,131459.00,
16,DORNE MARGOLIN T,0,0,*DF

$GPMMSG,1013,0,42,0000,131459.00,
53297,47686,9,13,1004,0,1.0,1006,0,1.0,1008,0,1.0,1013,0,1.0*DF
```

See also: \$PASHQ,RT3

Option required: Remote monitor option (M)

NTR,LOD

Function: Loads the source table to the Z-Max after the connection to a NTRIP caster has been established.

Command:

\$PASHS,NTR,LOD <CR><LF>

Return message:

\$PASHR,NTR,OK or

\$PASHR,NTR,FAIL

See also:

\$PASHQ,NTR

Option required: Remote monitor option (M).

NTR,MTP

Function: Provides the Z-Max with the mountpoint enabling it to receive RTK corrections data in NTRIP mode.

Command:

\$PASHS,NTR,MTP,s1,LGN<CR><LF>

Parameter	Description	Range
s1	String that indicates the name of the station (mountpoint). If s1=OFF disconnect from the station	100 characters max

Return message:

\$PASHR,NTR,OK or

\$PASHR,NTR,FAIL

Example:

\$PASHS,NTR,MTP,MUWF0<CR><LF>

\$PASHS,NTR,MTP,OFF<CR><LF>

Option required: Remote monitor option (M).

NTR,PAR

Function: Provides the parameters required to access a NTRIP caster through a GPRS connection.

Command:

\$PASHS,NTR,PAR,LGN,s1,PWD,s2,ADD,d1,PRT,d2<CR><LF>

Parameter	Description	Range
s1	Login string required to access the caster	32 characters max
s2	Password string required to access the caster	32 characters max
d1	Caster IP address in the form: "xxx.xxx.xxx.xxx"	4-15 digits
d2	Number of the IP port number used to access the caster	0-65535

Return message: ACK or NAK

PRT

Function: Sets the communication mode for Port B (RS422 or RS232).

Command:

\$PASHS,PRT,B,s<CR><LF>

Return message: None.

Parameter	Description	Range
s	Communication mode	"422" or "232"

See also:

\$PASHQ,MDP<CR><LF>

Example:

\$PASHS,PRT,B,422

Sets Port B to RS422 mode.

Comments: This command only works for Port B.

RDP,CHN

Function: Sets the radio channel index or, outside of the USA, the Thales radio frequency.

Command:

Format #1:

\$PASHS,RDP,CHN,d<CR><LF>

Format #2

\$PASHS,RDP,CHN,f<CR><LF>

Return message: None.

Parameter	Description	Range
d	Radio channel index	0-15
f	Radio frequency (only for Thales radio)	410-470 MHz

See also:

\$PASHS,RDP,LOD,c<CR><LF>

\$PASHS,RDP,PRG,c<CR><LF>

\$PASHS,RDP,LSP,d<CR><LF>

\$PASHS,RDP,SST,d<CR><LF>

Comment: Format #2 is only used outside of the USA to set the Thales radio frequency. In this case, the channel index is not used to select the Thales radio frequency.

Example:

\$PASHS,RDP,CHN,1<CR><LF>

(Sets radio channel index to 1)

\$PASHS,RDP,CHN,464.5<CR><LF>

(Sets Thales radio frequency to 464.5 MHz)

RDP,FRM

Function: Turns on or off the Thales radio frame.

Command: \$

PASHS,RDP,FRM,s<CR><LF>

Return message: None.

Parameter	Description	Range
s	Thales radio frame status	NONE or THL

See also:

\$PASHQ,RDP,FRM<CR><LF>

Example:

\$PASHS,RDP,FRM,NONE<CR><LF>

(Turns Thales radio frame off)

RDP,LOD

Function: Loads radio parameters.

Command:

\$PASHS,RDP,LOD,c<CR><LF>

Return message: None.

Parameter	Description	Range
c	Port connected to the radio	A, B, D

See also:

\$PASHS,RDP,LOD,c<CR><LF>

\$PASHS,RDP,PRG,c<CR><LF>

Example:

\$PASHS,RDP,LOD,D<CR><LF>

(Loads radio parameters through Port D)

RDP,LSP

Function: Sets the radio link speed.

Command:

\$PASHS,RDP,LSP,d<CR><LF>

Return message: None.

Parameter	Description	Range
s	Radio link speed	4800, 9600, 19200

See also:

\$PASHS,RDP,LOD,c<CR><LF>

\$PASHS,RDP,PRG,c<CR><LF>

\$PASHS,RDP,SST,s<CR><LF>

\$PASHS,RDP,CHN,d<CR><LF>

Comment: This command is only for PDL radios.

Example:

\$PASHS,RDP,LSP,9600<CR><LF>

(Sets PDL radio link speed to 9600 bps)

RDP,OFF

Function: Powers off the internal radio.

Command:

\$PASHS,RDP,OFF<CR><LF>

Return message: None.

See also:

\$PASHS,RDP,LOD,c<CR><LF>

\$PASHS,RDP,PRG,c<CR><LF>

Example:

\$PASHS,RDP,OFF<CR><LF>

(Powers off the internal radio)

Comment: This command is only for the internal radio (radio receiver). External radio cannot be turned off using this command.

RDP,ON

Function: Powers on the internal radio.

Command:

```
$PASHS,RDP,ON<CR><LF>
```

Return message: None.

See also:

```
$PASHS,RDP,LOD,c<CR><LF>
```

```
$PASHS,RDP,PRG,c<CR><LF>
```

Example:

```
$PASHS,RDP,ON<CR><LF>
```

(Powers on the internal radio)

Comment: This command is only for the internal radio (radio receiver). External radio cannot be turned on using this command.

RDP,PRG

Function: Programs the radio with the user-set parameters.

Command:

```
$PASHS,RDP,PRG,c<CR><LF>
```

Return message: None.

Parameter	Description	Range
c	Port connected to the radio	A, B, D

See also:

```
$PASHS,RDP,LOD,c<CR><LF>
```

```
$PASHS,RDP,SST,s<CR><LF>
```

```
$PASHS,RDP,LSP,d<CR><LF>
```

```
$PASHS,RDP,CHN,d<CR><LF>
```

```
$PASHS,RDP,CHN,f<CR><LF>
```

Example:

```
$PASHS,RDP,PRG,D<CR><LF>
```

(Programs the radio through Port D)

RDP,SST

Function: Sets radio sensitivity.

Command:

\$PASHS,RDP,SST,s<CR><LF>

Return message: None.

Parameter	Description	Range
s	Radio sensitivity	"LOW", "MED", "HIG" or "OFF"

See also:

\$PASHS,RDP,LOD,c<CR><LF>

\$PASHS,RDP,PRG,c<CR><LF>

\$PASHS,RDP,LSP,d<CR><LF>

\$PASHS,RDP,CHN,d/f<CR><LF>

Comment: This command is only for PDL radios.

Example:

\$PASHS,RDP,SST,HIG<CR><LF>

(Sets PDL radio sensitivity to "high")

RDP,TYP

Function: Set radio type for loading/programming/power-off (radio) through serial command.

Command:

\$PASHS,RDP,TYP,s<CR><LF>

Return message: None.

Parameter	Description	Range
s	Radio type	"PDL" or "THL"

See also:

\$PASHS,RDP,LOD,c<CR><LF>

\$PASHS,RDP,PRG,c<CR><LF>

\$PASHS,RDP,OFF

Example:

\$PASHS,RDP,TYP,PDL<CR><LF>

(Sets radio type to Pacific Crest Radio)

REC

Function: Controls data logging. The available functions are: Start, Stop, No and Restart. The data files that can be logged are B-files, E-files and also W-files if the SBAS function has been activated.

Command:

\$PASHS,REC,c<CR><LF>

Parameter	Description	Range
c	'Y' Log data on the SD Card 'N' Do not log data on SD Card 'S' Stop data logging on SD Card 'R' Restart data logging on SD Card	Y / N / S / R

Return message: ACK or NAK

RT3,BAN

Function: Sets the antenna descriptor field which will be transmitted in RTCM3.0 messages #1007 and #1008.

Command:\$PASHS,RT3,BAN,s<CR><LF>

Parameter	Description	Range
S	Antenna descriptor string	Up to 32 characters

Return message:

\$PASHR,RT3,ACK

\$PASHR,RT3,NAK

See also:

\$PASHQ,RT3

Option required: Remote monitor option (M)

RT3,BAS

Function: Sets the Z-Max to operate as an RTCM3.0 differential base station.

Command:

\$PASHS,RT3,BAS,x<CR><LF>

Parameter	Description	Range
x	Port forwarding the differential data	A, B, C or D

Return message:

\$PASHR,RT3,ACK or

\$PASHR,RT3,NAK

See also:

\$PASHQ,RT3<CR><LF>

Option required: Remote monitor option (M)

RT3,OFF

Function: Disables the RTCM3.0 base differential mode.

Command:

\$PASHS,RT3,OFF<CR><LF>

Return message:

\$PASHR,RT3,ACK

\$PASHR,RT3,NAK

See also:

\$PASHQ,RT3

Option required: Remote monitor option (M)

RT3,POS

Function: Provides the lat-lon-height coordinates of the antenna reference point. These coordinates will be inserted into message type #1005 or #1006.

Command:

\$PASHS,RT3,POS,m1,c1,m2,c2,f1<CR><LF>

Parameter	Description	Range
m1	Latitude in degrees, decimal minutes (ddmm.mmmmmmm)	0-90.0
c1	North (N) or South (S)	N,S
m2	Longitude in degrees, decimal minutes (ddmm.mmmmmmm)	0-180.0
c2	East (E) or West (W)	E,W
f1	The ellipsoidal height in meters	±0-99999.999

Example:

\$PASHS,RT3,POS,3722.2912,N,12159.799821,W,15.25<CR><LF>

Return message:

\$PASHR,RT3,ACK

\$PASHR,RT3,NAK

See also:

\$PASHQ,RT3

Option required: Remote monitor option (M)

RT3,STI

Function: Sets the user station identification (user STID).

Command:

```
$PASHS,RT3,STI,d<CR><LF>
```

Parameter	Description	Range
d	User station identification ID	4 digits

Example:

```
$PASHS,RT3,STI,0145<CR><LF>
```

Return message:

```
$PASHR,RT3,ACK
```

```
$PASHR,RT3,NAK
```

See also:

```
$PASHQ,RT3
```

Option required: Remote monitor option (M)

RT3,TYP

Function: Enables the type and output rate of the message sent by the base station.

Command:

```
$PASHS,RT3,TYP,x,y<CR><LF>
```

Parameter	Description	Range
x	Message number: 1001 to 1008 or 1013	4 digits
y	Output rate in seconds	0.1, 0.2, 0.5, 1, 2, 3, 4, 5, 6, 10, 12, 15, 20, 30, 60 or 120 seconds

Example:

\$PASHS,RT3,TYP,1001,1<CR><LF>

(Asking for message #1001 to be issued every second)

Return message:

\$PASHR,RT3,ACK

\$PASHR,RT3,NAK

See also:

\$PASHQ,RT3

Option required: Remote monitor option (M)

RTC,WAT

Function: Specifies transmission time delay between Type 18 and Type 19 messages (or between Type 20 and Type 21 messages).

Command:

\$PASHS,RTC,WAT,d<CR><LF>

Return message: None.

Parameter	Description	Range
d	Time delay in milliseconds	d has to be less than the Type 18/19 (or 20/21) interval, and d % 1000 = 0.

Example:

\$PASHS,RTC,WAT,1000<CR><LF>

Sets 1-second transmission time delay between Type 18 and Type 19 (or Type 20/21).

Comment: This command is used only when the Thales radio is used for the data link and RTCM18/19 or RTCM 20/21 are used.

SBA

Function: Turns off SBAS satellites tracking.

Command:

\$PASHS,SBA,OFF<CR><LF>

Return message:

\$PASHR,SBA,ACK

\$PASHR,SBA,NAK

Comment: SBAS satellite tracking can be activated using \$PASHS,SBA,MAN (manual selection) or \$PASHS,SBA,AUT (auto selection).

SBA,AUT

Function: Allows you to set the number of channels in the Z-Max receiver that are dedicated to tracking SBAS satellites. By making this choice you also determine the way SBAS satellites are allocated to the Z-Max reception channels.

Command:

\$PASHS,SBA,AUT,n<CR><LF>

Parameter	Description	Range
n	Number of channels in the receiver that are dedicated to tracking SBAS satellites.	1 or 2

In the Z-Max, two channels may be used for tracking SBAS satellites.

Depending on the value you choose for n , the following will happen:

- If $n=1$ (one channel dedicated to SBAS), the dedicated channel will lock onto the first SBAS satellite it detects that presents good quality data.
- If $n=2$ (two channels dedicated to SBAS), the first channel will operate as when $n=1$. The second channel will operate differently:
 - It will first search for all the possible SBAS satellites that can be received from the receiver location
 - It will then choose to track the best one. The best SBAS satellite is the one offering the best availability of valid SBAS data. (This selection criterion does not rely on the prior analysis of the ephemeris and correction data provided by SBAS satellites.)

Example:

```
$PASHS,SBA,MAN,33>CR><LF>
```

Return message:

```
$PASHR,SBA,ACK
```

```
$PASHR,SBA,NAK
```

SBA,MAN

Function: Allows you to manually specify one or two of the SBAS satellites that the Z-Max can track through its dedicated channels.

Command:

\$PASHS,SBA,MAN,x1(,x2]<CR><LF>

Parameter	Description	Range
x1	Number of the SBAS satellite that will be tracked by channel 1	2 digits
x2	(Optional) Number of the SBAS satellite that will be tracked by channel 2	2 digits

Example:

\$PASHS,SBA,MAN,33>CR><LF>

Return message:

\$PASHR,SBA,ACK

\$PASHR,SBA,NAK

Comment: The following numbering rule is used for SBAS satellite numbers:

$$SBAS\ number = SBAS\ PRN - 87$$

Where *SBAS PRN* ranges from 120 to 138.

Query Commands

BAT

Function: Queries the receiver for the internal battery status.

Command:

```
$PASHQ,BAT,[c1]<CR><LF>
```

(c1 - Response is sent out through the specified com. port A..C)

Return message:

```
$PASHR,BAT,d1,d2,d3,d4,d5,d6*cc
```

Parameter	Description	Range
d1	d1 is the voltage in mV.	
d2	d2 is the average current in mA.	
d3	d3 is the consumed power in mW. Equal to d1×d2.	
d4	d4 is the average time to empty in minutes (If internal battery is not the current power source for Z-Max, this number is meaningless.)	
d5	d5 is the remaining capacity in mA hours. Roughly equal to d2×d4÷60	
d6	d6 is the internal battery status. Used for engineering troubleshooting only.	

See also:

```
$PASHQ,POW<CR><LF>
```

Example:

```
$PASHQ,BAT<CR><LF>
```

```
$PASHR,BAT,V:8030,I:399,W:3203,T:1236MIN,C:7794MAH,C:0xc0*55
```

BEEP

Function: Queries the receiver for beeper status.

Command:

\$PASHQ,BEEP<CR><LF>

Return message:

\$PASHR,BEEP,s*h<CR><LF>

Parameter	Description	Range
s	Beeper status	ON/OFF

MDM

Function: Returns the current modem parameter settings.

Command:

\$PASHQ,MDM[,c1]<CR><LF>

(c1-Response message is sent to the specified port A..D)

Option required: None.

Return message:

\$PASHR,MDM,port,baud,state,type,s1,s2,s3,s4,s5,s6,
PIN=s7,PHN=s8,BND=s9,ADL=s10,RNO=s11,LIP=s12,RIP=s13,
PTC=s14,IPT=s15,IPP=s16,APN,s17,LGN,s18,PWD,s19
<cs><CR><LF>

Return Parameters	Description	Range
port	Modem port	'A' - 'D'
baud	Modem baud rate	3 - 8
state	Modem state	OFF,ON,INIT,DIALING,ONLINE
type	Modem type index, 5 for GSM Cellular	0 - 5
s1	Initialization string	
s2	Configuration string	
s3	'to command mode' string	
s4	'to data mode' string	
s5	Hang up command	
s6	End of line indicator	CR, LF or CRLF
s7	Personal Identification Number	4 - 8 digits
s8	Base station phone number	1 - 20 digits
s9	GSM band	1900 or 800/1600
s10	Auto dial mode	'Y' or 'N'
s11	Max number or redial attempts	0 - 15
s12	Local IP address	0-15 digits
s13	Remote IP address (base or caster)	0-15 digits
s14	Protocol used for GSM link	0-1
s15	Type of Internet protocol used	UDP or TCP
s16	IP port number used for point-to-point connection	1-65535
s17	APN (Access Point Name) used for the GPRS connection	Up to 32 characters, case-sensitive
s18	LGN: user name provided by GPRS operator	Up to 32 characters, case-sensitive
s19	PWD: password provided by GPRS operator	Up to 32 characters, case-sensitive
cs	checksum	

See also:

\$PASHS,MDM,PAR,...<CR><LF>

Example:

\$PASHR,MDM,D,6,OFF,5,AT&F0V1X4E0,ATS0=1,+++,ATO,ATH,CR LF,PIN=123456,PHN=1112222,BND=1900,ADL=N,RNO=0*67

MDM,LVL

Function: Returns the current value of modem signal level.

Command:

\$PASHQ,MDM,LVL,[c1]<CR><LF>
(c1-Response message is sent to the specified port A..D)

Option required: None

Return message:

\$PASHR,MDM,LVLlevel <cs><CR><LF>

Return Parameters	Description	Range
level	Signal level	-1: Information not available 0-5: current value of signal level

Example:

\$PASHR,MDM,LVL,2*67

Comment: This command can only be used in GSM CSD data mode.

MDP

Function: Returns Port B's communication mode status.

Command:

\$PASHQ,MDP,[c1]<CR><LF>
(c1 -Response message is sent to the specified com. port A..D)

Return message:

\$PASHR,MDP,B,s*h

Return Parameters	Description	Range
s	Port B's communication mode	"RS422" or "RS232"

See also:

\$PASHS,PRT,B,s,<CR><LF>

Example:

\$PASHR,MDP,B,RS232*5D<CR><LF>

NTR

Function: Returns the current NTRIP parameter settings.

Command:

```
$PASHQ,NTR,[c1]<CR><LF>
```

(c1-Response message is sent to the specified port A..D)

Option required: None

Return message:

```
$PASHR,NTR,LGN=s1,PWD=s2,ADD=d1,PRT=d2 <cs><CR><LF>
```

Return Parameters	Description	Range
s1	Login string required to access the caster	32 characters max.
s2	Password string required to access the caster	32 characters max.
d1	Caster IP address in the form: "xxx.xxx.xxx.xxx"	4-15 digits
d2	Number of the IP port used to access the caster	0-65535

See also:

```
$PASHS,NTR,PAR
```

Example:

```
$PASHR,NTR,LGN=integtest,PWD=password,  
ADD=81.255.195.106,PRT=2101*67
```

NTR, TBL

Function: Returns the source table used for the current caster.

Command:

```
$PASHQ,NTR,TBL<CR><LF>
```

Example:

```
$PASHQ,NTR,TBL<CR><LF>
```

Return message: As specified in the RTCM recommended standard for Networked Transport of Internet Protocol (NTRIP) Version 1.0 - September 30, 2004.

```
$PASHR,NTR,
SOURCE:TABLE 200 OK
Content-Type: text/plain
Content-Length: 7864
CAS:129.217.182.51:80:ICD:BKG:0:GER:51.5:7.5:Triol Broadcaster
NET:GREF:BKG:B:N:http://igs.ifaag.de/GREF.htm:none:denise.dettmering@bkg.bund.de:none
NET:IGS-IGLOS:BKG:B:N:http://igs.cb.jpl.nasa.gov/projects/rtwg/:none:denise.dettmering@bkg.bund.de:none
STR:FFMJ2:Frankfurt:RTCM 2.0:1(1),3(19),16(59):0:GPS:GREF:GER:50.12:8.68:0:1:GPSNet V1.9:none:N:N:560:Demo
STR:FFMJ1:Frankfurt:RTCM 2.1:3(19),16(59),18(1),19(1):2:GPS:GREF:GER:50.09:8.66:0:0:GPSNet V1.9:none:N:N:2800:Demo
STR:FFMJ0:Frankfurt:RAW:Compact(1):2:GPS+GLO:IGS-IGLOS:GER:50.09:8.66:0:0:Javad Legacy E:none:N:N:3600:Demo
STR:LEIJ0:Leipzig:RAW:Compact(1):2:GPS+GLO:IGS-IGLOS:GER:51.33:12.37:0:0:Javad Legacy E:none:B:N:3600:none
STR:WITZ0:Witz:RAW:Compact(1):2:GPS+GLO:IGS-IGLOS:GER:49.13:12.88:0:0:Javad Legacy E:none:B:N:3600:none
STR:HEIJ0:Helgoland:RAW:Compact(1):2:GPS+GLO:IGS-IGLOS:GER:54.18:7.88:0:0:Javad Legacy E:none:B:N:3600:none
STR:TITZ0:Titz:RAW:Compact(1):2:GPS+GLO:IGS-IGLOS:GER:51.00:6.42:0:0:Javad Legacy E:none:B:N:3600:none
STR:HUEG0:Hueselheim:RAW:Compact(1):2:GPS+GLO:IGS-IGLOS:GER:47.82:7.62:0:0:Javad Legacy E:none:B:N:3600:none
STR:DREJ0:Dresden:RAW:Compact(1):2:GPS+GLO:IGS-IGLOS:GER:51.05:13.73:0:0:Javad Legacy E:none:B:N:3600:none
STR:SASS0:Sassnitz:RAW:Compact(1):2:GPS+GLO:IGS-IGLOS:GER:54.51:13.64:0:0:Javad Legacy E:none:B:N:3600:none
STR:KARJ0:Karlsruhe:RAW:Compact(1):2:GPS+GLO:IGS-IGLOS:GER:49.01:8.41:0:0:Javad Legacy E:none:B:N:3600:none
STR:WILH0:Wilhelmshaven:RTCM 2.0:1(1),3(19),16(59):0:GPS:GREF:GER:53.52:8.10:0:1:GPSNet V1.9:none:N:N:560:VRS
ENDSOURCE:TABLE
```

RDP

Function: Returns the current UHF radio parameters.

Command:

\$PASHQ,RDP,[c1]<CR><LF>

(c1 -Response message is sent to the specified com. port A..D)

Return message:

PDL radio:

\$PASHR,RDP,s1,d1,d2,f1,f2,c1,d3,s2,c2*h

Thales radio:

In the US: \$PASHR,RDP,s1,d1,d2,f1,d3,s2,c1*h

In Europe: \$PASHR,RDP,s1,d1,f1,d2,s2,c1*h

PDL radio:

Return Parameters	Description	Range
s1	Radio type	PDL
d1	Radio/receiver interface baud rate	bps: 1200, 2400, 4800, 9600, 19200, 38400
d2	Current channel index	00-15
f1	Current channel's receive frequency	410-470 MHz
f2	Current channel's transmit frequency	410-470 MHz
c1	Digisquelch/sensitivity	H: high M: medium L: low O: off
d3	Link speed	4800, 9600, and 19200 bps
s2	Serial number	
c2	Port connected to the radio	A,B,D
H	Checksum	

Thales Radio, in the US:

Return Parameters	Description	Range
s1	Radio type	THL
d1	Radio/receiver interface baud rate	19200 bps, fixed
d2	Current channel index	0-15, if the frequency can be found in the channel table; 16, frequency cannot be found in the channel table
f1	Current frequency	410-470 MHz
d3	Link speed	4800 bps, fixed
s2	Version	RUHFV*****: receiver; EUHFV*****: transmitter
c1	Port connected to the radio	A,B,D
H	Checksum	

Thales Radio, in Europe:

Return Parameters	Description	Range
s1	Radio type	THL
d1	Radio/receiver interface baud rate	19200 bps, fixed
f1	Current frequency	410-470 MHz
d2	Link speed	4800 bps, fixed
s2	Version	RUHFV*****: receiver; EUHFV*****: transmitter
c1	Port connected to the radio	A,B,D
H	Checksum	

See also:

\$PASHQ,RDP,USR

Examples:

Query: \$PASHQ,RDP<CR><LF>

Response: \$PASHR,RDP,PDL,19200,00,464.5000,00.0000,H,9600,
1094221,D*55<CR><LF>

Query: \$PASHQ,RDP<CR><LF> (US)

Response: \$PASHR,RDP,THL,19200,00,464.5000,4800,RUHFV20100,
D*69<CR><LF>

Query: \$PASHQ,RDP<CR><LF> (Europe)

Response: \$PASHR,RDP,THL,19200,464.0000,4800,EUHFV10300,
B*50

Comment: If the radio has never been loaded or the most recent loading was unsuccessful, the query will just return the radio type selected by the user.

Example:

```
$PASHQ,RDP
$PASHR,RDP,PDL*6A
```

RDP,CHT

Function: Returns the radio channel table.

Command:

```
$PASHQ,RDP,CHT[c1]<CR><LF>
```

(c1 -Response message is sent to the specified com. port A..D)

Return message:

```
$PASHR,RDP,CHT,s,d1,{d2,f1,f2}n*h
$PASHR,RDP,CHT*h
```

See also: None

Comment: If the radio has not been loaded or the radio is has no channel table (Thales radio for European customer), the response will be Format 2.

Examples:

Query: \$PASHQ,RDP,CHT<CR><LF>

Response: \$PASHR,RDP,CHT,PDL,02,00,464.5000,
0.0000,01,464.5500, 0.0000*3B

Query: \$PASHQ,RDP,CHT<CR><LF>

Response: \$PASHR,RDP,CHT,THL,02,00,444.0000,
0.0000,01,444.5500, 0.0000*36

Query: \$PASHQ,RDP,CHT

Response: \$PASHR,RDP,CHT*65

RDP,FRM

Function: Returns Thales radio's frame status.

Command:

\$PASHQ,RDP,FRM[c1]<CR><LF>

(c1 -Response message is sent to the specified com. port
A..D)

Return message:

\$PASHR,RDP,FRM,s*h

Return Parameters	Description	Range
s	Thales radio frame status	"ON", "OFF"
h	Checksum	

See also:

\$PASHS,RDP,FRM,s<CR><LF>

Example:

Query: \$PASHQ,RDP,FRM,<CR><LF>

Response: PASHR,RDP,FRM,THL,OFF*7C

RDP,TYP

Function: Returns the radio type selected by the user through the serial command or the radio type determined by the front panel loading process, whichever goes last.

Command:

\$PASHQ,RDP,TYP[c1]<CR><LF>

(c1 -Response message is sent to the specified com. port A..D)

Return message:

\$PASHR,RDP,TYP,s*h

Return Parameters	Description	Range
s	Radio type	"PDL" or "THL", default is "THL"
h	Checksum	

See also:

\$PASHS,RDP,TYP,s<CR><LF>

Example:

Query: \$PASHQ,RDP,TYP<CR><LF>

Response: \$PASHR,RDP,TYP,THL*1B

RDP,USR

Function: Returns the user's current setting after successful loading.

Command:

\$PASHQ,RDP,USR[c1]<CR><LF>

(c1 -Response message is sent to the specified com. port A..D)

Return message:

PDL radio:

\$PASHR,RDP,USR,s1,d1,f1,f2,c1,d2,c2*h

Thales radio:

In the US: \$PASHR,RDP,USR,s1,d1,f1,c1*h

In Europe: \$PASHR,RDP,USR, s1,f1,c1*h

PDL radio:

Return Parameters	Description	Range
s1	Radio type	PDL
d1	Channel index set by user	00-15
f1	Receive frequency of user-selected channel	410-470 MHz
f2	Transmit frequency of user-selected channel	410-470 MHz
c1	Digisquelch/sensitivity set by user	H: high M: medium L: low O: off
d2	Link speed set by user	4800, 9600, 19200 bps
c2	Port connected to the radio	A, B, D
<i>h</i>	Checksum	

Thales Radio:

In the US:

Return Parameters	Description	Range
s1	Radio type	THL
d1	Channel index set by user	d1 = 0-15, if the frequency can be found in the channel table. d1 = 16, when radio is loaded, its frequency cannot be found in the channel table, and user hasn't set the channel number yet.
f1	Frequency of user-selected channel	410-470 MHz
c1	Port connected to the radio	A, B, D
h	Checksum	

In Europe:

Return Parameters	Description	Range
s1	Radio type	THL
f1	Radio frequency set by user	410-470 MHz
c1	Port connected to the radio	A, B, D
h	Checksum	

See also:

\$PASHQ,RDP

Examples:

Query: \$PASHQ,RDP,USR<CR><LF>

Response: \$PASHR,RDP,USR,PDL,00,464.5500,464.5500,O,
4800,B*1B

Query: \$PASHQ,RDP,USR<CR><LF>

Response: \$PASHR,RDP,USR,THL,00,464.0000,B*64

Query: \$PASHQ,RDP,USR

Response: \$PASHR,RDP,USR,THL,16,464.0000,B*63

Query: \$PASHQ,RDP,USR<CR><LF>

Response: \$PASHR,RDP,USR,THL,464.0000,B*48

Comment: If the radio has never been loaded or the most recent loading was unsuccessful, the query will just return the radio type selected by the user.

Example:

\$PASHR,RDP,USR,PDL*1A

RT3

Function: Returns information about the RTCM3.0 settings.

Command:

\$PASHQ,RT3<CR><LF>

Return message:

The returned message consists of five lines:

- First line:
Always RTCM 3.0 SETUP:
- Second line:
MODE:a PORT:b STI :c ANT :d
Where:

Return Parameters	Description	Range
A	Current RTCM3.0 mode	0: OFF / 1:ON
B	Port identification	A,B, or D
C	Reference station ID	4 digits
D	Antenna descriptor field	Up to 32 characters

- Third line:
TYPE: 01 02 03 04 05 06 07 08 09 10 11 12 13
Where 01 means message 1001, 02 means message 1002, and so on.
- Fourth line:
FREQ: 00 00 00 00 00 1.0 00 00 00 00 00 00
Where each two-figure number gives the output rate, in seconds, of the corresponding message type.

- Fifth line:

BASE: 0000.00000,S,00000.00000,W,0.000

This line contains the base position as defined by the PASHS,RT3,POS command. (Latitude and longitude are expressed in “ddmm.mmmmm” format and altitude in meters.)

Example:

```
RTCM 3.0 SETUP:
MODE:0 PORT:A STI:0888 ANT:Doring morgulin
TYPE: 01 02 03 04 05 06 07 08 09 10 11 12 13
FREQ: 00 00 00 00 00 1.0 00 00 00 00 00 00 00
BASE: 5539.14269,S,03729.88358,E,232.120
```

WARN

Function: This command queries the receiver for any warning messages, where c is the optional output port.

Command:

```
$PASHQ,WARN,c<CR><LF>
```

Return message:

```
$PASHR,WARN,s1,s2*h
```

Example:

```
$PASHR,WARN, GPRS session failed,'PENDING'*50
$PASHR,WARN, Ntrip caster connection failed, 'CURRENT' *57
```

Return Parameters	Description	Range
S1	Warning message: NONE= no warnings	For a list of new warning messages, refer to the table below.
S2	Status: Pending = has been acknowledged Current = has not been acknowledged Occurred = Error occurred, but did not persist.	'PENDING', 'CURRENT', 'OCCURRED'

The table below summarizes the current warning messages that may be included in the return message, if relevant.

Warning messages	Definition	Action
GPRS session failed	Cannot open a GPRS session	Check that the GPRS service is open with your SIM card. Check APN parameters (APN, user name, and password)
Mailbox file not found	The mailbox file does not exist	Check the name of the base
ftp session failed	Cannot reach the FTP site	Check FTP parameters (IP address, username, and password)
Connection to the base failed	Cannot reach the base	Check if the base is ON
NTRIP caster connection failed	Cannot reach the caster server	Check NTRIP caster parameters (IP address, port number, username and password)

WARN,MDM

Function: Returns the current warning setting for GSM.

Command:

\$PASHQ,WARN,MDM<CR><LF>

Return message:

\$PASHR,WARN,MDM,a,b,c*h

A repeat of \$PASHR,WARN for all the pending errors and warnings.

Examples:

\$PASHR,WARN,MDM,1,2,3*55

\$PASHR,WARN,MDM,2,2,4*57

Return Parameters	Description	Range
a	Current line number	1-10
b	Total number of lines	1-10
c	Warning number	0-32 0: no warning 1: Modem not detected 2: Modem not responding 3: Modem initialization error 4: Enter phone number 5: Modem no carrier 6: Modem line busy 7: Modem insert SIM card 8: Modem invalid Pin 9: Modem SIM card lock 10: Modem SIM card Failure

9. Using An External CDMA Modem

Introduction

This chapter describes the procedure to connect the Z-Max.Net unit to an Airlink Raven CDMA modem C3210.

The purpose is to connect a Z-Max.Net rover via a CDMA modem to an iCGRS base, or any other base or base caster that can be accessed via an IP address. In this chapter, the term “base” will be used to refer to any of these Internet-enabled base systems.

To operate the modem mentioned above, you should use the Thales kit P/N 990572-01 including the following items:

- Power cable S/N 702079 used to power the external modem from the external battery also part of the kit (see below)
- Serial cable S/N 702078 used to connect the external modem to port A on the Z-Max.Net unit.
- Li-Ion Battery S/N 110284
- Smart, dual-slot battery charger S/N 110049
- Backpack S/N 205044

The interconnection diagram below shows how the raven modem interfaces with Z-Max.Net.

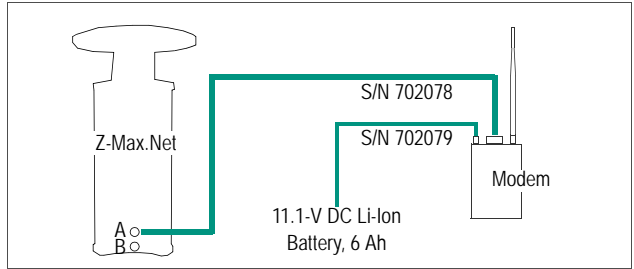

Note: Z-Max.Net connector pinouts are described on *page 262*.

Activating the Modem

This procedure allows you to register the modem with the chosen wireless operator. It should be done in priority before doing anything else. It is required only the first time you use the modem.

Before activating the modem, make sure the following items are available:

- PC computer with Windows XP or 2000
- CDMA Raven modem for Verizon C3210, its antenna and a power source
- Serial cable for connection between modem and PC
- *Airlink Setup Wizard* software for the Verizon Wireless operator

You can download this software from the Airlink website (<http://www.airlink.com/support/modems/utilities/#ace>).

Note that at the time when you need to perform the download, the Airlink web page from which you can download the software may be different from the one mentioned above. In that case, please search for the desired link on the Airlink web site.

Depending on whether Microsoft® .NET Framework 1.1 (or later) is already installed on your computer, do the following:

- Download *SetupWizard1.zip* if you already have .NET installed on your computer
 - Otherwise download *SetupWizard2.zip*.
- Phone number provided by the operator. The operator will have been able to provide this number on reception of the ESN number printed on the label of your modem.

Do the following to activate the modem:

1. Connect the modem to the PC through the serial cable
2. Connect the power source and the antenna to the modem
3. Unzip the exe file contained in the zip file you have downloaded from the Airlink Web site.
4. Run the exe file to install the software. Follow the instructions given by the installation procedure.
5. Run the Setup Wizard software.
6. In the welcome window, clear the “Setup a DUN Connection” check box and then click on the Next> button



7. Select the serial port the modem is connected to and then click on the Next> button
8. Read the ESN number displayed in the window and check that it is the same number as the one printed on the modem label. Then click on Next>
9. Skip the next screen by directly clicking on the Next> button
10. Enter the MSL code (“000000” for Verizon Wireless) and then click on the Next> button
11. In the MDN field, enter the phone number provided by the operator and then click on the Next> button.
12. Unless the operator gave you the SID and NID numbers, skip the current screen by clicking on the Next> button.
13. Unless the operator gave you the NAI and password parameters, skip the current screen by clicking on the Next> button
14. Select “Automatic B” in the Preferred Service System field and then click on the Next> button
15. Click on the Test button in the center of the dialog
16. Check that the firmware version has successfully been updated and then click Next>
17. Select the Public Internet option and then click Next>
18. Check that the “Your PRL list is up-to-date” message is now displayed then click Next>. If the PRL list has not been updated, click on the Update button.
19. Let the program test the modem (this may take a while). On test completion, you should read “Congratulations. Your modem is properly configured”. Click Finish to quit the program.
20. Now proceed with the installation of the rover modem.

Installing the Rover Modem

Before using the modem, the Z-Max.Net and modem must be configured so that the connection to the base be automatic when powering up the modem.

Configuring the modem

The following equipment and software are required:

- A computer equipped with a serial port
- An Airlink raven modem (GPRS or CDMA) and its antenna
- A serial cable used to connect the modem to the computer
- A power source for the modem (see Raven modem accessories)
- The public IP address and port number for the base
- *Wireless ACE 3G* software installed on the computer. This software can be downloaded for free from the Airlink web site. On April 2006, you can find *Wireless ACE 3G* (version v20060112) on web page <http://www.airlink.com/support/modems/utilities/>. Note that at the time when you need to perform the download, the Airlink web page from which you can download the software may be different from the one mentioned above. In that case, please search for the desired link on the Airlink web site.

Warning! *Wireless ACE 3G* requires that Microsoft® .NET Framework 1.1 (or later) be installed on the computer. For more information on this topic, go to <http://www.airlink.com/support/dotnet.asp>

Assuming .NET Framework 1.1 or later has been installed on your computer, unzip the downloaded file, run the exe file and install the software as instructed.

Follow the instructions below:

- Connect the modem to COM1 on the PC using the serial cable supplied

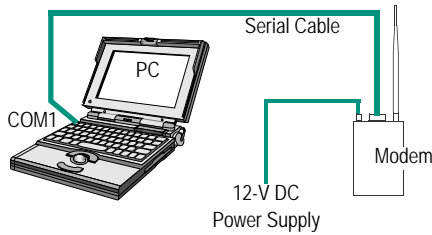

- On the office PC, run *WirelessAce 3G*. In what follows, version v20060112 is described. You may have downloaded a different version.
- Click on the Connect button in the menu bar
- Select “PPP” in the list on the left and select “COM1” as the port used on PC side
- If the password field is already filled, leave it as is. If it’s blank, enter the default password (“12345”)

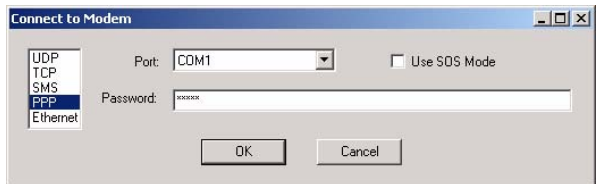

- Click OK. A new dialog box opens.

- In the vertical menu on the left, click on “Misc”:

GROUPS	MODEM DATA			PRINTAB
----- INFO	AT	Name	Value	New Value
----- STATUS	*DATE	Date and Time	04/24/2006 11:40:40	
----- COMMON	*OPRG	Enable Over-the-Air Programming	1	
----- Misc	*PHONE	Phone Number	9097625420	
----- Serial	*STATICIP	Force Static IP	0.0.0.0	
----- TEP	*DPORT	Device Port	6666	
----- DNE	*NETUID	Network User ID	9097625420@vzw3g.com	
----- Dynamic IP	*NETPW	Network Password	vzw	
----- PPP/Ethernet	*HOSTPAP	Request PAP	0	
----- PassThru	S53	Destination Address		
----- SMTP	S53	Destination Port	0	
----- Other	S53	Default Dial Code	T	
----- Low Power				
----- Friends				
----- LOGGING				
----- CDMA				

- Enter the following parameters on this screen:
 - S53 / Destination address: Enter the base IP address (this address should have been sent to you by the base administrator)
 - S53 / Destination Port: Enter the base port number (again,
 - S53 / Default dial code: Choose “T-TCP”
- In the vertical menu on the left, click on “Serial” and then define the following parameter:
 - S211 / DTR Mode: Choose “1-Ignore DTR”
- In the vertical menu on the left, click on “TCP” and then select the following parameter:
 - TCPT / connection time out (in minutes): Enter “1”
 - TCPS / connection time out unit: Choose “0-Minutes”
- In the vertical menu on the left, click on “UDP” and then select the following parameter:
 - MD / Startup Mode Default: Choose “04-TCP”
- Click on the “Write” button in the menu bar to save these parameters to the modem. The modem is now ready for use.

Configuring the Z-Max.Net Unit

The following equipment is required:

- A field terminal running FAST Survey
- A Z-Max rover
- A power source for the Z-Max (power module or external power source)

Follow the instructions below:

- Run FAST survey
- Establish communication with the Z-Max via the chosen link (Bluetooth or serial cable).

If you choose Bluetooth, then you can connect the modem either to port A or port B on the Z-Max.Net unit as communication from the field terminal uses port C.

If you use port B, you will have to make sure the port is currently set as an RS232 port (see commands involved in the procedure below).

In what follows, it is assumed that Bluetooth is used for communication between the field terminal and the Z-Max.Net and port A is used to connect the modem to the Z-Max.Net (see diagram below).

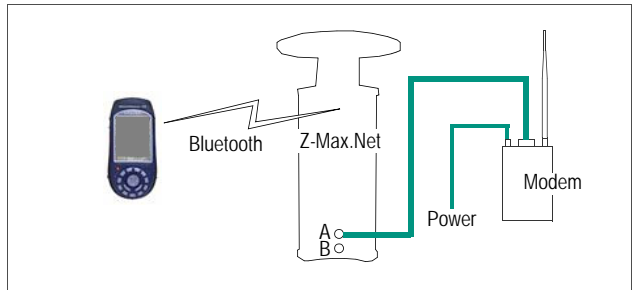

- Tap on the Equip tab
- Tap Receiver Utilities
- Tap Send Command to Receiver
- From the displayed screen, send the following commands to the Z-Max (tap OK after typing in each command):

Command	Response	Comments
\$PASHS,SPD,A,9	\$PASHR,ACK	Set port A to 115.2 kbps
\$PASHS,PRT,A,232	\$PASHR,ACK	Set port A to RS232 mode
\$PASHS,NME,GGA,A,ON	\$PASHR,ACK	Send GGA message to port A in order to initiate the connection to the base
\$PASHS,SAV,Y	\$PASHR,ACK	Save this configuration to Z-Max.Net

Note: The commands can also be sent from a computer using a serial cable between the Z-Max.Net and the computer and running WinComm or Windows' Hyperterminal utility. See also *Applying Serials Commands to Z-Max.Net on page 171* for more information.

After sending all these commands, the modem is ready for use and you can start using your Z-Max.Net rover in the field. RTK correction data will be received on port A.

Hang-up

Just disconnect the Airlink Raven modem from its power source.

Troubleshooting

Symptoms	Action
Z-Max.Net is not responding	Check the cable or Bluetooth link Check baud rates
No response after dialing a Z-Max.Net base phone number	Check antenna connection to modem Using a cell phone, check that the area is properly covered by the chosen operator Check power and base configuration Check that Z-Max.Net is not already on-line
No response after dialing an iCGRS station phone number	Check antenna connection to modem Using a cell phone, check that the area is properly covered by the chosen operator Check station IP and port parameters Check that Z-Max.Net is not already on-line
Frequent disconnection from the base	Check antenna connection to modem
No response to the AT command	Check baud rate on port A (should be 115.2 kbps) Check modem power input (+12 V DC). Should be between 10 and 28 V DC

10. Troubleshooting

Receiver is Not Tracking Satellites

	RTK Base	RTK Rover	PP Base	PP Rover
Relevant to	●	●	●	●

Step 1. Is the Receiver Powered Up?

To determine if the receiver is powered up, examine the power LED on the front panel of the receiver. If the LED is on (red or green), the receiver is on.

1. *If the receiver is not powered up*, turn on the receiver by pressing and holding the power switch on the left side of the Z-Max.Net front panel. The button must be held for a few seconds since there is a delay in power on. You will see the power LED turn on and the display will begin to show text.
2. *If the receiver does not power up*, check the power source. The Z-Max.Net supports both internal (power module) and external power sources.
 - If using the power module, press the power level indicator button. If low, replace the module with a good one and turn on the receiver.
 - If using external power, check to ensure the power cable is properly connected to both the battery and the receiver.
 - If the cable is properly connected, check the power level of the external power source. If low, replace the battery with a charged battery and turn on the receiver.

- If the external power source is good and the cable is connected to both the receiver and the power source, there may be a problem with the cable. If available, try a different power cable. If the new cable works, the old cable is malfunctioning. Call your local dealer or email Thales technical support for assistance.
 - You may have a malfunctioning GPS receiver. Call your local dealer or email Thales technical support for assistance.
3. *If the receiver is powered up, go to Step 2 below.*

Step 2. Is the GPS Antenna Connected to the Receiver?

Look at the GPS antenna module on top of the receiver module.

1. *If the antenna module is not connected to receiver, do it now:*
 - Insert the antenna module into the antenna receptacle at the top of the receiver module. Make sure the base of the antenna module is oriented so that the flattened area is lined up with the flattened area of the receptacle, and the module will easily slide into place.
 - Once in place, twist the threaded collar on the antenna module until the antenna is securely locked in place.
 - Once connected, give the GPS receiver a few seconds to lock onto satellites.
2. *If the antenna module is connected to the receiver, ensure proper connection.*
 - The antenna module must be securely locked into place on top of the receiver module. Ensure this is the case.
 - Ensure the threaded collar on the antenna module is tight and not cross threaded.
3. *If the problem is not yet resolved, go to the next step.*

Step 3. A Component May Be Malfunctioning

You may have a malfunctioning antenna module. Follow these steps to help isolate which component is causing the problem.

1. Replace the GPS antenna module with the one from your other system, if you have one. If the receiver locks onto satellites, there is a problem with the antenna module. Contact your local dealer or email Thales technical support for assistance.

Step 4. You May Have a Malfunctioning GPS Receiver

Call your local dealer or email Thales technical support for assistance.

Receiver is Not Recording Data

	RTK Base	RTK Rover	PP Base	PP Rover
Relevant to	○	○	●	●

The Data Log LED on the front panel of the receiver module will blink green each time an epoch of data is recorded to memory. Examining this LED, you determine that the receiver is not logging data to memory. Follow the procedures below to determine the cause of this problem.

Step 1. Is the GPS Receiver Tracking Satellites?

The GPS receiver must first be tracking satellites before it can log data to memory. Check the SV/Power LED on the front panel of the receiver module to determine if the receiver is tracking satellites.

- *If the receiver is not tracking satellites*, refer to *Receiver is Not Tracking Satellites* on page 225 to try and determine the problem.
- *If the receiver is tracking satellites*, go to step 2 below.

Step 2. Is the SD Memory Card Installed in the GPS Receiver Module?

The Z-Max.Net receiver logs data to a removable SD data card. The data card must be installed in the Z-Max.Net GPS receiver module for the receiver to log data. Check to ensure that the data card is properly installed. If the Z-Max.Net is powered on without a data card, a warning message should appear across the front panel display.

- *If the data card is absent*, install one into the receiver.
- *If a data card is installed*, go to step 3 if the problem is not yet resolved.

Step 3. Is the Data Card Full?

The Data log LED will be solid red if the data card in the receiver is full. Check the LED to determine if the card is full.

- *If the card is full*, delete some of the data files on the data card that have been downloaded or insert another SD card that has available memory remaining.
- *If the card is not full*, replace the current SD data card with another card. If data recording begins after replacing the data card, then there is a problem with the original data card.
- If the problem is not yet resolved, go to step 4.

Step 4. Has Data Recording Been Turned Off?

The receiver contains a “Stop Session” function that is used to suspend data recording to change data cards. Once a Stop Session has been issued, a “Start Session” is required to resume data collection. Also, it is possible using FAST Survey to turn data recording off.

- Perform the following one of the following two steps to ensure data recording is enabled:
 1. On the front panel display, go to the SESSIONS submenu and perform a START SESSION.

2. Using the field terminal and FAST Survey, make sure that data recording is enabled: Tap on the Surv tab, then on 7 Log Static Data and check that Start File is dimmed and the status is File: Logging...
- If the problem is not yet resolved, go to step 5.

Step 5. A Component May Be Malfunctioning

You may have a malfunctioning GPS receiver. Contact your local dealer or email Thales Technical Support for assistance.

Base Radio is Not Transmitting Data

	RTK Base	RTK Rover	PP Base	PP Rover
Relevant to	●			

The Communication LED on the front panel will blink green each time a packet of good quality data is transmitted. After examining this LED, you find that the base system is not transmitting data. Follow the outline below to troubleshoot this problem.

Step 1. Is the Base Radio Powered Up?

To determine if the base radio is on, examine the power LED on the front panel of the radio. If the LED is on (green or red, steady or flashing), the radio is on. Note that the Thales radio does not have a power LED and can be powered from a 9- to 15-V DC power source.

1. *If the base radio is not powered up:*
 - As both the Thales and the PDL radios automatically turn on once power is applied, if using one of the UHF radios and power is supplied by an external power source, check to ensure that the power cable is connected to both the radio and the power source.
 - If you find the cable properly connected, check the power level of the power source. If low, charge the battery or replace it with a charged one and connect it to the radio.

- Check to ensure that the cable connecting the radio to the receiver is connected properly. It is recommended that the radio be connected to the port labeled 'B' on the Z-Max.Net.
- If the cable is properly connected, check that the receiver is turned on.
- If still no power, disconnect the cable at the receiver and connect to another RS-232 port. If the radio powers up, there is a problem with the RS-232 port you were previously connected. Avoid this port until you can arrange to have it fixed.
- You may have a malfunctioning radio or radio power cable. If using the Pacific Crest UHF radio, it is not possible to further isolate the problem. Contact your local dealer or email Thales technical support for assistance.

2. *If the base radio is powered up, go to step 2 below.*

Step 2. Is the Base Radio Connected to the GPS Receiver?

In order for the base radio to transmit data, it must receive the data from the base receiver. To determine if the radio is connected to the receiver, look for a cable connecting the two components.

1. *If the radio is not connected to the receiver:*
 - Connect the base radio to the Z-Max.Net.
 - On the back panel of the Z-Max.Net, connect the radio cable to port B.
 - Connect the radio cable to the radio connector labeled DATA/PWR or SERIAL.
2. *If the radio is connected to receiver:*
 - Ensure proper connection
 - Ensure that the radio cable is connected to port B on the rear panel of the receiver.
 - Ensure the connection between the receiver and the radio is well-seated.
3. *If the problem is not yet resolved, go to step 3.*

Step 3. Is the Base Set to Function as RTK Base?

If the base receiver is not set to RTK base mode, it will not send raw data to the serial port for transmission by the radio. Use FAST Survey or the Z-Max.Net front panel to determine if the receiver is set to RTK base mode.

1. *If the receiver is not configured as an RTK base:*
 - Set the receiver to RTK base mode using either FAST Survey or the -Max.Net front panel (see *Configuring the RTK Base on page 41*).
2. *If the receiver is configured as an RTK base, go to step 4 below.*

Step 4. Is the Receiver Set to Output RTK Correction Data on Port B?

The port set in the GPS receiver for output of RTK correction data must be the same port to which the base radio is connected. The base radio should currently be connected to the serial port labeled 'B' on the back of the Z-Max. Use FAST Survey or the Z-Max.Net front panel to verify that port B is set as the output port for RTK correction data.

1. *If the receiver not set:*
 - Set the receiver to output RTK base data on port B using either FAST Survey or the Z-Max.Net front panel (see *Configuring the RTK Base on page 41*).
2. *If the receiver is set, go to step 5 below.*

Step 5. Base Coordinates Entered Correctly Into Base Receiver?

The base GPS receiver compares the position it computes for its location to the position entered by the user as the base position. If the two sets of coordinates differ by more than 500 meters, the base receiver will not output RTK correction data. Use FAST Survey or the Z-Max.Net front panel to verify the coordinates entered for the base position.

1. *If the coordinates are not entered correctly:*
 - Set the correct base system position using either FAST Survey or the Z-Max.Net front panel.
2. *If the coordinates were entered correctly, go to step 6 below.*

Step 6. Is the Base Receiver Tracking Satellites?

The base receiver must be tracking satellites in order to collect the data required for the radio to transmit. If the base receiver is not tracking at least 4 healthy satellites, no data will be sent to the radio. Use either the Power/SV LED on the front panel of the receiver or FAST Survey to determine if the base receiver is tracking 4 or more satellites.

1. *If the receiver is not tracking satellites, See Receiver is Not Tracking Satellites on page 225*
2. *If the receiver is tracking satellites, go to step 7 below.*

Step 7. You May Have a Component that is Malfunctioning

You may have a malfunctioning radio or radio communication cable. If you have another radio to try, swap in the new radio and see if it makes a difference. Otherwise, contact your local dealer or email Thales technical support for assistance.

Your base GPS receiver may be malfunctioning. Follow these steps to determine if the base receiver is the problem:

1. Replace the base GPS receiver with rover GPS receiver.
2. Follow the steps outlined above to set up the rover receiver as an RTK base.
3. If the base radio begins to transmit data, there is a problem with the base GPS receiver. Contact your local dealer or email Thales technical support for assistance.

Rover Radio is Not Receiving Data from Base

	RTK Base	RTK Rover	PP Base	PP Rover
Relevant to		●		

The base GPS receiver by default is set to send data to the base radio once every second. The base radio will transmit this data immediately upon receiving it. Therefore, the rover radio should be receiving data from the base once every second. The receive LED on the front panel of the rover radio, or in the case of an internal radio on the front panel of the Z-Max.Net receiver, will blink green each time a packet of good quality data is received. After examining this LED, you determine that the rover system is not receiving data. Follow the outline below to troubleshoot this problem.

Step 1. Is the Rover Radio Powered Up?

When using the communication module with the UHF radio, there is no action required to power up the radio other than to power up the Z-Max.Net receiver. This automatically applies power to the radio. If using the communication module, go to step 2 below.

Step 2. Is the UHF Antenna Module Connected to the Rover Radio?

Although it is possible for the rover radio to receive transmissions from the base radio without an antenna, the range will be very limited. The rover radio antenna must be connected to the rover radio for proper operation.

- *If the antenna is not connected:*
 - Connect the UHF antenna module to the receiver module.
 - Ensure that the connection to the receiver module is secure and the threaded collar that secures the module is snug and not cross-threaded.

- *If the antenna is connected:*
 - Ensure the connection to the communication module radio is secure and the latch is completely closed.
- If the problem is not yet resolved, go to step 3.

Step 3. Is the Rover Radio Set to the Same Frequency as the Base?

The rover radio must be set to the same frequency as the base radio in order for the rover to receive transmissions from the base. Use the field application software running on the handheld computer to determine on which frequency the base and rover radios are set.

- *If the radio is not set at the same frequency as the base:*
 - Use FAST Survey or the front panel display to set the frequency of the rover radio to match the frequency of the base radio.
- *If the radio is set at the same frequency as the base, go to step 4 below.*

Step 4. Is the Line of Sight Between the Base and the Rover Antennas Obstructed?

Although UHF radios are fairly robust, an excessive amount of obstructions can block out the signal.

- *If the line of sight is not obstructed, go to step 5 below.*
- *If the line of sight is obstructed:*
 1. Move to a less obstructed location. In order to test if the system is functioning properly, move to a location that does not have an obstructed view between the base and rover radio antennas.
 2. If this is not possible, move to higher ground or a location where there is less obstruction.
 3. If, after moving, the rover radio begins to receive data from the base, then the previous location is too obstructed from the base. You will need to either raise the base radio antenna higher, or move the base to a location with less obstruction between the base and rover radio antennas.

- If the problem is not yet resolved, go to step 5 below.

Step 5. Are you Within Range Specifications of Your Radio System?

The range within which your radio system will function varies greatly with the conditions under which the system is being used. With clear line of sight between the base and rover radio antennas, and no interference on the frequencies you are working on, a UHF system can function with tens of miles of separation. Unfortunately, these are ideal situations seldom found. In most situations, the range of UHF radio will be limited to under 5 miles.

- If you are not within range specifications:
 - Move within range. Either move closer to the base system, or move the base system closer to you.
- If you are within range specifications:
 - Move closer to the base receiver to test the system. Since radio range is difficult to predict due the varying effects of local conditions, try moving closer to the base in an attempt to resolve the problem.
 - If by moving closer you find that the rover radio begins to receive data, the previous location is out-of-range of the radio system. You will need to elevate the base radio antenna or move the base to a location closer to you to solve the problem.
- If the problem is not yet resolved, go to step 6 below.

Step 6. Is the Radio Being Jammed?

When working with UHF radios, it is possible that the frequency you are using is being shared with other people in your vicinity. Traffic on this frequency can interfere with the rover system's ability to receive data from the base. The effect may be no reception of base data or intermittent reception of data. Both are detrimental to proper operation of the RTK system. Interference can be a problem with UHF radios.

There are two methods to determine if there is traffic on the frequencies you wish to use. The best method is to acquire a handheld scanner and to listen for traffic on the frequency you plan to use. The second method is to observe the receive LED on the rover radios. The base and rover radio will receive any traffic on the frequency they are set to causing the receiver LED to flash. This is best done before setting up the base system to transmit data. Any flashing of the communication LED indicates some traffic on your frequency. If the base is transmitting data, the rover receive LED will flash about once per second if receiving data from the base. If you observe more random flashing of the communication LED, this is an indication of traffic on the frequency other than the base transmissions.

- *If there is no jamming*, go to step 7 below.
- *If there is jamming*:
 1. Lower the sensitivity of the rover radio. FAST Survey lets you change the sensitivity of the rover radio, and you can also lower the sensitivity of the PDL radio via the front panel display.

Lower the sensitivity of the rover to medium or low. If the traffic on your frequency is not strong in power, lowering the sensitivity of the rover radio may cause the radio to ignore the traffic. This will not help if the traffic is caused by a nearby or very high powered radio.

The disadvantage of lowering the sensitivity is a reduction in the range of your radio system. A lower sensitivity at the rover may cause the rover to not hear the base transmissions as the rover moves farther away from the base.

2. Try another frequency. If you are licensed to operate on more than one frequency, move to a different frequency in hopes that the new frequency has less traffic.

If you have a license for only one frequency, you may need to find another frequency in your area that is clear of traffic in order for the system to function reliably and acquire a license for this frequency if possible.

Step 7. You May Have a Malfunctioning Component in your System

Your rover radio or UHF antenna module may be malfunctioning. There is no way to further isolate this problem unless you have spares for these components. Call your local dealer or email Thales technical support for assistance.

Rover is Not Computing a Position

	RTK Base	RTK Rover	PP Base	PP Rover
Relevant to		●		

Once Z-Max.Net is set to function as an RTK rover, it will only compute RTK quality positions. In order to accomplish this, the rover must collect raw satellite data at its position and also receive RTK correction data transmitted by the base system. Without these two components, the rover receiver will not compute a position.

To determine if the rover system is computing a position, you can utilize either the display on the front panel or FAST Survey on the field terminal (Equip tab, 6 Monitor Skyplot function).

Using either the receiver display or FAST Survey, you have determined that the rover system is not computing a position. Follow the steps outlined below to troubleshoot this problem.

Step 1. Is the Radio Receiving Data Transmitted by the Base?

To determine if the rover radio is receiving data from the base, examine the communication LED on the Z-Max.Net front panel. It should blink once green every time it receives data transmitted by the base. The default frequency of data transmission is once per second.

- *If no data is received*, refer to *Base Radio is Not Transmitting Data on page 229* and then come back to this procedure.
- *If data is received*, go to step 2 below.

Step 2. Is the Communication Module Connected to the Receiver Module?

The rover radio in the communication module must send the RTK correction data it receives to the receiver module in order for the rover to compute a position. For this to happen, the communication module, the connection between the communication module and the receiver module must be correct and secure.

- *If the communication module is not connected:*
 - Connect the communication module to the receiver module. To connect the module, insert the small ledge of the module into the rear of the receiver module housing first as shown on *page 19*. This will correctly align the module. Using the ledge like a hinge, swing the module closed until the latch on the communication module clicks into place.
 - Make sure that the module is well seated, and the latch is completely closed.
- *If the communication module is connected:*
 - Ensure that the module is securely connected. Ensure the connections at the communication module and the receiver module are fully seated.
- *If the problem is not yet resolved, go to step 3.*

Step 3. Is the Communication Module Using the Correct Port?

When setting up the rover, one of the parameters is the port through which the receiver module should expect data from the radio. If the parameter setting does not match the port to which the radio is connected, the receiver module will not find the data from the base. When using the communication module, the port is Port D. Use FAST Survey to verify that port D is set to be the radio port.

- *If the communication module is not using the correct port, change the port setting to Port D.*
- *If the communication module is using the correct port, go to step 4 below.*

Step 4. Is the Receiver Tracking satellites?

Use either the front panel of the receiver or FAST Survey running on the field terminal to determine if the rover receiver is tracking satellites.

- *If the receiver is not tracking satellites, refer to Receiver is Not Tracking Satellites on page 225 and then come back to this procedure.*
- *If the receiver is tracking satellites, go to step 5 below.*

Step 5. Are The Base and Rover Tracking at least 4 Common Satellites?

In order for the rover system to compute an RTK position, the base and rover receivers must observe data from at least 4 common healthy satellites simultaneously. Without this common data, the rover cannot compute an RTK position. FAST Survey includes the ability to inform you of which satellites are being tracked by the base and which are being tracked by the rover and whether or not these satellites are healthy. Use this feature to determine if the base and rover are indeed tracking at least 4 common healthy satellites.

- *If the base and rover are not tracking at least 4 common satellites:*
 1. Check satellite availability.
 - Use the Mission Planning utility from GNSS Solutions to check satellite availability for your current location and time.
 - Look for the number of satellites available higher than 15° above the horizon.
 - Ensure at least 4 healthy satellites are available.
 - If not, you will need to perform your survey at another time.
 - Go to step 6 below if the problem is not yet resolved.

- 2. Move the base or rover if sites have satellite obstructions.
 - If your base or rover site has any obstructions 15° above the horizon, the obstructions may be blocking essential satellites. If obstructions exist at the base or the rover, move the system to an open area.
- *If the base and rover are tracking at least 4 common satellites, go to step 6 below.*

Step 6. Your Rover Receiver May Be Malfunctioning

Contact your local dealer or email Thales technical support for assistance.

Rover is Computing Positions with High Uncertainties

	RTK Base	RTK Rover	PP Base	PP Rover
Relevant to		●		

Using FAST Survey, you find that the rover is computing a position but the uncertainties (HRMS, VRMS) assigned to the position are unacceptably high. Follow the steps outlined below to troubleshoot this problem.

Step 1. Is the Receiver Set to Function as an RTK rover?

The rover GPS receiver must be set to function in RTK rover mode in order for it to compute accurate RTK positions. If the rover receiver is not set in RTK rover mode, the receiver will compute autonomous positions which could contain about 10 meters or more of error. This is probably the problem if HRMS and VRMS values are in the 10s of meters. Use FAST Survey to determine if the system is configured as an RTK rover.

- *If the receiver is not set to function as an RTK rover, use FAST Survey to set the receiver to RTK rover mode.*
- *If the receiver is set to function as an RTK rover, go to step 2 below.*

Step 2. Are the Base and Rover Tracking at least 5 common Satellites?

Although the rover is capable of computing a position with only 4 common healthy satellites with the base, the rover will not attempt to fix ambiguities unless 5 common healthy satellites are observed. Fixing ambiguities is a required process for the rover to compute highly precise RTK positions. FAST Survey will inform you if you currently have a fixed ambiguity solution or a float ambiguity solution. Your field application software will also inform you which satellites are being tracked by the base and which are being tracked by the rover and whether or not these satellites are healthy. If you find that your solution will not fix, look to determine if the base and rover are indeed tracking at least 5 common healthy satellites.

- *If the base and rover are not tracking at least 5 satellites:*
 1. Check satellite availability.
 - Use the Mission Planning utility from GNSS Solutions to check satellite availability for your current location and time.
 - Look for the number of satellites higher than 15° above the horizon.
 - Ensure at least 5 healthy satellites are available.
 - If not, you will need to perform your survey at another time.
 - Go to step 3 below if the problem is not yet resolved.
 2. Move the base or rover if sites have satellite obstructions.
 - If your base or rover site has any obstructions higher than 15° above the horizon, the obstructions may be blocking essential satellites. If obstructions exist at the base or rover, move the system to an open area.
- *If the base and rover are tracking at least 5 satellites, go to step 3 below.*

Step 3. Are HDOP & VDOP Values Too High for Precision Requirements?

Dilution of Precision (DOP) values give a quality indication of the satellite geometry at any given time. Satellite geometry is important to the precision of an RTK solution. In fact, the DOP value is used as a multiplier in the computation of position precision. For example, in the computation of horizontal RMS (HRMS), an estimated precision value is multiplied by the HDOP at that given time to produce HRMS. The larger the HDOP value, the larger the HRMS value. The same relationship holds for VDOP and VRMS. Therefore, poor satellite geometry will result in poor solution precision. The smaller the DOP value, the better the geometry and solution precision. FAST Survey can view current DOP values. If your precision estimates (HRMS, VRMS) do not meet expected values, use this feature to examine the current DOP values.

- *If DOP values are too high*, look for a satellite window with more suitable DOP values to perform the survey:
 - Use the Mission Planning utility from GNSS Solutions to examine expected DOP values for periods during which you would like to perform your survey.
 - Avoid surveying during periods where DOP values are above 4.
 - For the highest level of accuracy, limit surveying to periods where DOP values are between 1 and 2.
 - Remember that obstructions to line of sight between the GPS antenna and the satellites will block out satellite signals. Every time a satellite is lost due to obstructions, DOP values will be adversely affected. An obstructed area may not be suitable to meet your precision needs due to the adverse effect on satellite geometry.
- *If DOP values are not too high*, go to step 4 below.

Step 4. Are Precision Requirements Too Stringent for RTK?

If the RTK system is not delivering the precision requirements you need for your specific task, it is possible that your precision requirements are too stringent for the RTK system. Review your system documentation to determine the precision specifications for the RTK system.

- If the precision is not beyond capability go to step 5 below
- If the precision is beyond capability, your precision requirements are not attainable through RTK surveying. You will need to find some other measurement system to perform your survey.

Step 5. Your Rover May Be Malfunctioning

Contact your local dealer or email Thales technical support for assistance.

This concludes the troubleshooting section. If the tips given here did not help you to resolve your problem with your Z-Max System, please call your local dealer or Thales Navigation technical support for assistance.

This concludes the troubleshooting section. If the tips given here did not help you to resolve your problem with your Z-Max.Net system, please call your local dealer or email Thales Technical Support for assistance.

11. Appendices

RTK Parameters

Data Formats

The following data formats can be processed by a Z-Max.Net rover:

- Ashtech (CPD/DSNP LRK) [also named DBEN]: A compressed company-proprietary data format that includes GPS pseudo-range and carrier phase measurements. This is the default data format.
- CMR: Compact Measurement Record or CMR format is a non-proprietary RTK format that uses data compression techniques to reduce the bandwidth required to transmit RTK data from the base to the rover receiver. In other words, the amount of data that must be transmitted on the data link to perform RTK operations is less with CMR than with other formats. There is also an enhanced format called CMR+.
- RTCM - (RTK): RTCM message types 18, 19, 3, 22
- RTCM - (DIFF): RTCM messages types 1, 3, 9
- RTCM - (FKP): RTCM messages types???
- RTCM 3.0: RTCM message types 1004, 1006, 1008, 1013

Positioning Modes

The RTK positioning mode you choose will determine the available frequency of position output, and will also have some effect on the accuracy of the position. The RTK positioning mode is selected in the rover receiver only using FAST Survey software or via the front panel display.

There are two available modes:

- *Fine Positioning*, also called Synchronized RTK (1 Hz and 5 Hz) or matched time tag RTK. Fine Positioning will compute and output one rover position for each epoch of base station data that has been received.
- *Coarse Positioning*, also called Fast RTK or Fast CPD. Coarse Positioning works by using a single epoch of base station data to compute multiple rover RTK positions.

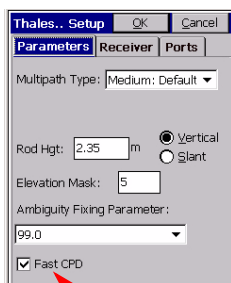

The default is “Coarse Positioning”. In FAST Survey, the check box “Fast CPD” is used to define the RTK positioning mode. It can be found in 3. Configure Rover>Parameters tab. On the front panel, select the POSITIONING function from the SURVEY:RTK ROVER menu (see page 134).

Choosing the right mode for your application is a decision based on a trade-off between frequency of the position output, and the accuracy of the position.

- *Fine Positioning* is generally less consistent in its output but more consistent in its accuracy than Coarse Positioning. Fine Positioning is used when consistent accuracy is more important than the frequency of position output.

In Fine Positioning, the rover receiver will compute and output a single RTK rover position for each DBEN, RTCM, or CMR message it receives from the base receiver. In Fine Positioning, the maximum transmission rate from the base receiver is 1 Hz (once per second). If the H option is enabled the maximum transmission rate can be set to 5 Hz (5 times per second). The maximum position output rate at the remote receiver is equal to the data transmission rate at the base station. In other words, if the base station data is transmitting data at 1 Hz, then the rover can output RTK positions at a maximum rate of 1 Hz.

Fine positioning is less consistent in its output because any interruption in the rover station’s reception of base data will cause the rover to cease outputting positions. An interruption could be caused by a problem at the base receiver or interference in the data link between the base and the rover. Regardless of the cause, the rover will only provide an RTK position when it receives data from the base receiver.

So if base data is blocked for 5 seconds, then the rover will cease to output a position for 5 seconds.

Fine Positioning is generally more accurate because of the issue of latency. Latency is the delay between when raw base data is transmitted from the base, and when the data is used in a rover position computation. Latency degrades position accuracy so the higher the latency, the less accurate the RTK position. With Fine Positioning, the latency of the rover position is very small so the positions are consistently very accurate. The accuracy of Fine Positioning positions is typically $0.5 \text{ cm} + 1 \text{ ppm}$.

- *Coarse Positioning* should be used when consistent and high frequency position updates are required (such as in machine control), and when consistent position accuracy is not the highest priority. The [F] option must be enabled to perform Fast RTK.

In Coarse Positioning mode, the rover receiver can output centimeter level RTK positions at rates up to 10 Hz. Coarse Positioning works by using a single base station message to compute multiple rover RTK positions. In this mode, positions are more independent of the rate at which it receives DBEN, RTCM, or CMR messages from the base receiver. For example, if the base station is transmitting data at 1 Hz (once per second), the rover (in Coarse mode) can output up to ten RTK positions at 0.1-second intervals, using the one base station epoch to compute one matched time-tagged and nine unmatched time-tagged RTK positions.

The inconsistent accuracy is a function of the latency. If the base station is transmitting data at 1 Hz (once per second) intervals and rover is computing RTK positions at 10 Hz (10 times per second), the last RTK position computed before a new base station epoch arrives will have a latency of almost one full second longer than the first position. Therefore, the accuracy of the last position is generally lower than the first position computed after the arrival of base station data. The degradation of accuracy is very slight (if latency is kept to less than 1 second) and is often inconsequential for many applications.

One big advantage of Coarse Positioning is that RTK will continue to be computed even if there is a minor interruption in the base station data. Under good conditions, centimeter-level accuracy can be maintained for data latencies up to 10 seconds. Any degradation in position, either because of latency or cycle slips can be monitored in FAST Survey or by using the RRE serial command (see *Z-Family Technical Reference Manual*). Because Coarse Positioning is running Fine Positioning in the background, any degradation is usually temporary. Cycle slips are typically fixed at the next synchronized epoch.

Logging Modes

The Z-Max.Net system is designed to operate in one of three logging modes:

- Manual
- Auto Point
- Trajectory.

The logging mode is set in the rover receiver using FAST Survey software or the front panel display. Logging mode is referred to as LOG TYPE on the front panel display.

MANUAL. In Manual logging, the user initiates RTK data logging by inputting a site ID and selecting START. The receiver will collect data at that point until the user selects STOP. In FAST Survey, use the 1. Store Points function to perform manual logging.

AUTO POINT. Auto Point logging is ideal when you have a series of closely related sites that you wish to occupy for a certain period of time. In Auto Point logging, the user sets a “Time To Stay” parameter in seconds. RTK data logging is initiated by entering a Site ID. The receiver will collect data at that point for the duration set in the “Time To Stay” parameter. After data collection has stopped, the Site ID will automatically increment by 1, and RTK data logging continues upon confirmation of the Site ID. To automatically increment, the last character of the Site ID must be numeric.

TRAJECTORY. Trajectory logging is ideal for setting stakeouts, or other surveys where data is collected at fixed distance intervals.

In Trajectory logging, the user sets a “Distance Interval” parameter in meters. RTK data logging is initiated by entering a numeric Site ID. As the user traverses across the site, the receiver will monitor the distance covered and collect data at each interval set in the Distance Interval parameter. The Site ID will automatically increment each time RTK data is logged to the receiver. In FAST Survey, use the 6. Auto by Interval function to perform trajectory logging

Position Output Rate

The output rate of RTK positions is controlled by the Recording Interval parameter in the rover receiver. As we discussed in the *Positioning Modes* section, the maximum output frequency is higher when in Coarse Positioning (Fast CPD) mode than with Fine Positioning mode. The maximum output rate is also directly affected by the firmware options that are set:

- If the [F] option is enabled and the receiver is in Coarse Positioning mode, output can be set from 0.1 – 999 seconds.
- If the [H] option is enabled and the receiver is in Fine Positioning mode, then the RTK output can be set from 0.2 – 999 seconds. Remember that in Fine Positioning mode, the output of the rover will equal to the transmission rate of the base receiver. So to output RTK positions at 0.2 seconds, the base must be transmitting at 0.2 seconds.

Base Station Position

Remember that the computation of the rover position is relative to the base position. Since the rover receiver performs the position calculation, it must know the coordinates of the base point to accurately compute the rover position. Any inaccuracy in the base station position is transferred to the computed rover position.

Most frequently, the base station will occupy an accurately known position. That known position is entered into the base receiver. However, it is possible to perform an RTK survey using an unknown point as the base station using approximate coordinates determined by the base receiver.

If you plan to set the base system on an unknown point, there are some disadvantages to this practice that you should be aware of. For every 15 meters of error between the estimated base coordinates and the true WGS84 base coordinates, 1 part-per-million (ppm) of relative error will be introduced into the computed vector between the base and rover system, plus the absolute difference between the computed base station position and the real base station position. For example, assume that the coordinates assigned to the base point are 30 meters off the true base position. This 30-meter offset from truth will produce 2 ppm (0.002 m per 1 kilometer or 0.010 ft per mile) of error in the vector between the base and rover. If the rover is 5 kilometers (3 miles) from the base, this will produce 0.010m (0.030ft) of error in the vector. In most cases, the base receiver will estimate its position to better than 30 meters (probably closer to 10-20 meters), but an error of 50 meters is possible. If you plan to use an estimated position for the base, keep the vector lengths between the base and rover short and ensure the added error is not significant for the survey you are performing.

Antenna Reduction

A concept related to the base station position is antenna reduction.

In RTK, the rover receiver computes the vector from the phase center of the base station antenna to the phase center of the rover station antenna. Usually, the real position of interest is not the phase center of the antenna, but the survey mark (or other landmark) over which the antenna is set up.

To compute the position of the mark instead of the antenna, it is necessary to instruct the receiver to perform an antenna reduction. In an antenna reduction, the antenna heights are included when computing and outputting the rover position.

Antenna reduction is set using FAST Survey or the front panel.

When using RTK and performing an antenna reduction, the antenna height of both the base and the rover must be entered (assuming that they are both over survey marks).

Initialization Process

General Considerations

In RTK real-time surveys, system initialization is achieved when Z-Max.Net has been able to fix an RTK solution for any new position it computes (RTK solution LED then blinks green) and the operator makes sure this operating status is maintained until the end of the survey. In RTK, it is therefore quite naturally that the operator ensures that the initialization process has been successful.

In post-processing surveys, there is the same need for initialization except that the system is not able to inform the operator in real time that this requirement is met. Remember that in this type of survey, the system just has to log raw data.

It is only subsequently, when back at the office to post-process the raw data with GNSS Solutions that the operator will see if the complete set of collected data results in successful and sustained initialization, which is the essential requirement for GNSS Solutions to deliver positions with centimeter-level accuracy.

In static surveys, the risk of unsuccessful initialization is significantly lessened by the fact that the Z-Max.Net GNSS antenna is motionless and the system is operated for relatively long recording sessions with the best possible view of the sky.

This may not be true for kinematic surveys during which the rover is moved from place to place, with real risks of:

- Masking the GNSS antenna causing lock on satellites to be lost
- Stopping recording sessions before enough data has been collected to guarantee initialization.

For this reason, the field operator should be aware of the initialization issue and so take the necessary steps to make sure initialization will not only be achieved but also preserved until the end of the kinematic survey. Initialization may be achieved in three ways:

- On The Fly (OTF)
- By performing a static survey
- On a known point.

On The Fly (OTF)

When using a dual-frequency GPS system such as the Z-Max.Net, there is no requirement that initializations be performed while standing still at one location. It is possible to initialize your kinematic survey while moving about the project site (thus the term “On The Fly”).

Initialization times are about the same as with the static survey method. The advantage of the On The Fly method over the static method is that during the time required to initialize, you can be moving about the project site productively locating points of interest. GNSS Solutions will use this data to initialize and, once initialized, will establish precise positions on the points observed during the initialization time period.

The trick to this method is that you must collect clean data (no loss of lock) during the initialization period, i.e. the first 5-10 minutes of the observation. If loss of lock occurs during the initialization period, you run the risk of not being able to initialize the segment of data between the start and the loss-of-lock times. Any points observed during this time period will have poor precision. For this reason, this method of initialization is best left for project sites where obstructions are a minimum.

Consider a scenario where this method of initialization would be useful:

- You have a landfill that you need to topographically survey. Since the project site is a landfill, most of the area has no obstructions with the possible exception of trees along the perimeter.
- You set up your base station in an open area. You then set up your rover system. You turn on the rover system immediately. As you finish your preparation, the rover system is collecting data for initialization on some arbitrary location.
- After two minutes, you are ready to begin locating topo points. You decide to start at the northeast corner of the landfill because it is wide open with no obstructions. It takes you approximately 1 minute to walk to the location of the first topo shot. By this time, you have already collected 3 minutes of data that will be used towards your initialization.

- You begin collecting topo points. In the next 2 minutes, you have collected 4 topo points without lose-of-lock. By this time, the system has collected 5 minutes of data, enough to initialize. Without hesitation, you continue with your survey.
- When this data is processed, the kinematic survey will initialize using the data collected during the start of the survey. Even points collected prior to initialization will result in precise positions, as long as no loss of lock occurred.
- You successfully continue to collect topo points for approximately 30 minutes without loss of lock. You now are in the perimeter areas where there are trees close to the edge of the landfill.
- While attempting to locate topo points right on the edge of the trees, the kinematic alarm in the receiver sounds indicating that you have lost your initialization. You must now re-initialize.
- It is good practice to establish a re-initialization point near an area where you think you may lose lock. This is done by simply driving a PK into the ground and observing this point prior to entering into the obstructed area. If loss of lock occurs, you can simply observe the re-initialization point for 10 seconds to regain initialization. As an alternative, once you lose lock, you can move out of the obstructed area and collect data on other points where there are no obstructions for approximately 5 minutes, giving the system enough clean data to re-initialize. Then move back into the obstructed area to collect more points.

On-the-fly initialization is an effective method for initializing your kinematic survey since there is no time wasted waiting for the system to initialize. But, you must be careful that you collect clean data during the initialization period or you run the risk of getting poor positions on some of your points.

By performing a static survey

Initialization of your kinematic survey can be accomplished by performing a static survey. Refer to *page 94* for guidelines on static occupation times.

The following scenario is an example of where this type of initialization would be used:

- You arrive on a new project site where you need to perform a kinematic survey. There are no known points in the vicinity so you must perform a static survey in order to initialize your kinematic survey.
- You set up the base station on an existing point with known coordinates or an arbitrary point where approximate coordinates will be assigned.
- You assign a point ID of 0001 to your base point. You drive a PK nail into the ground, approximately 10 feet from the base point, to mark your initialization point. You assign a point ID of 0100 to your initialization point. You set your rover system up over this PK nail, enter the point ID, and observe this point for 5-10 minutes.
- This is sufficient data to statically position this location. You are now initialized. You can pick up your rover system and begin positioning other points.

3. On a known point

Initialization of your kinematic survey can be accomplished by collecting a short amount of data on a point whose position is very well known with reference to the location of the kinematic base station. This is the quickest method for kinematic initialization, requiring approximately 10 seconds of observation time on the known point.

The following scenario is an example where this type of initialization would be used:

- You arrive on a new project site where you need to perform a kinematic survey. You set up the base station on an existing point with known coordinates or an arbitrary point where approximate coordinates will be assigned.

- You assign a point ID of 0001 to your base point. You drive a PK nail into the ground to mark your initialization point. You assign a point ID of 0100 to your initialization point.
- You then initialize your kinematic survey by first performing a static survey on your initialization point. Once initialized, you proceed to position new points using the kinematic mode. You successfully position 10 points when you suddenly lose lock on satellites due to an obstruction (the Z-Max.Net receiver will sound an alarm when fewer than 5 satellites are locked). You must now re-initialize your survey.
- You can re-initialize the survey by returning to your initialization point (0100) and observing it once again, but this time your observation needs to be only 10 seconds in duration because this point is now a known point. Your initialization point is a known point because you successfully performed a static survey on this point earlier.
- When you observe your initialization point the second time, you need to assign it the same point ID as your first observation (0100). By doing so, the post-processing software will know that these are observations on the same point.

Data Recording on SD Card

All data recording in the receiver is done on a removable SD memory card that is installed in the receiver. The amount of data that can be stored depends upon the size of the card. The Z-Max.Net standard memory card size is 64 Mb. Larger cards are optional.

Data recording to the SD memory card is automatic if the card is correctly inserted in the SD card slot, correctly formatted, and the receiver is tracking satellites.

Optionally, the user can change a variety of data collection parameters including the recording interval, the data-recording mode, the site name, the elevation mask, and the minimum number of satellites tracked before recording data.

While data is recording on the SD memory card, the Data Log LED will flash green for each epoch recorded, indicating that the SD memory card is actively in use. If the receiver memory fills up and is not able to log any more data to the SD memory card, the LED will go to constant red.

If the SD memory card is full, you can either delete old files from the card using the SESSIONS menu of the front panel user interface, or else put in a new card.

It is important to power off the receiver using the Power key on the Front Panel before removing the SD card. Also, reformatting the SD card every two weeks during constant use is recommended. See *Initializing the System on page 21* for procedures.

Setting the Data Recording Interval

The default recording interval is 20.0 seconds. The data recording interval can be changed from the front panel LED display (in the SURVCONF submenu) to any value between 0.1 and 999 seconds.

Recording interval can also be controlled from FAST Survey or by applying the RCI serial command to the Z-Max.Net receiver. See *Z-Family Technical Reference Manual*.

Data File Logged on SD Card

During a data recording session, all the data for that session is stored on the SD memory card **as a U-file**.

The U-file is a compressed file that contains the data that is converted to individual files during the download process.

These individual files will include:

- **B** files: Raw data files that store all carrier and code phase data
- **E** files: Ephemeris files that store satellite position and timing information
- **S** files: Site information files that store site occupation information
- **ALM** file: Contains satellite almanac data (used by GNSS Solutions' Mission Planning utility)

The **B**, **E**, **S** and **ALM** files are standard files that are recorded during virtually every session.

In addition, if the Z-Max.Net unit is an RTK rover, the following files will also be created when downloading the U-file:

- **CBEN** file: Contains all RTK solutions
- **OBEN** files: Each of them contains a vector solution.

If the Z-Max.Net unit was collecting attribute or event driven data, the following file will also be created when downloading the U-file:

- **D** file: Event file

The table below provides a summary of the file types, including file names, a description of the information contained in the files, and the file format.

File Type	Description	Format
B file	Raw code and carrier phase data, range data, clock data	Binary
E file	Satellite ephemeris and timing data	Binary
S file	Site information data	ASCII
ALM file	Satellite almanac data	Binary
D file	Event time tags and data	ASCII
CBEN	RTK solutions	ASCII
OBEN	RTK vector solution	Binary

File Naming Convention

The figure below outlines the file naming convention for all created files (except for almanac files):

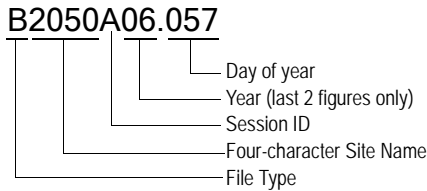

- The first letter is the file type ('U' for U-files, 'B' for B-files, etc.)
- The next four characters indicate the station location or site name. If the user has not entered a site name, then these 4 characters are underscores ("____") unless a previous location name is still in memory. If the site name has been changed during the course of the session, then the last entered site name is used.
- The next character is the session ID. This field automatically increments from A-Z with each new session on a given day. This provides up to 26 unique session IDs for any given day. If more than 26 files are collected in one day, the first digit of the year is used as part of the session ID.

The following file list illustrates the session ID incrementing scheme:

B2050**A**05.257 ... B2050**Z**05.257

B2050**AA**5.257 ... B2050**ZA**5.257

B2050**AB**5.257 ... B2050**ZB**5.257, etc.

- The next two characters indicate the last two digits of the year when the session was terminated (e.g. 06 for year 2006).
- The 3-digit file extension is the day of the year when the session was terminated (e.g. January 1 is day 001; December 31 is day 365).

Almanac file Naming Convention

Almanac files are named:

ALMyy.ddd

Where:

yy is the last two digits of the year

ddd is the day of the year.

Ordering Information

NOTE: Thales Navigation reserves the right to make changes to this list without prior notice.

Item	Designation	Part Number
	GPS Receiver Modules - Post-processing engine - RTK engine	990530-01 990530-03
	GNSS Antenna Module	800961
	Power Module and charger	800974
	USB Cable	110949
	Serial Data Cable	700461
	Communication Modules: - Void Module (V-Module) - GSM only - Thales Radio Only - Thales Radio + GSM - Pacific Crest Radio Only - Pacific Crest Radio + GSM	800964-01 800964-11 800964-03 800964-12 800964-06 800964-15
	UHF Antenna Modules: - UHF Antenna (410-430 MHz) - UHF Antenna (430-450 MHz) - UHF Antenna (450-470 MHz) - Void UHF antenna (pole extension)	800962-10 800962-30 800962-50 800962-01
	Range Pole RF Adapter	800979
	Max RF Adapter	800978
	External Power cable	730477

Item	Designation	Part Number
	Thales U-Link transmitter	110991
	Transmitter Data & Power cable	730476
	PacCrest Transmitter, high power	TN2PDL35W
	PacCrest Transmitter, low power	TN2PDL2W
	GPS-RF Cable	730478
	UHF-RF Cable	730473
	Backpack	204437
	HI measurement tool	701083
	HI measurement plate	204456
	Accessory kit (two cables, a battery and its charger) for CDMA external Raven modem	990572-01
	Hard shell shipping case	800984
	Soft case, blue	205041

Some of the items listed above are also available in bundles. Please contact your dealer for more information.

Port Pinouts

Power Port

The rear panel of the receiver module has one connector for external power. External power is supplied through a 3-pin Fischer connector.

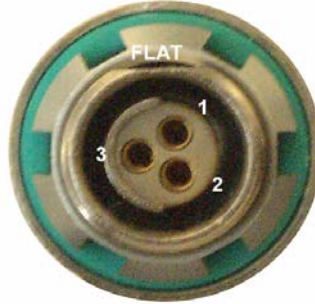

This connector also provides one pin for a boot signal.

Pin	Signal Name	Description
1	GND	External Power Ground
2	VEXT	External Power Input, 10-28V DC
3	Reserved	Leave unconnected

Serial Ports

The rear panel of the receiver module has two external serial connectors – Serial A and Serial B.

Serial A is an RS-232-only port.

Serial B can be configured at the factory to have either RS-232 or RS-422 levels.

Serial A shares the internal logical port A with the USB port. Two devices cannot share this port at the same time.



The pinout descriptions are given in the two tables below. Note that the pinout description for port B will depend on whether it is configured as an RS-232 or RS-422 port.

Serial A

Pin	Signal	Description
1	+12V	+12 V DC regulated voltage (1)
2	GND	Ground
3	CTSA	Serial port A, clear to send
4	RTSA	Serial port A, request to send
5	RXDA	Serial port A, receive data
6	TXDA	Serial port A, transmit data
7	1PPS_OUT	One-pulse-per-second output

Serial B

Pin	Signal	Description
1	+12V	+12 V DC regulated voltage (1)
2	GND	Ground
3	CTSB/RX-	Serial port B, clear to send/RS422 inverting input
4	RTSB/TX+	Serial port B, request to send/RS422 non-inverting output
5	RXDB/RX+	Serial port B, receive data/RS422 non-inverting input
6	TXDB/TX-	Serial port B, transmit data/RS422 inverting output
7	EVENT	Event marker input

(1) The sum of the DC currents taken from the two ports should not exceed 1 A. This output is protected from short-circuits.

USB Port

The high-speed USB port is located in the compartment of the front panel. The connector is a type-B USB connector with the following pin-outs.

Pin	Signal	Description
1	VBus	USB bus power input powers the USB transceiver
2	D-	D- line
3	D+	D+ line
4	GND	Ground
5	GND	Ground
6	GND	Ground

Uploading New Firmware

Occasionally, Thales Navigation will make available new versions of the receiver firmware that contain feature changes and general improvements to the Z-Max receiver. This appendix covers how to upload new firmware to your receiver. Using the following procedures, uploading firmware is an easy and straightforward process.

Step 1 - Acquire the New Firmware

New firmware is acquired in one of two ways:

- The new firmware file can be downloaded to your PC from the Thales FTP site. The firmware file must then be copied from your PC on to an SD card using an SD card reader attached to your PC.
- An SD card containing the new firmware file can be purchased from Thales Technical Support.

Step 2 - Insert the SD Card into the Receiver

With the receiver powered off:

- Insert the SD card containing the new firmware file in to the SD card slot of the receiver module.
- If the SD card slot in the receiver contains an SD card for recording data, remove the data SD card and insert the firmware SD card. Remember to replace the data SD card after firmware uploading is complete.

Note that data SD card and the firmware SD card can be the same card. There is no problem with using the same card for both purposes. To use the same card, copy the firmware file onto the data card using the SD card reader. When the data card is read through the SD card reader, it will contain a file named *Micro-Z.bin*. This is the receiver's file system where data files are stored. This file is required by the receiver to record data. **Do not delete this file.**

Step 3 - Connect Communication and Power Modules

Firmware upgrades also include firmware that operates the Communication and Power Modules. If these modules are part of your system, attach them to the receiver module prior to uploading the firmware to ensure that all modules are at the same level of firmware. To do so:

- Power off the unit then attach the modules to it
- Insert the SD card in the receiver with it still powered off, then proceed to the next step.

If for some reason these modules are unavailable at this time, the new firmware can be loaded to the receiver now and reloaded a second time once the modules become available.

Step 4 - Initiate Firmware Upload

With the receiver powered off, initiate the firmware upgrade process:

- Press the Up key and the power button at the same time. The unit will beep after about 3 seconds.
- Release the key and wait. The receiver will check the SD card to ensure that the firmware file is on the card and that the file is not corrupted. If a good file is found on the SD card, the receiver will start the upgrade.
- Go to Step 5.

If the firmware file is not found on the SD card, the front panel display will show the message “No firmware to upgrade” and all four indicator LEDs will blink red:

- Turn off the receiver to clear this state, and then insert an SD card with valid firmware.

If the firmware file is corrupted, the front panel display will show the message “Bad image checksum, will not upgrade” and all four indicator LEDs will blink red

- Turn off the receiver to clear this state, and then acquire another copy of the firmware from Thales.

Step 5 - Monitor the Upgrade

The firmware upgrade is executed in five stages, and each stage will show a message on the front panel display. As the upgrade proceeds, you should see the following messages:

- “Loading Thales firmware stage #1”
- “Loading Thales firmware stage #2”
- “Loading Thales firmware stage #3”
- “Loading Thales firmware stage #4”
- “Loading Thales firmware stage #5”

If the Power Module is not connected to the receiver module, Step 1 is skipped and the message “No answer from the BATT Module stage #1 skipped” is displayed.

If a Communication Module is not attached, Step 2 is skipped and the message “No answer from comm module stage #2 skipped” is displayed.

The entire upload process should take around five minutes to complete. If all the active modules been upgraded successfully, the system will automatically reboot itself, and will power up in normal operating mode with the new firmware.

If there is a problem with any stage of the upgrade, a warning message will appear on the front panel display in the form "Step X failed" and the 4 LEDs will blink red. Power cycle the system to clear this state and repeat steps 4 and 5. If after one or two attempts this problem continues, contact Thales technical support.

Step 6 - Verify the New Version

Verify that the correct version of firmware was loaded by going to the SYSINFO / VER submenu on the front panel display. If the new version is correct, then the firmware upload is complete. Repeat Steps 2-6 for all other receivers in your possession.

Once all receivers are upgraded, the firmware file can be deleted from the SD card, or else saved as a backup. It is recommended to delete the firmware file from the SD card after the firmware upload, however the receiver will operate properly if the firmware file is left on the SD card.

Firmware Options

Introduction

Receiver firmware options enable different functionality within the receiver. The option must be enabled for that feature to be available. For example, the RTCM Base option must be enabled to set up the receiver as an RTCM differential base station. The table below provides a complete list of the firmware options.

Option Letter	Description
B	RTCM Base
U	RTCM Rover
E	Event Marker
M	GSM Modem
F	Fast Data Output
T	Point Positioning
3	Observables
J	RTK Rover
K	RTK Base
I	Instant RTK
G	Long Range RTK
H	Synchronized 5 Hz RTK

There are two ways to determine what options have been enabled:

1. Using the front panel display. Go to the **OPTIONS** function in the **SYSINFO** menu. The firmware option characters will be displayed in the order presented in the above table. If the character is displayed, then that option is enabled. If the option is disabled, then a dash will occupy the space where that character would be. (*See the Front Panel User Interface section of Chapter 4 - Operation for more information about accessing the front panel display.*)

2. Or a proprietary command sent from a computer via a serial port. Use the \$PASHQ,RID command. The response message to the \$PASHQ,RID command is a string that will look similar to the following:

```
$PASHR,RID,ZA,30,ZM30,BUEMFT3JKIGH0A01*cc
```

To see which options are enabled, look at the string "BUE-MFT3JKIGH" in the response message. Each option is represented by a character displayed in the order presented in the previous table. The description of all options available is given below.

Firmware Options Detailed List

OPTION B - RTCM Base. When this option is enabled, the receiver can be set as an RTCM base station capable of outputting real-time RTCM differential corrections. The output will be in RTCM-104, version 2.3 format. Message types available are types 1, 2, 3, 6, 9 and 16. If the K option (RTK Base) is enabled, RTCM message types 18/19 and 20/21 are also available.

OPTION U - RTCM Rover. When this option is enabled, the receiver can be set as an RTCM rover station capable of receiving real-time RTCM differential corrections. The receiver will decode the RTCM-104, version 2.3 format message types 1, 2, 3, 6, 9 and 16. If the J option (RTK Rover) is enabled, RTCM message types 18/19 and 20/21 can also be decoded.

OPTION E - Event Marker. The E option enables the storage of event time created from a trigger signal. The receiver measures and records event times with high accuracy (down to one microsecond). The receiver stores an event time at the rising edge of the trigger signal (or the falling edge on command) and the time is recorded in the receiver's SD card and/or output through the NMEA-format TTT message.

OPTION M - GSM Modem. The GSM Modem option allows you to set the GSM modem's data link parameters, dial, and display transmit/receive status of the GSM communication link.

OPTION F - Fast Data Output. When this option is enabled, the receiver can be set to output NMEA messages and raw data from the serial port at rates up to 10 Hz (0.1 second intervals). Without this option, frequencies up to 5 Hz (0.2 second intervals) are available.

OPTION T - Point Positioning. When this option is enabled, the receiver can be put into point positioning mode using the \$PASHS,PPO command. Point positioning mode improves the accuracy of an autonomous position of a static point.

OPTION 3 - Observables. This option determines the number of data observables available (see table below).

Option	Code Phase	Carrier Phase
None	C/A on L1, P-Code on L1/L2	None
1	C/A on L1, P-Code on L1/L2	None
2	C/A on L1, P-Code on L1/L2	L1 only
3	C/A on L1, P-Code on L1/L2	L1/L2

OPTION J - RTK Rover. When this option is enabled, the receiver can be set as an RTK (CPD) rover station capable of receiving carrier phase data transmitted by the Base receiver and used to compute real-time centimeter-level RTK positions. This option requires that the Observables option be set to 3. For RTCM message types 18/19 and 20/21, the RTCM Rover option [U] is also required.

OPTION K - RTK Base. When this option is enabled, the receiver can be set as an RTK base station capable of outputting carrier phase data used by the Rover receiver to compute real-time centimeter-level RTK positions. The output will be in proprietary DBEN or RTCM-104, version 2.3 format. This option requires that the Observables option be set to 3. To transmit RTCM 18/19 or 20/21 the B option is also required.

OPTION I - Instant-RTK. The I option is an extension of the J option. When this option and the J option are enabled, the receiver can use the mode Instant RTK which uses a new

data processing strategy for integer ambiguity initialization. The initialization time using Instant RTK typically requires only a single epoch of data to compute a position if there are 6 or more satellites available with reasonably open sky, low multipath, and the baseline length is less than 10 km.

OPTION G - Long Range RTK. The G option is also an extension of the J option. When the G and the J options are enabled, the rover receiver uses the Long Range RTK algorithms incorporating a new data processing strategy for integer ambiguity initialization over long baselines. Using Long Range RTK the rover can typically fix integer ambiguities over baselines up to 50 kilometers in length, when 6 or more satellites are available with reasonably open sky and low multipath.

OPTION H - 5 Hz Synchronized RTK. The H option enables the receiver to output synchronized or matched time-tagged RTK positions at rate of up to 5 Hz (5 positions per second). 5 Hz Synchronized RTK allows the user to attain the better accuracy of matched time-tagged RTK with nearly the same productivity of Fast CPD. This feature is not available when using RTCM format data.

Most Commonly Accessed User Parameters and Their Default Values

The table below lists the more common user parameters. It also indicates where to change the parameter and if applicable, the default value. The Front Panel column indicates the submenu where the parameter can be found.

Description	Front Panel	Default
Antenna offsets	SURVEY:mode	0.0
Base station position	SURVEY:mode	n/a
Baud rate	SETTINGS	9600
Beep setting	SETTINGS	ON
Close session	SESSIONS	n/a
Data recording/ output interval	SURVCONV	20.0
Delete files	SESSIONS	n/a
Elevation mask	SURVCONF	10
Epoch counter	SURVCONF	0
Memory reset	SETTINGS	n/a
Minimum number of satellites for data recording/output	SURVCONF	3
Minimum number of satellites for kinematic surveying	SURVCONF	0
Reset factory defaults	SETTINGS	n/a
Restart session	SESSION	
RTK base port	SURVCONF	
RTK rover port	SURVCONF	
Save user parameters	SETTINGS	n/a
Site ID	SURVEY:mode	
Stop session	SESSION	

Index

A

Access Point Name *57, 60*

Alarm screens *256*

Almanac *92*

Auto connect (Bluetooth) *35*

B

Backpack *23*

backup battery *166*

base port *272*

Baseline *23, 81*

Baseline length *97*

battery life *165*

baud rate *161*

Bluetooth *2, 32*

Bluetooth icon *35*

Bluetooth port *15*

Boundary survey *86*

C

Caster IP address *57*

Cellular modem *23*

cellular modem *3*

centimeter-level accuracy *248*

Charger *19*

Charging the power module *19*

Closed-loop traverse *86, 87*

CMR *247*

Coarse Positioning *246*

Collar (threaded) *20*

Communication LED *15*

Coordinate system *39*

Current

 Constellation *93*

cycle slips *248*

D

Data collection *98*

Data link *23*

Data Log LED *15*

DBEN *247*

Detecting Bluetooth devices *33*

DOP *93*

Downloading field data *110*

E

elevation mask *256*

Entering base position *43*

Entering height *25, 29, 31, 42, 96, 97, 101, 103, 105*

Estimated baseline length *93, 97*

Existing control point *86*

external

 power source *166*

External power *25, 96*

External Power In *16*

F

fast CPD *246*

Fast RTK *246*

FAST Survey *23*

Finding Bluetooth services *34*

Fine Positioning *246*

Fixed-height GPS tripod *10*

Flattened area *20*

Formatting, re-formatting SD card *21*

Front panel display *16*

Front panel interface *96*

G

Geoid model *39*

GNSS antenna module *17*

GNSS Solutions *92*

GNSS Solutions installation CD *7*

GNSS Solutions software *110*

GPRS *23, 57, 60*

GPRS/IP *60*

GPS receiver module *14*

GPS vector *90*

H

Handle *16*

HI measurement plate *25, 95*

I

Initializing *21*

Inserting modules *19*

Intervisible points *86, 88*

IP port number *57, 60*

J

Job *39*

L

last RTK position *247*

Latch *20*

latency *248*

Line-of-sight *89*

Link (direct) *88*

Log in for access to NTRIP caster *57*

Log in for GPRS connection *57, 60*

Logging interval *81*

Loop (strong) *88*

M

matched time tag RTK *246*

Max-Trac *2*

Mission Planning *92, 94*

Modem SIM PIN number *57, 60*

Monitor skyplot *47, 62*

multipath rejection *2*

N

Naming conventions (survey raw data files) *258*

NTRIP *49, 57*

O

observables *268*

Observation

Plan *91*

Times *92, 93*

Observation Range *93*

Observation time *81*

Ordering information *260*

Other external device *23*

P

Password for access to NTRIP caster *57*

Password for GPRS connection *57, 60*

PDOP *93*

PIN number *32, 33*

Pivot point *91*

Points in loop *88*

Poor (availability) *93*

Port A *16*

Port B *16*

Post-processing field data *112*

Power key *16*

ProMark3 CD (user documentation & MobileMapper Office software) *7*

Q

Quality (results) *92*

R

Range Pole *10*

Range-Pole *23*

RRE serial command *248*

RTCM *247*

RTCM2.3 *49*

RTCM-DIFF *49*

RTK Solution LED *15*

S

Satellite

Availability *92, 93*

Distribution *92*

Geometry *93*

Satellite/Power LED *15*

save user parameters *272*

Saving Bluetooth connections for FAST

Survey *36*

Saving Bluetooth settings *35*

SD Card *20*

SD card reader *16*

Site ID *97, 106*

site ID *162, 248*

Specifications *11*

Stake out *66*

Static *96*

Status LEDs *15*

stop session *272*

synchronized RTK *248*

T

Tap and hold *32*

time-tagged RTK *247*

Toggling from base to rover *37*

Total station *86, 87*

Traverse legs *88*

Traverse plan *87*

Tribrach *9*

Tripod *9*

Turning On/Off *21*

U

UHF radio *23*

Units *39*

USB *2*

USB port *16*

V

Vertical control points *87*

Virtual (ports) *34*

V-module *14*

REFERENCE MANUAL

Thales

Survey Solutions Contact Information

In USA +1 408 615 3970 • Fax +1 408 615 5200

Toll Free (Sales in USA/Canada) 1 800 922 2401

In South America +56 2 273 32 14 • Fax +56 2 273 31 87

Email surveysales@thalesnavigation.com

In Singapore +65 6235 3678 • Fax +65 6235 4869

In China +86 10 6566 9866 • Fax +86 10 6566 0246

Email surveysalesapac@thalesnavigation.com

In France +33 2 28 09 38 00 • Fax +33 2 28 09 39 39

In Germany +49 81 6564 7930 • Fax +49 81 6564 7950

In Russia +7 095 956 5400 • Fax +7 095 956 5360

In the Netherlands +31 78 61 57 988 • Fax +31 78 61 52 027

Email surveysalesemea@thalesnavigation.com

Web site www.thalesgroup.com/navigation

THALES