

LINERTEC



Basic Instruction Manual

Total Station LGP-300 series

LGP-302N / LGP-305N

TI Asahi Co., Ltd.

 **Geodesical**

CONTENT

***PRECAUTIONS REGARDING SAFETY* 5**

***1. Functions* 1**

1.1 Names of the parts..... 1

1.2 Keyboard..... 3

 1.3.1 INST Setting..... 6

 1.3.2 About..... 6

 1.3.3 FieldGenius 7

 1.3.4 Quick Setting Menu 8

1.4 Shortcut key..... 8

1.5 Touch screen calibration 9

1.6 Battery..... 10

 1.6.1 Battery Power indicator..... 10

 1.6.2 Removing and attaching the Battery 11

 1.6.3 How to charge the Battery..... 12

1.7 USB connection..... 14

***2. Preparation before Measurement* 15**

2.1 Setting up the instrument..... 15

2.2 Levelling-Up 16

2.3 Centering..... 19

***3 Instrument settings* 20**

3.1 INST Setup 20

 3.1.1 Setting the measure condition 21

 3.1.2 Setting the units..... 21

 3.1.3 Setting parameters of communication ports 22

 3.1.4 Instrument parameters review 22

3.2 Illumination settings..... 23

4.3 About 24

***4. Check and Adjustment* 25**

4.1 The Instrument Constant	25
4.2 Plate Level and Circular Level.....	27
4.2.1 Plate Level.....	27
4.2.2 Circular Level.....	28
4.3 The Optical Sight.....	28
4.4 Laser Plummet	29
5.1 Vertical Cross-hair on Telescope.....	30
5.2 Horizontal Collimation Error C.....	32
5.3 Vertical Index Error.....	34
5.4 EDM Optical Axis and the Telescope Sighting Axis Error	36
6. Specifications	38
7. Standard components	40
Appendix I: Atmospheric correction formula and chart (Just for reference)....	41
Appendix II: Correction for refraction and earth curvature.....	43
8. Labeling.....	45



Before using this product, be sure that you have thoroughly read and understood this instruction manual to ensure proper operation.

After reading this manual, be sure to keep in a convenient place for easy

This Basic Instruction Manual contains the basic operation procedures and precautions on LGP-300N series hardware.

LGP-300N series is an open platform product and you can enjoy variety of application software on it.

Regarding the operations of application software, please refer to their respective manuals.



Copyright © 2014 TI Asahi Co., Ltd.

TI Asahi Co., Ltd. makes no warranty, expressed or implied, including but not limited to any implied warranties or merchantability or fitness for a particular purpose, regarding these materials and makes such materials available.

PRECAUTIONS REGARDING SAFETY

Safety Precautions (Must be followed)

The following items are intended to prevent possible injury to the user or other people and/or damage to the instrument before it occurs. These safety precautions are important to the safe operation of this product and should be observed at all times.

Distinctive Displays

The following displays are used to distinguish precautions by the degree of injury or damage that may result if the precaution is ignored.



WARNING

WARNING

Items indicated by this display are precautions which if ignored would result in serious injury.



CAUTION

CAUTION

Items indicated by this display are precautions which if ignored may result in injury or material.

- Here “injury” refers to injuries such as cuts, burns or electric shock the treatment of which will not likely require hospitalization or long-term attention.
- “Material damage” refers to damage to facilities, buildings, acquired data, etc.

Before using this product, be sure that you have thoroughly read and understood this instruction manual to ensure proper operation. After reading this manual, be sure to keep it in a convenient place for easy reference.

This instrument complies with the protection requirement for residential and commercial areas. If this instrument is used close to Industrial areas or transmitters, the equipment can be influenced by electromagnetic fields.



WARNING



Do not stare into the laser beam directly as this may result in damage to your eyes.

LGP-300N series is a Class IIIa (3R) laser product.



Do not look into the laser radiation aperture directly as this may result in damage to your eyes.



Never use the telescope to view intense light such as direct sunlight or sunlight reflected through a prism as this may result in loss of sight.



Do not disassemble, modify or repair this product as there a risk of laser radiation.



Do not aim the laser beam at a person as it is harmful to the eyes and body. Receive the examination treatment by the doctor when the eyesight or body trouble is doubted by any chance.

- **Electro-Magnetic Compatibility (EMC):**

This instrument complies with the protection requirement for residential and commercial areas. If this instrument is used close to industrial areas or transmitters, the equipment can be influenced by electromagnetic fields.

- Do not use this product in a coal mine, in a location where there is coal dust, or near flammable material as there is a risk of explosion.
- Do not disassemble, modify or repair this product as there is a risk of fire, electric shock and burn injury. If you think the product requires repair, contact the retail outlet where you purchased it or an authorized repair site.
- Only use the BC05 battery charger intended for this product as the battery charger. Use of another battery charger entails a risk of fire or burn injury from the battery bursting into flames due to possible differences in voltage or polarity.
- Do not use a damaged electric cord plug or loose electric outlet when charging as there is a risk of fire or electric shock.
- Do not charge the battery while covered by clothes or similar item as there is a risk of fire if the clothes ignite.

- Do not use the battery or charger when wet as there is a risk of fire and burn injury due to short-circuit.
- To prevent making short-circuit when removing the battery and charger from the case and storing them, apply electrically resistant tape to the poles of the battery. Storing the battery and charger as-is may result in fire or burn injury due to short-circuit.
- Do not throw the battery into fire or expose it to heat as there is a risk of injury if it explodes





CAUTION



For safety, please do the opening inspection and inspection every a fixed period and adjustment.



When the laser beam enters eyes, an unexpected accident might be caused by the blink of eyes. Establish the laser product to avoid the height of eyes of a driving person and walker.



Establish an instrument so that laser beam does not hit a reflection thing as a mirror and a glass window. The reflection beam of the laser is also harmful to the human body.



Besides the time when you measure the distance, cut off the power supply or shade the beam of aperture with caps.



Keep the laser product in the place where the person who does not have the product knowledge such as children does not touch by mistake.



Destroy the power supply mechanism of the instrument so as not to emit the laser beam at the time of disposal.

- Do not remove the handgrip without good reason. If it does come off, be sure to attach it securely to the instrument with screws. If it is not fastened securely, the instrument may fall when you grasp the handgrip, leading to possible injury.
- Do not short the poles of the battery or charger as there is a risk of injury or fire.
- Do not touch any fluid which may leak from the battery as there is a risk of chemical burn injury or reaction.

- Do not insert or remove the electric plug with wet hands as there is a risk of electric shock.
- Do not use the case to stand on as it is slippery and unstable and may cause you to fall, resulting in possible injury.
- Be sure the tripod itself and the instrument on the tripod are both installed securely as insecure installation may cause the tripod to fall over or the instrument to drop, resulting in possible injury.

- Do not carry the tripod with the metal shoe pointing toward another person as the person may be injured if they strike him or her
- The instrument contains a rechargeable battery and it is rechargeable.
- At the end of its useful life, it may be illegal to dispose of the battery.
- Check with your local solid waste officials for details for recycling.



[Usage precautions]

Surveying instruments are high-precision instruments. In order to assure that the Electronic Total Station LGP-300N series product which you have purchased will provide long-lasting maximum performance, the precautions in this manual must be followed. Be sure to follow these instructions and use this product properly at all times.

[Solar observation]



WARNING

WARNING

Never view the sun directly using the telescope as this may result in loss of sight. Never point the objective lens directly at the sun as this may damage internal components. When using the instrument for solar observation, be sure to attach the special solar filter designed for this product to the objective lens.



[Laser beam]

Do not stare into laser beam. LGP-300N series is a Class IIIa (3R) laser product.

[EDM axis]

The LGP-300N series EDM is the red visible laser beam and the beam diameter is very small. The beam is emitted from the objective center and the base plate center hole. The EDM axis is designed to coincide with the telescope sight axis but both axes may not sometimes coincide slightly according to the intense temperature change and time lapse.

[Target constant]

Confirm the Target Constant of the instrument before measurement.

If a different constant is to be used, use the correct constant of the target. The constant is stored in the instrument's memory when turned off.

[Reflectorless and reflector sheet]

- Reflectorless:

The measurement range and accuracy of Reflectorless are based on the condition that laser beam is emitted perpendicular to the white side of the Kodak Gray Card.

The measurement range may be influenced by the shape of the target and its environment. There is a possibility that the range may vary when the target does not satisfy the conditions above at survey work.

- Pay attention to following in case of distance measurement by Reflectorless.

In a situation resulting in low accuracy, perform the distance measurement by Reflector sheet or Prism.

- There is a possibility that correct distance measurement may be impossible by dispersion or reduction of laser beam when the laser beam comes into the target from diagonal angle.

- There is a possibility that the instrument cannot calculate correctly when receiving reflected

laser beam from forth and back directions in case of measuring the target on the road.

- There is a possibility that synthesized values are calculated and the distance may become longer or shorter than the actual one when the operator measure the target of slope or sphere or rugged shape.

- There is a possibility that the instrument cannot calculate correctly by collecting the reflected laser beam from a man or a car that comes and goes in front of the target.

- When using Reflector sheet, set the Reflector sheet to have its surface be approx. vertical to the aiming line. If it is positioned not to be approx. right angle, there is a possibility that correct distance measurement may be impossible by dispersion or reduction of laser beam.

In the following environments, the distance might not be able to be measured.

There is a reflection things (mirror, stainless board and white wall etc.) in the direction of the target and under too strong sun light.

[Battery & charger]

- Never use any battery charger other than the BC05 battery charger as this may result in damage to the instrument.
- If water should happen to splash on the instrument or the battery, wipe it off immediately and allow it to dry in a dry location. Do not put the instrument in the case until it is completely dry as this may result in damage to the instrument.
- Turn off the power when removing the battery from the instrument as removing the battery while the power is still on may result in damage to the instrument.
- The battery mark displayed on the instrument is only an estimate of remaining battery power and is not completely accurate. Replace the battery quickly when it is about to run down as the time a battery lasts on one charge differs depending on conditions of ambient temperature, and the measurement mode of the instrument.
- Confirm the battery level remaining before operating.
- When the remaining battery power becomes low, a message to alert battery run-out starts coming up. When the message appears, replace the battery to a fully charged one immediately. Running out of battery in middle of use may result in loss of data.

[LD POINT, laser pointer]

When you make a correct direction using the “LD POINT”, aim the laser beam at the wall and mark the center and then confirm the discrepancy between the reticle center and the marked point beforehand.

[Interface]

Do not insert or remove USB Connector outdoors.

Be careful not to let dust, mud, sand, water, harmful gas or salty steam enter the card slot or USB connector port.

Be sure to turn the instrument’s power off before inserting or removing the USB Connector.

[Touch panel]

Use the Stylus pen when you touch the panel for operation of software.

Do not touch the panel with any things such as fingertips or pen point as this may scratch and damage the screen.



[Storage and operating environment]

- To prevent making short-circuit when removing the battery and charger from the case and storing them, apply electrically resistant tape to the poles of the battery. Storing the battery and charger as is may result in fire or burn injury due to short-circuit.
- Avoid storing the instrument in places subject to extreme high, low or radically fluctuating temperature. (Ambient temperature range during use: -20°C to $+50^{\circ}\text{C}$)
- Distance measurements may take longer when atmospheric conditions are poor such as when heat shimmer is present. When storing the instrument, always put it in its case and avoid storage in dusty location or location subject to vibration or extreme heat or humidity.
- Whenever there is a sharp temperature difference between the instrument's storage and usage locations allow the instrument to adjust to the ambient for an hour or more before use. Be sure to protect the instrument from the sun if the location is subject to intense direct sunlight.
- During surveys for which the survey precision or atmospheric measurement method has been defined measure the atmospheric temperature and pressure separately and enter those values rather than using the Automatic Atmospheric Correction function.
- The battery should be charged approximately once per month if the instrument is to be stored for an extended period of time. The instrument should also be removed from its case occasionally and aired out.
- In addition to these precautions, be sure to handle the instrument properly at all times following the descriptions given in the various sections of this manual to assure safe and proper measurements.

[Transporting and carrying the instrument]

- Be careful to protect this instrument from shock of impact and excessive vibration which may result in damage during transportation and shipment.
- When transporting the instrument, always put it in the case and wrap shock-absorbing materials around it and be sure it is handled as "FRAGILE".

[Checks and repairs]

- Always check the instrument before beginning work and check that the instrument is maintaining the proper level of precision. TI Asahi bears absolutely no responsibility for damages due to survey results obtained from surveys conducted without an initial instrument check.

Never disassemble the instrument, battery or charger even if you do detect an abnormality as there is a risk of fire or electric shock due to short - circuit. If you think the product requires repair, contact the retail outlet where you purchased it or an authorized repair site.

- Never disassemble the instrument, battery or charger even if you do detect an abnormality as there is a risk of fire or electric shock due to short-circuit, If you think the product requires repair, contact the retail outlet where you purchased it or an authorized repair site.



1. Functions

1.1 Names of the parts



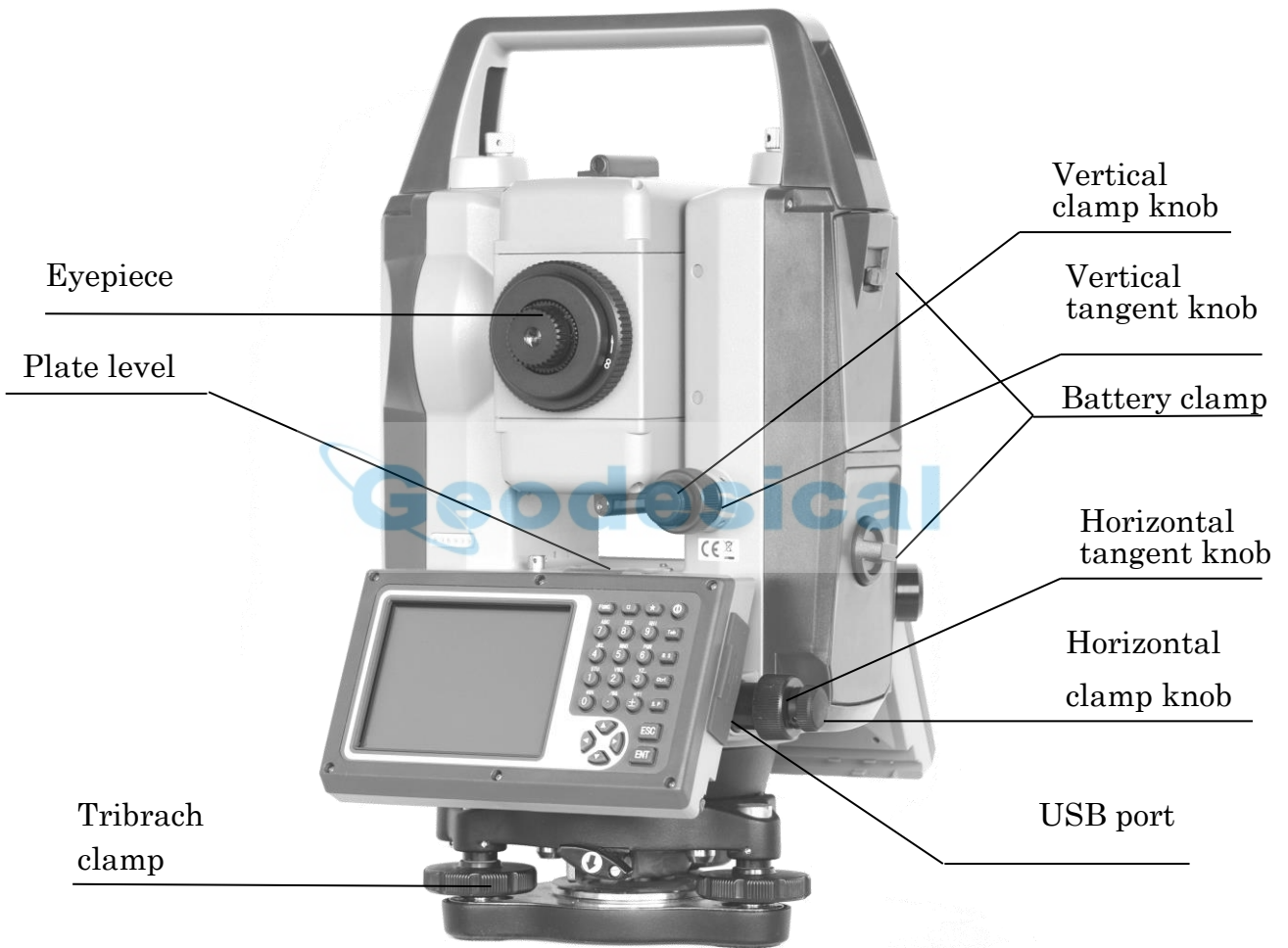

1.2 Keyboard



LGP-300N series is equipped with two color touch screens and alphanumeric keypad, operation by both touching screen and pressing keyboard is possible.

Do not touch the screen with ball-pen, pencil or other sharp thing to avoid damage on instrument.

Keys	Name	Functions
0~9/ A~!	Alphanumeric keypad	Enter text and numerical values.
α	Shift key for character entry	The current entry method can shift among number, smaller letter and capital letter.
★	Star key	Normal configurations can be set here
Tab	Tab key	Move the cursor right or next position
BS	BackSpace key	Move the cursor left and delete one character

Ctrl	Ctrl key	Same with the Ctrl key of PC
Space	Space key	Enter the space
Enter	Enter key	Confirm an entry or selection
ESC	Escape key	Quit a screen or edit mode without saving changes. Return next higher level
FUNC	Function key	Perform variable functions defined by program screen
◀▲▼▶	Navigation key	Control the focus bar within the screen and the entry bar within a field
	Power key	Turn on/off the instrument



Function introduction	Display
<p>After initiating the instrument the screen will go to present “Welcome Interface” which is shown right.</p> <p>Main Menu consists of “FieldGenius”, “INST Setup (Instrument Setup) ” and “About (Relevant Information) ” icons.</p>	 <p>The screenshot shows a dark grey background with four blue icons arranged in a 2x2 grid. Each icon has a white label below it. The icons are: a mountain range (FieldGenius), a surveying level and tripod (Settings), a person silhouette (About), and a door with an arrow pointing out (Exit).</p>

Geodesical

1.3.1 INST Setting

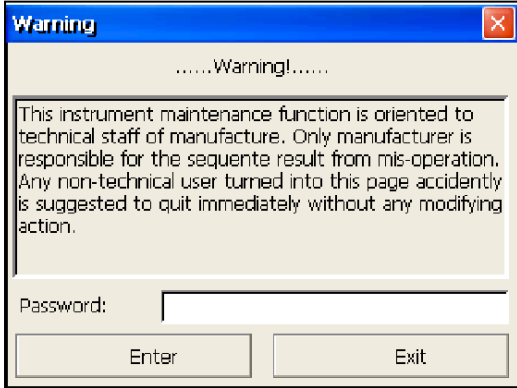
Function introduction	Display
<p>Instrument setup function is mainly applied for instrument settings, instrument calibration and generation and management of instrument constant. It is made up of a series of functions such as “compensator linear correction”, “compensator zero correction”, “horizontal axis error correction”, “index correction”, “instrument settings”, “distance constant settings”, “communication port settings”, “configuration management”, etc.</p>	 <p>The image shows a 'Warning' dialog box with a blue title bar and a red close button. The text inside reads: '.....Warning!.....' followed by a paragraph: 'This instrument maintenance function is oriented to technical staff of manufacture. Only manufacturer is responsible for the sequente result from mis-operation. Any non-technical user turned into this page accidentally is suggested to quit immediately without any modifying action.' Below the text is a 'Password:' label and an empty text input field. At the bottom are two buttons labeled 'Enter' and 'Exit'.</p>



1.3.2 About

Function introduction	Display
<p>The “About” function Offers information of manufacturer and software version.</p>	 <p>The image shows the 'About' screen of the software. It features a dark background with a world map. At the top right is the 'LINERTEC' logo in red. Below it, the text reads 'TI Asahi Co.,Ltd.' and 'www.tilinertec.com'. A prominent orange banner in the center contains the text 'WinCE Total Station'. At the bottom left, the version information is listed: 'B.M V2.2.0.3 131202', 'S.T V2.2.0.3 131202', and 'C.D V2.2.0.3 131202'. A small red arrow icon is located at the bottom right.</p>

1.3.3 FieldGenius

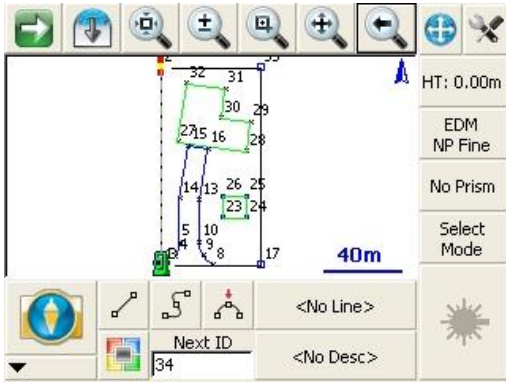
Function introduction	Display
<p>By pressing FieldGenius icon, you can start up professional surveying and cartography program “MICROSURVEY FieldGenius”. For the operation of FieldGenius, visit FieldGenius http://www.microsurvey.com/products/fieldgenius/ website and download its operating manual.</p>	

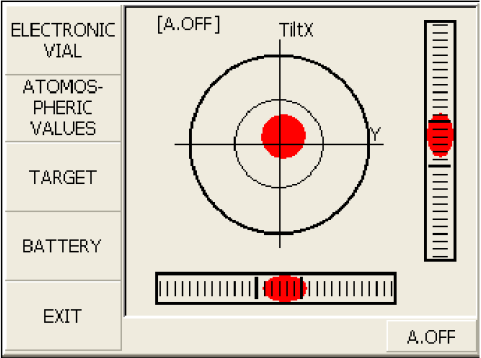

1.3.4 Quick Setting Menu

Function introduction	Display
<p>By pressing 【★】 key, you can quickly enter into Quick Setting Menu. In this function, you can refer to electronic vial and check battery status. Also settings such as atmospheric values and EDM targets can be changed anytime in middle of work.</p>	

1.4 Shortcut key

1) The following is the list of shortcut keys available for LGP-300 Series.

Key combination	Description
	Power on/off
★	Enter into setting mode directly/turn on the electronic bubble
α	Shift among number, smaller letter and capital letter
FUNC+BS	Turn on/off backlight of key panel in face left position
FUNC+TAB	Turn on/off backlight of key panel in face right position
CTRL+ESC	Show Windows start up menu

CTRL+TAB	Start touch screen calibration
FUNC+CTRL	Turn on/off soft keyboards
FUNC+←	Turn on/off LCD display in face left position
FUNC+→	Turn on/off LCD display in face right position

2) How to change character input method of Alpha-numeric keys

By pressing **Q** key, character input method of Alphanumeric keys will be changed. The inputting method will be display on the lower right corner.



1.5 Touch screen calibration

When you operate on the screen, if your device isn't responding to you taps, you may need to recalibrate your screen. In any picture, press the combination key "CTRL+TAB" so as to enter into touch screen calibration. The calibration process is shown in the figure below.

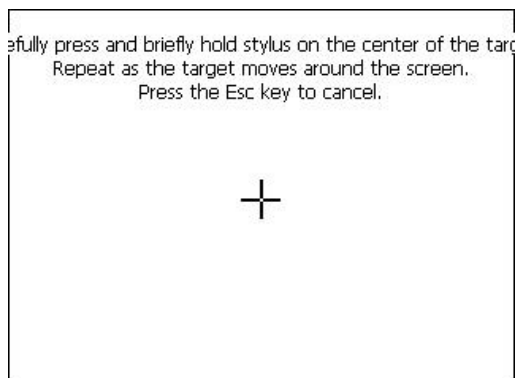

- 1) Carefully press and briefly hold stylus on the center of the target. Repeat as the target moves around the screen.

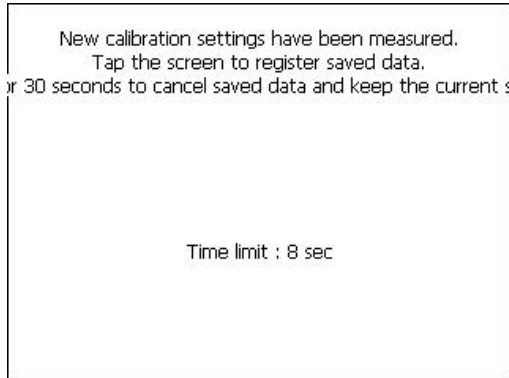

2) After all the targets are clicked, the screen will display as left, tap the screen to register saved data. The screen goes back to Stylus Properties menu.

1.6 Battery

1.6.1 Battery Power indicator

At any screen, press **【★】** key to open the Quick Setting Menu.

Select Battery, battery level will be seen following **Battery Level**.

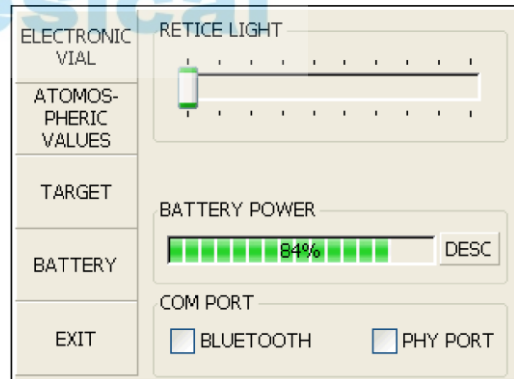

NOTE:

1. The battery's working time will be affected by many factors, such as ambient temperature, recharging time, recharging and discharging times. So we suggest the users recharge the battery full or prepare several full batteries before operation.

2. The battery symbol only indicates power capability for current measurement mode. The power consumption in distance measurement mode is more than in angle mode, if the instrument enters into distance measurement mode from angle mode, the power maybe auto-off because of lower battery.

3. The symbol only indicates the supply power but not the instantaneous power change. And if the measurement mode changes, the symbol will not show the power's decrease or increase immediately.

4. It is suggested that user should check every battery power before field work.

1.6.2 Removing and attaching the Battery

[Removing the Battery]

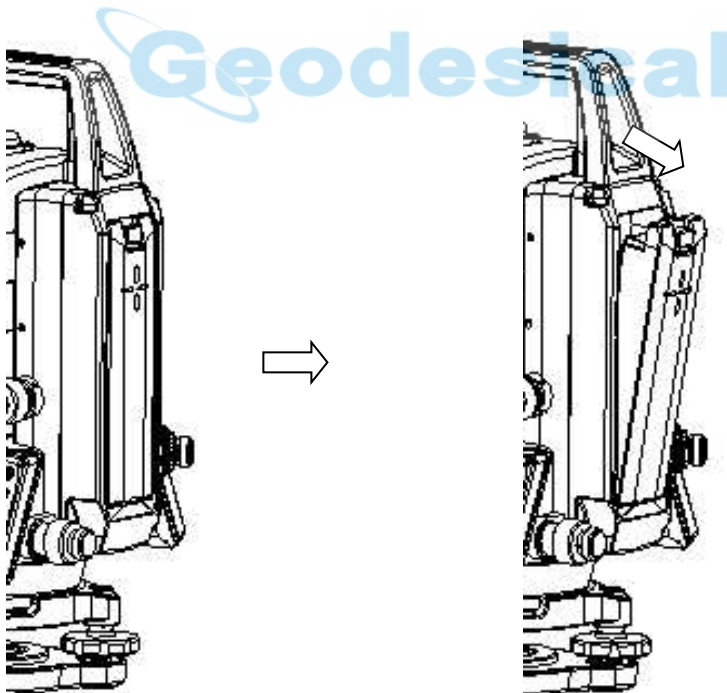

- ① Push upper part of the battery.
- ② Lift up the battery pack and remove it from the instrument.

[Attaching the Battery]

- ① Place the electric contact on the bottom of the battery pack onto the protrusion of the instrument and push the battery pack down into place.
-

1.6.3 How to charge the Battery

The LGP-300 comes with two lithium-ion rechargeable batteries with a typical operating time between 8(EDM+ETH) to 22hours(ETH only).

Specifications



Battery Type: Li-ion
Voltage: 7.4VDC
Capacity: 4400mAh

[Battery Charger]

AC Adapter

Input: 100-240VAC ~50/60Hz 0.58A
Output: 12.0VDC 2.0A

[Charging the battery]

Battery Charging Description

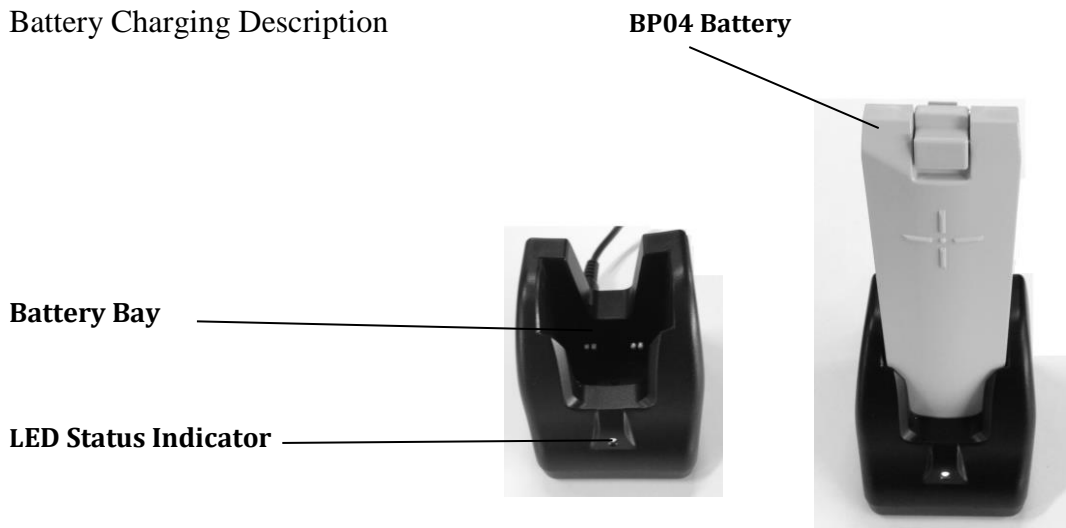

Plug the AC cord to AC Adapter
 Plug in AC Adapter to Battery Charger
 Plug the AC wall battery charger into the wall socket and LED turns green
 Place your battery in charger bay correctly and make sure LED turns red
 Wait until battery LED indicator turns GREEN for a full charge.

LED	Description
NONE	AC cord or AC adapter is not correctly connected
RED	Battery is being re-charged
GREEN	Battery charge is finished.

!	<i>A fully discharged battery will take approximately 2.5 hours to fully charge.</i>
!	<i>Contact a Recycling Center to ensure proper disposal of lithium-ion Batteries.</i>

1.7 USB connection



- The file in the instrument could be read through ActiveSync software by USB cable.
 - External memory stick could be used by USB Host connector. The file in the external memory stick could be read in the instrument interface.
- 1) Open the cover of USB which behind the display panel ;
 - 2) Input external memory stick into USB Host connector ;
 - 3) The external memory stick could be recognized as hard disk automatically. It could be file copy etc.

2. Preparation before Measurement

2.1 Setting up the instrument

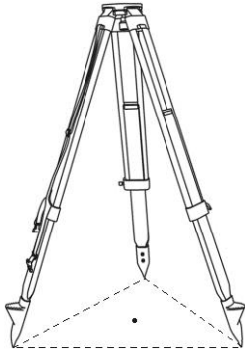

(1) Set up the tripod first: extend the extension legs to suitable lengths and tighten the screws on the legs. Make sure the legs are spaced at equal intervals and the head is approximately level. Set the tripod so that the head is positioned over the surveying point. Make sure the tripod shoes are firmly fixed in the ground.

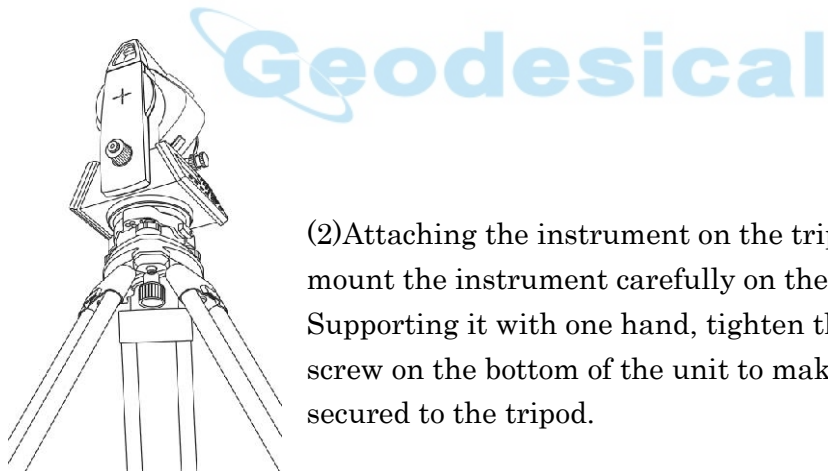

(2) Attaching the instrument on the tripod head: mount the instrument carefully on the tripod head. Supporting it with one hand, tighten the centering screw on the bottom of the unit to make sure it is secured to the tripod.

2.2 Levelling-Up

(1) Basic Levelling-Up with the circular level

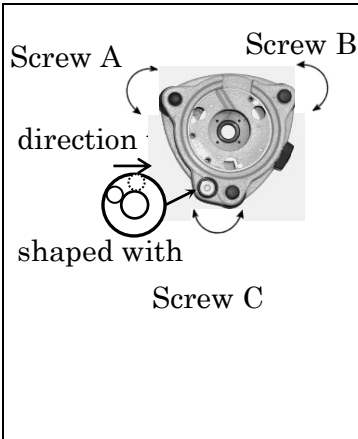
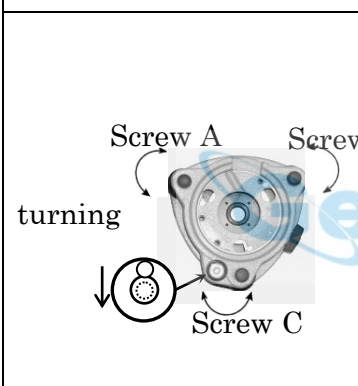
 <p>Screw A Screw B</p> <p>direction</p> <p>shaped with</p> <p>Screw C</p>	<p>1. Move the foot screws A and B in opposite directions so that the circular bubble is perpendicular to a line shaped with screw A and B. The direction of rotation in left thumb indicates the movement of the circular bubble.</p>
 <p>Screw A Screw B</p> <p>turning</p> <p>Screw C</p>	<p>2. Move the bubble to the center of the circle by turning screw C.</p>

(2) Accurate Levelling-Up with plate level

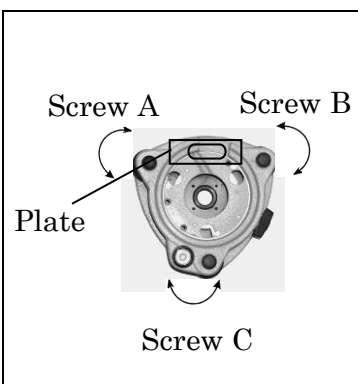
 <p>Screw A Screw B</p> <p>Plate</p> <p>Screw C</p>	<p>1. Loosen the horizontal motion clamp, and turn the instrument till the plate level is parallel to a line shaped with screws A and B. Adjust the screws A and B to make the bubble in the center of the level.</p>
---	---

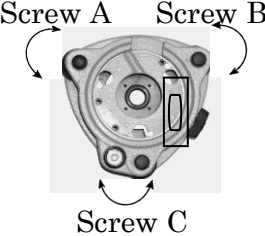

2. Loosen the horizontal motion clamp, and turn the instrument approximately 90°. Adjust the screw C until the bubble in the center of the level.

3. Repeat above steps until the bubble remains in the center of the plate level while the instrument is rotated to any position.

(3) Accurate Levelling-Up with Electronic Level on the screen

It is convenient for LGP-300N series to level-up with electronic level,

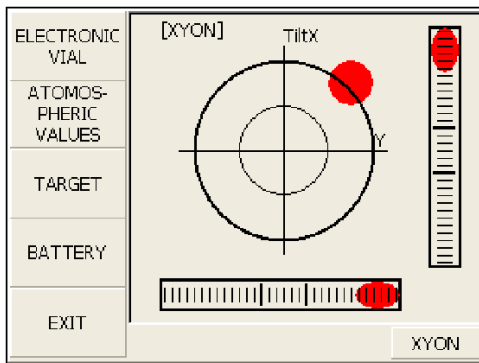

especially when it is difficult to observe the circular level and plate level.

Firstly, press the key **【★】** to turn on the electronic bubble as shown in left figure. On the electronic bubble screen, five function keys are displayed in the left column, which are listed as follows:

【TiltXY】 dynamic display of electronic bubble

【T.P】 observation and setting of temperature and atmospheric pressure

【Target】 target condition of surveying

【Battery】 dynamic display of battery level

[Exit] exit the electronic bubble screen

Secondly, level it by turning three foot screws and ensure the bubble is in the plate level. Make sure the red spot is in the center.

Note:

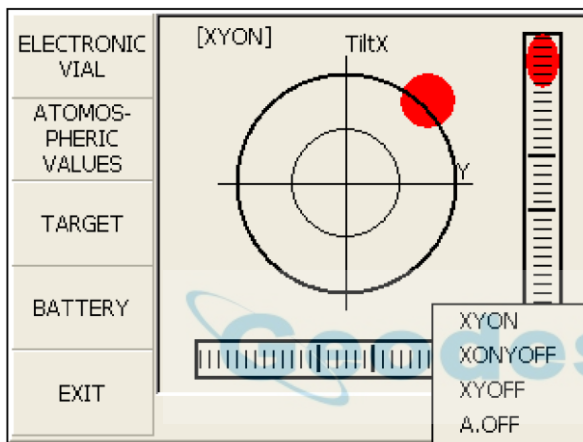

As shown in the right figure, you can realize transformation of compensation options by pressing the lower right button.

[XYON] compensate horizontal angle and vertical angle at the same time

[XONYOFF] just

compensate X axis

[XYOFF] don't compensate X axis and Y axis

[A.OFF] don't compensate X axis and Y axis, and turn off the popup function of electronic bubble.

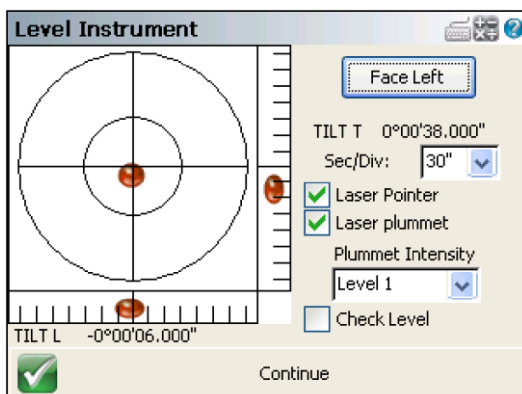

In FieldGenius software, the Level display is always shown as left figure.

2.3 Centering

Centering with Laser Plummet

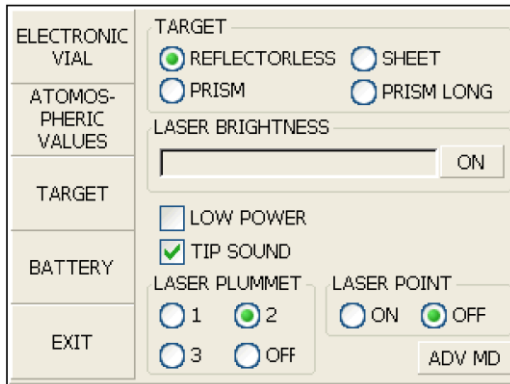

Press the key **【★】** to enter into the display as shown in the left figure.

Operation Steps:

- ① Click the “target” button and you can turn on laser plummet and set it as three levels of brightness. Thus, that laser emits downwards

can be seen.

- ② Loosen the center screw of tripod, and move the base plate on tripod head until the laser spot coincides with ground mark point. Then tighten the center screw.
- ③ Repeat leveling and two steps until the instrument keeps leveling and the laser spot coincides with ground mark point when rotating alidade of instrument in any direction.
- ④ After centering is finished, turn off laser plummet for power saving.

3 Instrument settings

Instrument settings software is applied for settings and calibration of instrument, generation and management of instrument constant. It is made up of a series of functions such as “compensator linear correction”, “compensator zero correction”, “horizontal axis error correction”, “index correction”, “instrument settings”, “distance constant settings”, “communication port settings”, “configuration management”, etc.

3.1 INST Setup

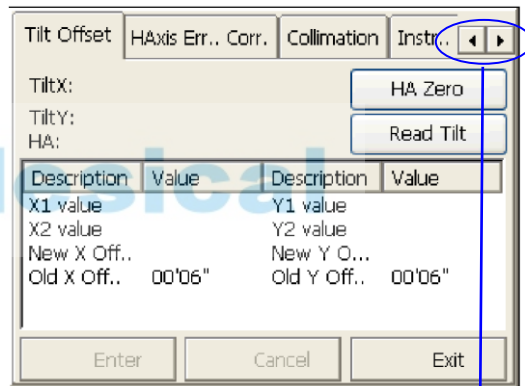
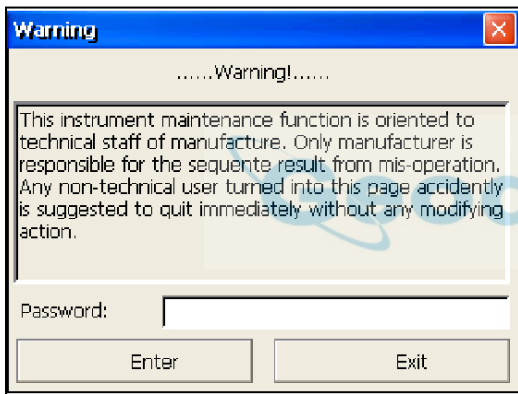

Tap ◀ or ▶ keys to display other settings

Enter “instrument settings” program by clicking “INST Setup” icon on the Main Menu. And then input the password “12345678” to display configuration settings screen. On the screen tap ◀ or ▶ keys, different setting screen can be shifted.

NOTE: This password is open for all users, current configuration settings can be checked here, but not be adjusted. If you want to adjust these settings, please contact local distributor or TI Asahi.

3.1.1 Setting the measure condition

Operation:

1. The distance measurement mode will be: Fine, Coarse, Repeat Fine, Average Fine, Tracking.

Measure Condition	Units Settings	Data Monitor
Dist.. Mode:	Fine	
Tilt Corr...:	NO	
Coll.. Corr...:	Yes	
CR Corr...:	K=0.142	
Sea Level Corr...:	No	
Targ.. Type:	Reflector	

2. Tilt correction mode will be: HV, V, NO, Always off.

3. Collimator correction mode will be: Yes or No.

4. CR correction mode will be: K=0.142, K=0.2, No.

5. Sea Level correction mode will be: Yes or No.

6. Target Type mode will be: Prism, No Prism, Reflector. You could press "Enter" to keep the setting or press cancelled.

3.1.2 Setting the units

Measure Condition	Units Settings	Data Monitor
Angle Unit:	DMS	
Angle Prec...:	1 SECOND	
Distance Unit:	Meter	
Distance Prec...:	0.1mm	
T.Unit:	Centigrade	
ATP.Unit:	HPA	

Operation:

1. Angle unit mode will be: DMS, GON, MIL.

2. Angle Precision mode will be: 1 second, 0.1 second or 0.5 second.

3. Distance Unit mode will be: Meter, US Feet, Feet.

4. Distance precision mode will be: 1mm or 0.1mm.

You could press "Enter" to keep the setting or press cancelled.

3.1.3 Setting parameters of communication ports

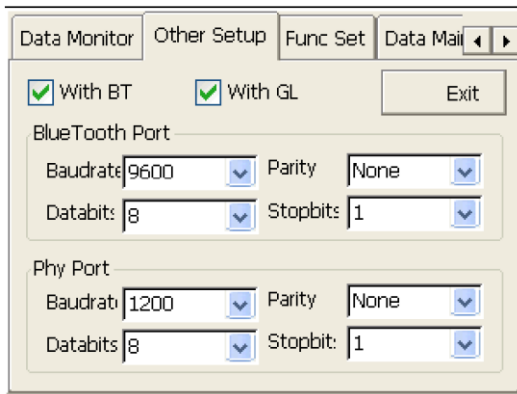

As left figure shows, click “Other Setup”, you can activate bluetooth(BT) and guidelight(GL), and set parameters of “Bluetooth Port” and “Phy Port”.

3.1.4 Instrument parameters review

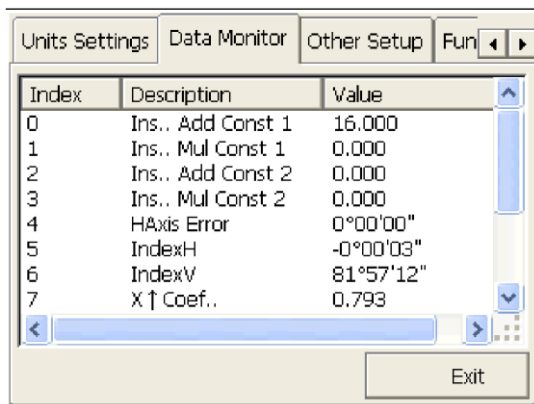

Click “Data Monitor” used for reviewing the setting parameters.

3.2 Illumination settings

ELECTRONIC VIAL	RETICE LIGHT
ATOMOSPHERIC VALUES	
TARGET	BATTERY POWER
BATTERY	DESC
EXIT	COM PORT <input type="checkbox"/> BLUETOOTH <input type="checkbox"/> PHY PORT

Press the **【★】** button and click “Target” and “Battery” keys in order to go on with illumination settings including “Cross Light” and “Laser Point”.

Cross Light: Click this item to turn on the reticle illumination, and move the slipping button to adjust reticle illumination.

ELECTRONIC VIAL	TARGET <input checked="" type="radio"/> REFLECTORLESS <input type="radio"/> SHEET <input type="radio"/> PRISM <input type="radio"/> PRISM LONG
ATOMOSPHERIC VALUES	LASER BRIGHTNESS
TARGET	<input type="checkbox"/> LOW POWER
BATTERY	<input checked="" type="checkbox"/> TIP SOUND
EXIT	LASER PLUMMET LASER POINT <input type="radio"/> 1 <input checked="" type="radio"/> 2 <input type="radio"/> ON <input checked="" type="radio"/> OFF <input type="radio"/> 3 <input type="radio"/> OFF ADV MD

Laser Point: Turn on/off the laser flash before distance measurement.

4.3 About



Instrument firmware version is shown here.

Operation :

1. Click “About” icon on desktop.
2. Press “Exit” to return the basic measurement.

4. Check and Adjustment

4.1 The Instrument Constant

1) Check

It is suggested to observe and compare the instrument with a testing line which is set on stable ground with a particular accuracy, though error is not generally included in the instrument constant. If the testing line is unavailable, you can set it for 20 meters or so by yourselves, then check and compare it with your new instrument.

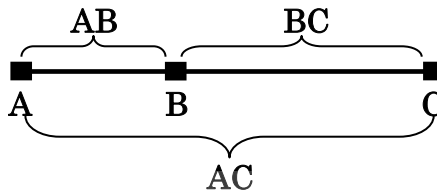

1. Select a point B on the approximately horizontal line AC with about 100 meters long. Measure the distances of lines AB , AC and BC .

2. The instrument constant can be calculated;

$$\text{Instrument constant} = AB + BC - AC$$

3. If there is a difference between the instrument standard constant and the calculated value , colligate the measured constant and the prism constant to get a new value ,then input the value into the instrument as a prism constant .

4. Compare length of the instrument's testing line again with a certain standard testing line.

5. If the difference is over 5 mm after the preceding operations, it is necessary to reset the instrument constant.

2) Adjustment

About instrument constant setting, you must contact LINERTEC distributor to do that.



4.2 Plate Level and Circular Level

4.2.1 Plate Level

1) Check

1. Mount the instrument on a stable device (as tripod, adjusting device), and fix it.
2. Level the instrument until the plate level is parallel to a line linking leveling foot screws A and B, then adjust the two screws to center the air bubble.
3. Turn the instrument 180° , observe the moving direction of the bubble, if it is still centered, no adjustment is necessary, if not, you have to adjust it.

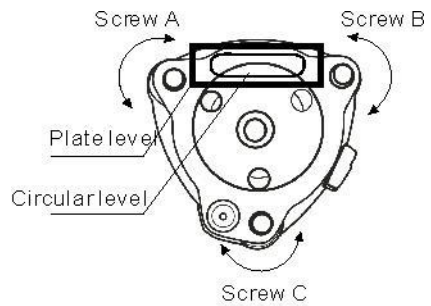

2) Adjustment

1. Mount the instrument on a stable device and fix it.
2. Level it roughly.
3. Turn the instrument and make the plate level be parallel to a line linking two leveling foot screws, then adjust the two screws to center the air bubble.
4. Turn the instrument 180° , adjust the Adj-screw with adjustment pin slightly to correct half of the bubble's displacement when it doesn't move,
5. Repeat the operation (3) and (4) until the air bubble remains centered in any position.

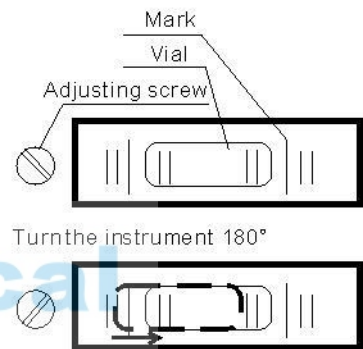

4.2.2 Circular Level

1) Check

1. Mount the instrument on a stable device and fix it.

2. Level it accurately by the plate level.

3. Observe the bubble of the circular level, if it is centered, no adjustment is necessary, if not, you have to adjust it.

2) Adjustment

4. Mount the instrument on a stable device and fix it.

5. Level it accurately by the plate level.

6. Adjust the three adjusting screws to center the bubble by a wrench.

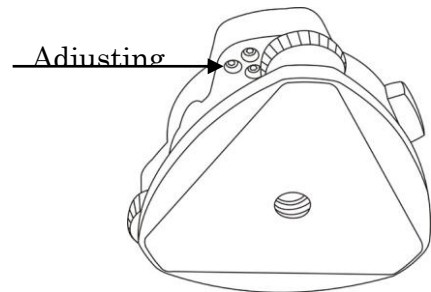
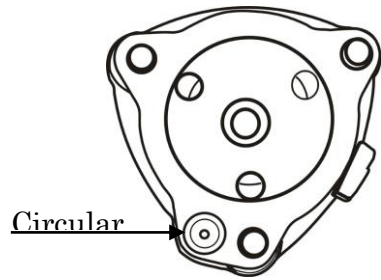

Geodesical

Note: Be careful when adjusting the three screws, and the tightening tension is identical for them.

4.3 The Optical Sight

1) Check

1. Mount the instrument on a tripod and fix it.

2. Set a cross mark target which apart from the instrument about 50m.

3. Take the telescope sight the cross mark.

4. Observe the optical sight collimator

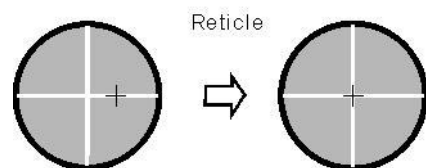
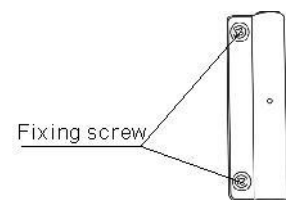

whether collimating the cross mark, if collimate the mark, adjustment is not necessary; if not, adjust it.

2) Adjustment

1. Mount the instrument at the tripod and fix it.
2. Set a cross mark target which apart from the instrument about 50m.
3. Take the telescope sight the cross mark.
4. Loosen two fixing screws, adjust the collimator, then fix the two screws again.

4.4 Laser Plummet

1) Check

1. Set the instrument on the tripod, and place a piece of white paper with a cross drawn on it right under the instrument.
2. Move the paper so that the intersecting point of the cross comes to the centre of the laser mark.
3. Rotate the instrument around the vertical axis, and observe the centre mark position against the intersecting point of the cross at each 90° rotation.
4. If the laser mark always coincides with the intersecting point, no adjustment is necessary.

Geodesical

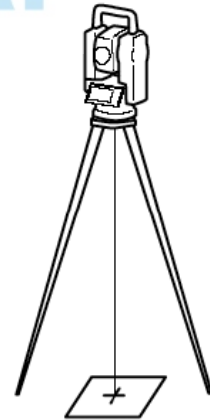

2) Adjustment

When a center part where a cross intersection and the laser mark look the brightest shifts by 0.5mm or more (at the instrument height 1.5m), it is necessary to adjust it.

A repair engineer does this adjustment. Please contact the LINERTEC dealer.

5.1 Vertical Cross-hair on Telescope

1) Check

- (1) Set the instrument up the tripod and carefully level it.
- (2) Set a point A front the instrument 50m apart;
- (3) Collimate the point A and adjust the vertical tangent screw; If the point appears to move continuously on the hair, adjustment is not required. Otherwise, adjust it.

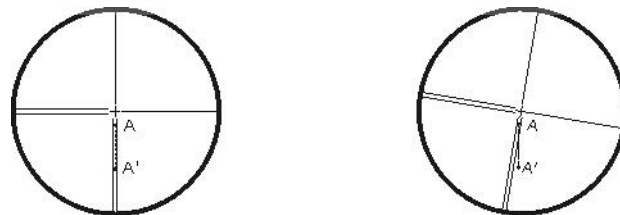

2) Adjustment

- (1) Set the instrument, and set the point A front the instrument 50m apart.
- (2) Take off cover of telescope eyepiece, there are 4 screws for the reticle part.

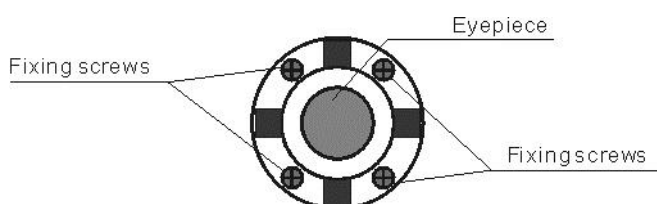

- (3) Loosen all four fixing screws slightly with the cross screw-drive.
- (4) Revolve the eyepiece section so that the vertical cross-hair coincides to point A, finally, re-tighten the four screws.
- (5) Repeat the checking and adjusting until there is no deviation.

NOTE:

1) After the adjustment of cross-hair, please check the collimation error and vertical index error.



2) Refer to the chapter “5.9 EDM Optical Axis and the Telescope Sighting Axis Error” to check the axis. At last check the collimator error again.

5.2 Horizontal Collimation Error C

If the telescope's sight line isn't perpendicular to the horizontal axis, the collimation error will appear. The assembling, transportation and operation will cause this error.

If the collimation error isn't over the permitted range, with the program the instrument can correct this collimation error.

NOTE: After the program correction this deviation error is also on the instrument.

1) Check

(1) Set-up the instrument on tripod or adjustment platform and leveling accurately.

(2) Aim at the cross-hairs of collimator or the obvious target at a distance. Get the face left angle reading H1 and the face right angle reading Hr.

(3) Calculating the horizontal collimation error C according to $C = (H1 - Hr \pm 180^\circ) / 2$, if $C < 8''$, no adjustment will be necessary. If $C > 8''$, proceed with the following adjustment.

2) Adjustment by program:

Set-up the instrument on tripod or adjustment platform, and leveling accurately.

Procedures:

1. Power on and enter into INST Setting. On the screen tap ◀ or ▶ keys until Collimation displays, tap it to display collimation error and vertical index error setting menu.

Tilt Offset	HAxis Err.. Corr.	Collimation	Instr..
HA: 281°24'45"		VA: 3°06'20"	
Left value		Right value	
Description	Value	Description	Value
Left HA		Left VA	
Right HA		Right VA	
New IndexH		New Ind...	
Old IndexH	-0°00'03"	Old IndexV	81°57'12"
Enter		Cancel	
		Exit	

2. Aim at the cross-hair of collimator at telescope left, tap “Left value” to read the horizontal and vertical angles.
3. Aim at the cross-hair of collimator at telescope right, tap “Right value” to read the horizontal and vertical angles.
4. The software will calculate the new collimation error and vertical index error automatically.
5. Tap “Enter” to save the new values, or tap “Cancel” to use old values.

Note:

The adjustment can be performed by the program when $C < 30''$, if $C > 30''$, adjust the reticle.

Reticle Adjusting:

1. Rotate the instrument in face right position, turning horizontal tangent screw until $Hr' = Hr + C$.

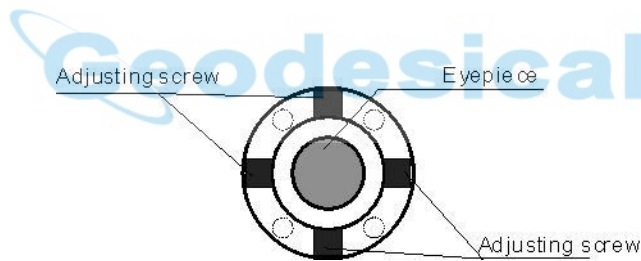

2. Loosen the shield of telescope's reticle.
3. Adjusting two screws at left and at right until the vertical hairs of telescope's reticle coincides with the cross-hairs of collimator or target.
4. Repeat the check and adjustment procedure until the error is accepted.

NOTE:

1. When adjust the screws of reticle, firstly loosen the screw on the moving direction of reticle, secondly tighten another screw by the same mount,

clockwise turning is for tightening, and anticlockwise turning is for loosening, the turning mount for tightening or loosening should be same.

2. After the reticle adjustment, it is necessary to adjust the vertical index error by program.

5.3 Vertical Index Error

The deviation between vertical circle zero position and horizontal direction is vertical index (i), it is necessary to concern this error when measure vertical angle. The instrument program applied a formula to remove this error. This correction can offer the index for the formula.

Warning: Before starting this operation, be sure to read manual carefully, otherwise it may cause data faulty.

Because of the close relationship between vertical index and compensator zero position, it is necessary to check and adjust compensator zero position when adjust the vertical circle, the value should be stable when reading.

1) Check:

Please adjust the reticle of telescope and correct the collimation error before this operation.

(1) Mount the instrument at the tripod or a stable device and level it accurately, then turn on the instrument.

(2) Aim at the cross-hairs of collimator or the obvious target at a distance, VA should be about $\pm 10^\circ$. Read the face left angle V_l and face right angle V_r .

(3) Calculate the index error according to the formula below:

$$i = (V_l + V_r - 360^\circ) / 2$$

(4) If $i < 10''$, no adjustment is necessary, or you have to adjust it.

2) Adjustment by program:

Set-up the instrument on tripod or adjustment platform, and leveling accurately.

Tilt Offset	HAxis Err.. Corr.	Collimation	Instr..	◀ ▶
HA: 281°24'45"		VA: 3°06'20"		
Left value		Right value		
Description	Value	Description	Value	
Left HA	281°24'45"	Left VA	3°06'20"	
Right HA		Right VA		
New IndexH		New Ind...		
Old IndexH	-0°00'03"	Old IndexV	81°57'12"	
Enter		Cancel		Exit

Procedures

1. Power on and enter into INST Setting. On the screen tap ◀ or ▶ keys until Collimation display, tap it to display collimation error and vertical index error setting menu.
2. Aim at the cross-hair of collimator at telescope left, tap "Left value" to read the horizontal and vertical angles.
3. Aim at the cross-hair of collimator at telescope right, tap "Right value" to read the horizontal and vertical angles.
4. The software will calculate the new collimation error and vertical index error automatically.
5. Tap "Enter" to save the new values, or tap "Cancel" to use old values.

5.4 EDM Optical Axis and the Telescope Sighting

Axis Error

It is necessary to check this error after the adjustment of telescope reticle error.

1) Checking (with prism)

(1) Install the instrument at the tripod or a stable device and level it accurately, then power on the instrument.

(2) Set a prism about 2m far away from the instrument.

(3) Aim at the prism center with telescope reticle.

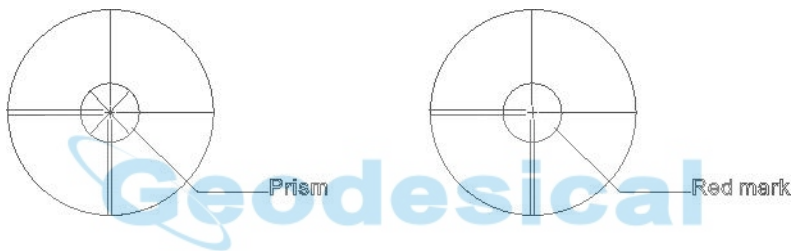

(4) Enter EDM signal testing screen.

(5) Observe through eyepiece, turn the focusing knob until the red mark is clear, if the deviation between mark and cross-hair is not over $1/5$ of red mark diameter, adjustment is unnecessary.

2) Checking (with reflective sheet)

(1) Install the instrument at the tripod or a stable device and level it accurately, then power on the instrument.

(2) Set a reflective sheet about 5m-20m far away from the instrument.

(3) Aim at the sheet cross-mark with telescope reticle.

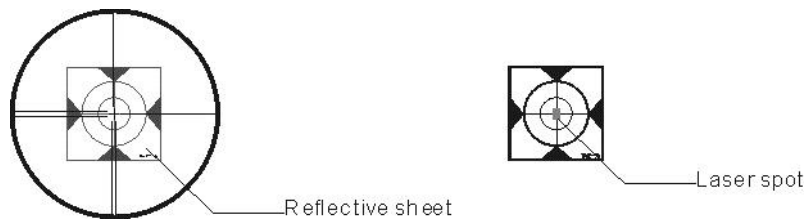

(4) Enter EDM signal testing screen.

(5) Observe the laser spot, if the laser spot coincides with the cross-mark of reflective sheet, adjustment is unnecessary.

NOTE:

Laser radiation do not stare into beam.

3) Adjustment

If the instrument needs adjustment, please contact with our dealers.

 **Geodesical**

6. Specifications

Model		LGP-302N	LGP-305N
Telescope Image		Erect	
Magnification		30x	
Effective aperture		45mm	
Resolving power		3.0"	
Field of view		1°20'	
Minimum focus distance		1.0m	
Focus		Manual	
Distance measurement	Laser class	Visible Laser : Class IIIa (Reflectorless, sheet) / Class I (Prism)	
Measurement range (Good condition) (*3)			
	Reflectorless (*1)	500m	
	Reflector sheet (*2)	800m	
	Mini Prism	1200m	
	Prism 1P	3000m	
Accuracy (*4)	Prism	$\pm(2+2\text{ppm} \times D)\text{mm}$	
	Reflector Sheet	$\pm(3+2\text{ppm} \times D)\text{mm}$	
	Reflectorless	2~150m : $\pm(3+2\text{ppm} \times D)\text{mm}$	
		150~300m: $\pm(5+2\text{ppm} \times D)\text{mm}$	
300~500m: $\pm(10+2\text{ppm} \times D)\text{mm}$			
Angle measurement	Measuring method	Absolute rotary encoder	
	Detection method	Vertical / Horizontal angle 2 sides	
	Minimum count	1" / 5"	
	Accuracy (ISO 17123-3)	2"	5"
Compensator	Axis	2 axis	
	Range	$\pm 3'$	
	Tangent screw	1 Seed/Clamping (<30")	
Sensitivity of vials	Plate level	30"/1div. (electrical)	
	Circular level	8'/2mm	
Plummet		Visible Laser, $\pm 0.5\text{mm}$ (instrument height 1.5m)	
Base		Detachable	
Dust and Water Protection		IP55 (instrument only)	

Ambient temperature		-20°C ~ 50°C / -4°F ~122°F (Working range)
Tripod thread		5/8"x 11
Dimensions / Weight	Dimensions	183 (W) x 342(H) x 167(L)mm
	Weight (battery not incl.)	5.4kg
Carrying case	Dimensions / weight	440(W) x370 (H) x275 (L)mm /3.9 kgs.
Battery pack	Power source	Li-ion 4400mAh
	Operation time	Continuous approx. 8.0hrs (ETH+EDM) with approx. 2.5hrs. of charging time
	Weight	5.4kg
Battery charger and AC Adapter		
	Input voltage	AC 100 ~ 240V
	Output voltage	DC7.4V
Data Process	CPU Memory/Clock frequency	Over 2GB/528MHZ
	OS	Microsoft Window CE 5.0
	Application software	Selectable
	I/F	RS232C, USB mini, Bluetooth(Class 2), USB Flash Drive
Display / Keyboard	Display type	3.5" colour TFT LCD (320 x 240 dots) touch screen
	Quantity	2
	Keys	26 each
Display back light		Yes
Laser Pointer		Yes
Date clock		Yes

* Specifications are subject to change without any notice

*1 The measurement range and accuracy of reflectorless, and time required to measure may vary by the shape, size of surface area and reflection rate of the target and its environment. The measurement range of reflectorless is determined by the white side of the Kodak Gray Card.

*2 Reflector sheet: Genuine Reflector sheet

*3 The measurement range may vary by conditions of the environment.

Normal conditions: 20km visibility with slight shimmer

Good conditions: 40km visibility with overcast, no heat, no shimmer and moderate wind.

*4 EDM measuring time is determined in good conditions. It may takes longer than usual to measure the distance exceeding 2000m in prism

mode and 300m in reflectorless mode.

7. Standard components

Carrying case	1 each
Instrument	1 each
Battery	2 each
Charger	1 each
AC Adapter	1 each
Power Cable	1 each
Adjusting pins	1 each
Screwdriver	1 each
Wrench	1 each
Instruction manual	1 each
USB Communication cable	1 each
Rain Cover	1 each
Plumb bob	1 each

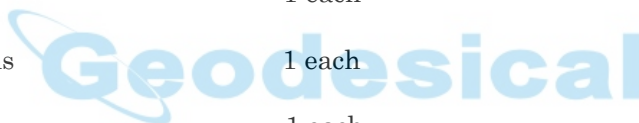
The logo for Geodesical, featuring the word "Geodesical" in a light blue, sans-serif font. A stylized blue ring or orbit surrounds the letter "G".

Appendix I: Atmospheric correction formula and chart (Just for reference)

Factory setting: temperature: 20°C, pressure: 1013hpa, 0ppm

The correction:

$$K_{pt} = 274.417 - 0.2905 \cdot p / (1 + 0.0036 \cdot t)$$

Where: p--Pressure value (hPa)

t--Temperature value (°C)

K_{pt}--Atmospheric correction (ppm)

Example:

t=20°C, p=1013hpa, L₀=1000m.

Then: K_{pt}=0ppm

$$L = L_0(1 + K_{pt}) = 1000 \times (1 + 0 \times 10^{-6}) = 1000.000\text{m}$$

The atmospheric value is obtained easily with the atmospheric correction chart. Find the measured temperature in horizontal axis, and pressure in vertical axis on the chart.

Read the value from the diagonal line, which is the required atmospheric correction value.

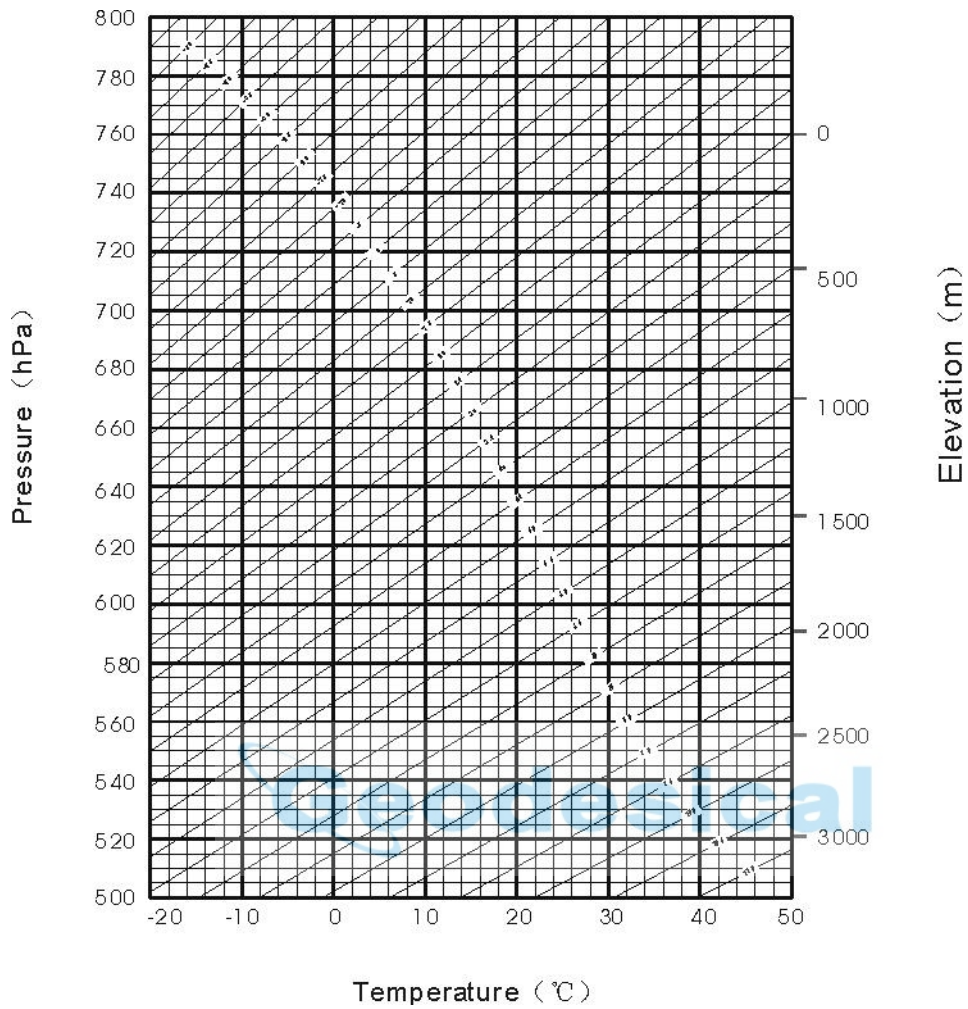

Appendix II: Correction for refraction and earth curvature

curvature

Considering the correction of refraction and earth curvature for distance measurement, the formula for slope distance, horizontal distance and vertical distance applied in the instrument are as followings:

$$SD = D_0 \times (1 + ppm \times 10^{-6}) + mm$$

- SD — Displayed slope distance (m)
- D_0 — Real measured distance (m)
- ppm — Scale coefficient (mm/km)
- mm — Target constant (mm)

$$HD = Y - A \times X \times Y$$

$$VD = X + B \times Y^2$$

- HD — Horizontal distance (mm)

- VD — Vertical distance (mm)

$$Y = SD \cdot |\sin \xi|$$

$$X = SD \cdot \cos \xi$$

- ξ — Zenith angle

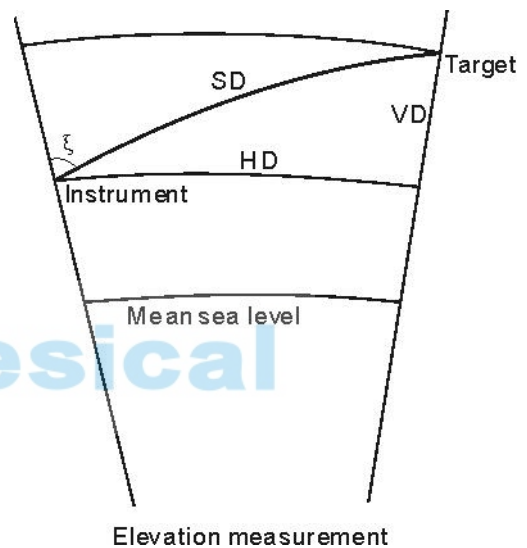

$$A = \frac{1 - \frac{K}{2}}{R}$$

$$B = \frac{1 - \frac{K}{2}}{2R}$$

$$K = 0.142 \text{ or } 0.20$$

$$R = 6.37 \times 10^6 \text{ (m)}$$

The conversion formula for horizontal and vertical distance is as follows when correction for refraction and earth curvature is not applied:

$$HD = SD \cos \xi$$

$$VD = SD |\sin \xi|$$

NOTE:

The factory setting for the refraction coefficient K is 0.142.

Refer to the section 3.10 to change the value of K.



NOTE:

These designs, figures and specifications are subject to change without notice. We shall not be held liable for damages resulting from errors in this instruction manual.

8. Labeling

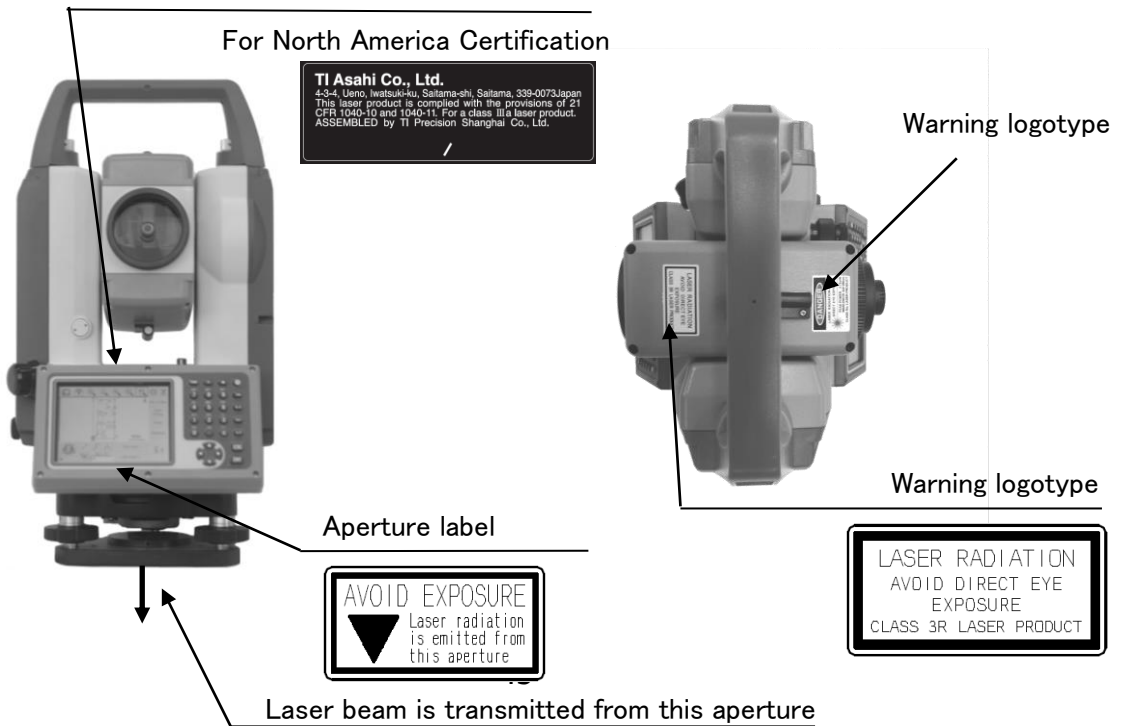
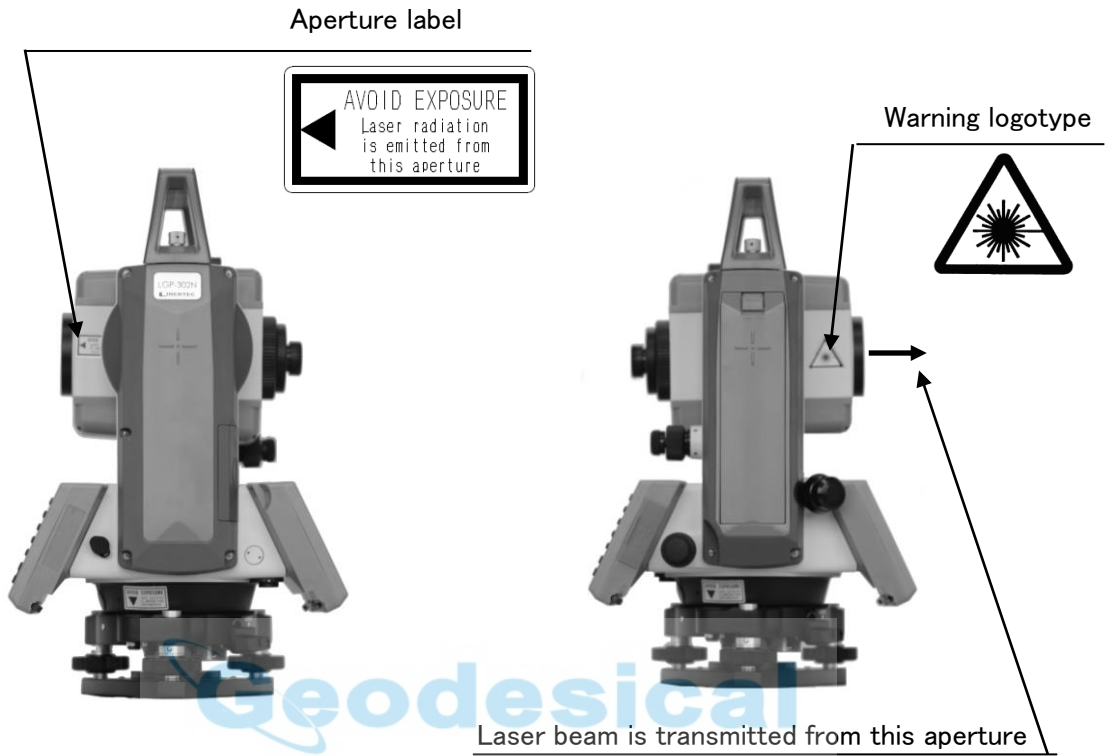

 **Geodesical**

TI Asahi Co.,Ltd.

International Sales Department

4-3-4 Ueno Iwatsuki-Ku,

Saitama-Shi

Saitama,339-0073 Japan

Tel, +81-48-793-0118

Fax, +81-48-793-0128

E-mail: international@tiasahi.com

Geodesical

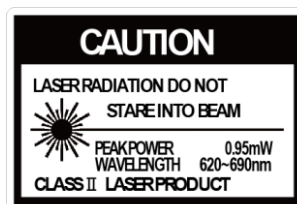

LINERTEC

LGP300150101