

# INSTRUCTION MANUAL DATA COLLECTOR FC-1000

Thank you for purchasing the TOPCON Data Collector FC-1000.

For superior product performance, please read this instruction manual carefully and keep it in a convenient place for future reference.

## GENERAL HANDLING PRECAUTIONS

- Before starting work or operation, be sure to check that the instrument is functioning correctly with normal performance.
- Always make sure instrument is dry before putting it in the soft case. Never store a damp instrument.
- Do not leave the instrument under strong sunlight for a long time. It may cause the instrument to malfunction.

## DISPLAY FOR SAFE USE

In order to ensure the safe use of this product, prevent any danger to the operator or others, or damage to property, important warnings are placed on the product and inserted in the instruction manual. We recommend that you become familiar with the meaning of these Warnings and Cautions before continuing.

## STANDARD PACKAGE COMPONENTS

Upon opening, make sure that all the followings are included.

American model	European model
1 FC-1000 Instrument..... 1set	1 FC-1000 Instrument..... 1set
2 BT-59Q Battery ..... 2pcs.	2 BT-59Q Battery ..... 2pcs.
3 Battery charger BC-29 ..... 1pc.	3 Battery charger BC-29 ..... 1pc.
4 AC-DC converter AD-9B*1) ..... 1pc.	4 AC-DC converter AD-7C*1) ..... 1pc.
5 Instruction manual ..... 1vol.	5 Instruction manual ..... 1vol.
6 Handstrap ..... 1pc.	6 Handstrap ..... 1pc.
7 Neckstrap ..... 1pc.	7 Neckstrap ..... 1pc.
8 Soft case ..... 1pc.	8 Soft case ..... 1pc.
9 Stylus pen ..... 1pc.	9 Stylus pen ..... 1pc.
10 Stylus pen holder ..... 1pc.	10 Stylus pen holder ..... 1pc.
11 Display protection sheet ..... 3pcs.	11 Display protection sheet ..... 3pcs.
12 Interface cable A-21 ..... 1pc.	12 End user license agreement ..... 1pc.
13 End user license agreement ..... 1pc.	

- \*1) AD-9B is for AC 120V use, AD-7C is for AC 230V use.  
2) Components are different by the markets.

Display	Meaning
<b>WARNING</b>	Ignoring or disregard of this display may lead to the danger of death or serious injury.
<b>CAUTION</b>	Ignoring or disregard of this display may lead to personal injury or physical damage.

- Injury refers to hurt, burn, electric shock, etc.
- Physical damage refers to extensive damage to equipment and structure or furnishings.

## SAFETY CAUTIONS

<b>WARNING</b>
<ul style="list-style-type: none"> <li>• <b>There is a risk of fire, electric shock or physical harm if you attempt to disassemble or repair the instrument yourself.</b> This is only to be carried out by TOPCON or an authorized dealer, only!</li> <li>• <b>May ignite explosively.</b> Never use an instrument near flammable gas, liquid matter, and do not use in a coal mine.</li> <li>• <b>High temperature may cause fire.</b> Do not cover the charger while it is charging.</li> <li>• <b>Risk of fire or electric shock.</b> Do not use a wet battery or charger.</li> <li>• <b>Battery can cause explosion or injury.</b> Do not dispose in fire or heat.</li> <li>• <b>To reduce the risk of hazards, use only CSA/UL certified power supply cord set, cord is Type SPT-2 or heavier, minimum No.18 AWG copper, one end is provided with a moulded-on male attachment plug cap (with a specified NEMA configuration), and the other end is provided with a moulded-on female connector body (with a specified IEC non-industrial type configuration).</b></li> </ul>

<b>WARNING</b>
<ul style="list-style-type: none"> <li>• <b>The short circuit of a battery can cause a fire.</b> Do not short circuit battery when storing it.</li> <li>• <b>Battery can cause outbreak of fire.</b> Do not use any other type of charger other than the one specified.</li> <li>• <b>Risk of fire or electric shock.</b> Do not use any power voltage except the one given on manufacturers instructions.</li> </ul>
<b>CAUTION</b>
<ul style="list-style-type: none"> <li>• <b>Do not allow skin or clothing to come into contact with acid from the batteries, if this does occur then wash off with copious amounts of water and seek</b></li> <li>• <b>Do not connect or disconnect equipment with wet hands, you are at risk of electric shocks if you do!</b></li> <li>• <b>Do not touch the charger, AC-DC converter or heating part of the instrument for a long period while charging the battery.</b> There is a risk of low-temperature burn.</li> </ul>

## Exceptions from Responsibility

- The user of this product is expected to follow all operating instructions and make periodic checks of the product's performance.
- The manufacturer, or its representatives, assumes no responsibility for results of a faulty or intentional usage or misuse including any direct, indirect, consequential damage, and loss of profits.
- The manufacturer, or its representatives, assumes no responsibility for consequential damage, and loss of profits by any disaster, (an earthquake, storms, floods etc.), fire, accident, or an act of a third party and/or a usage in other than usual conditions.
- The manufacturer, or its representatives, assumes no responsibility for any damage, and loss of profits due to a change of data, loss of data, an interruption of business etc., caused by using the product or an unusable product.
- The manufacturer, or its representatives, assumes no responsibility for any damage, and loss of profits caused by usage other than explained in the user manual.
- The manufacturer, or its representatives, assumes no responsibility for damage caused by wrong movement, or action due to connecting with other products.

## NOMENCLATURE AND FUNCTIONS

**FC-1000**

- Function key
- TAB key
- Cursor keys
- Enter key
- Power key
- Microphone
- Hook for neckstrap
- Display and Touch screen
- Escape key
- Hook for tripod
- Hook for handstrap
- Speaker
- Battery cover
- Hard reset switch (Inside the cover)
- Screw (To tighten or loosen the screw, use a coin.)
- Handstrap
- Hook for handstrap

- CF slot
- CF card
- CF slot cover
- Screw (To tighten or loosen the screw, use a coin.)
- CF card eject button (To eject the CF card, press the button.)

- Serial COM1
- USB Connector (TYPE A)
- AC adapter, external battery Connector
- Serial COM2 (Total Station)
- RUN Charge LED

### Shortcut Keys

Display Contrast	Press [Func]+[▲] or [Func]+[▼]
Front Light ON/OFF	[Func]+[.]
Ctrl Key	[Func]+[S.P]
Soft Reset	[Shift] + [Func] + [ESC]
Windows Start Menu	[Func]+[ / ]
Shortcut Commands	Press [Alt] + Tap on an item is the same as a right click on a mouse. A menu is displayed containing commands specific to the item.
Windows CE Task Manager	Press [Alt] + [TAB] to switch to another active program or to END Task on running program(s).

## CONNECTORS

### Serial COM1

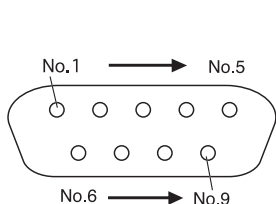

No.1	DCD	(IN)
No.2	RXD	(IN)
No.3	TXD	(OUT)
No.4	DTR	(OUT)
No.5	GND	
No.6	DSR	(IN)
No.7	RTS	(OUT)
No.8	CTS	(IN)
No.9	RI	(IN)

### Serial COM2 (Total Station)

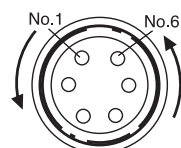

No.1	GND	
No.2	CTS	(IN)
No.3	TXD	(OUT)
No.4	RXD	(IN)
No.5	RTS	(OUT)
No.6	VDD	(IN)

### USB Connector (Type A)

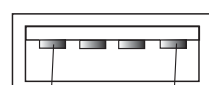

No.1	VDD
No.2	V-
No.3	V+
No.4	GND

## About Stylus Pen Holder

Stick the stylus pen holder and hold a stylus pen as shown below. When sticking the holder, wipe the attachment surface of the instrument finely.

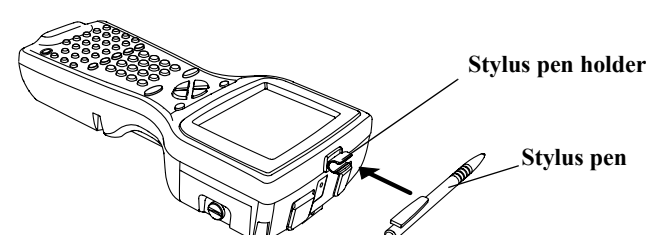

## PREPARATION FOR USE

### Battery

There are two ways to charge the battery as follows.

#### Battery Charging (Using BC-29)

Be sure to turn the FC-1000 power OFF when removing the battery, since the data will be lost.

- 1 Install the battery on the BC-29.
- 2 Plug the power cord in an outlet.(AC-120V or 230V) Charging is completed after approximately 3 hours.

The Charge LED of BC-29 will indicate charging status;

Red ON : Charging.  
Green ON : Charging completed.  
Red Flashing : Charging error.  
On Solid : Pre charging.

#### Battery Charging (Using AD-9B/7C)

- 1 After installing the battery, plug the connector of AD-9B/7C in the FC-1000.

- 2 Plug the AD-9B/7C in an outlet. Then the run charge LED will light. Charging is completed after approximately 6 hours. The display can be turned on or off by the power key.

The Run Charge LED of FC-1000 will indicate charging status;

Red ON : Charging.  
Green ON : Charging completed.  
Red Flashing : Charging error.

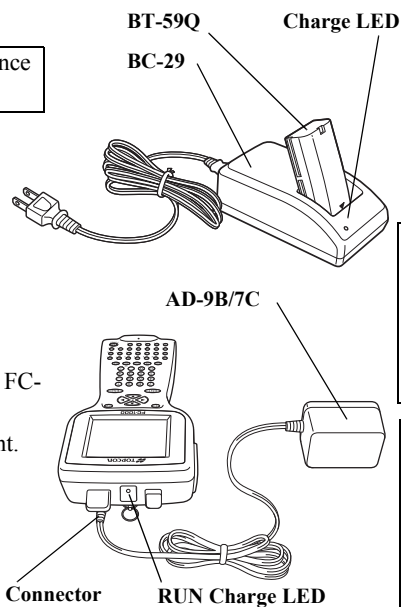

### Battery Installation

- 1 Remove the handstrap from the FC-1000.
- 2 Using a coin, loosen the screw on the battery cover.
- 3 Remove the battery cover.
- 4 Install the battery pack.
- 5 Using a coin, install the battery cover. Tighten the screw firmly.

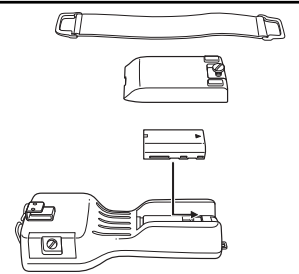

### Back-Up Battery

- The back-up battery built in FC-1000 needs to be charged approximately 24hrs. before using it for the first time after purchase. Connect the AD-9B/7C or install the fully charged BT-59Q battery to FC-1000 in order to charge the back-up battery.
- Leaving FC-1000 without the BT-59Q battery or AD-9B/7C for more than an hour will cause the memorized data to be lost, due to low voltage of the back-up battery. Connect the BT-59Q battery or AD-9B/7C as soon as possible.

### Note

- 1)Recharging should take place in a room with an ambient temperature range of +10°C to +40°C (+50°F to +104°F).
- 2)The battery source will discharge when stored and should be checked before using with instrument.
- 3)Be sure to charge a stored battery source every 15 days and store in a place at 30°C and below when it will not be used for a long period. If you allow the battery to be completely discharged, it will have an effect on the overall performance for proper charging in the future.
- 4)The charger may develop heat while charging, there is no problem of it.
- 5)If charging is done at high temperature, charging time of the battery may take longer.

**Note:** The instrument may develop heat while charging, there is no problem of it.

### Touch Screen

#### Adjusting Touch Screen

- 1 Turn on the instrument after hard-reset or tap [Start] [Setting] [Control Panel] [Stylus].
- 2 Using a stylus pen, touch the center of the cross hairs. (5 points)
- 3 After touching all corsairs, press [ENT] key.  
(Use an accessory stylus pen to touch a screen. Do not use neither a ball-point pen nor pencil.)

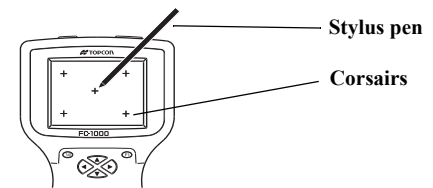

## TRANSMISSION DATA TO THE PC

### Interface Cable

- 1 Turn on the PC and the FC-1000.
- 2 Connect the FC-1000 to your PC with the interface cable A-21 as shown below.

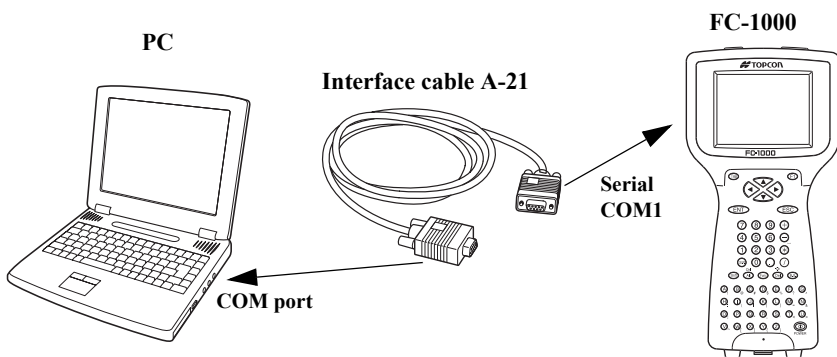

The FC-1000 will prompt "Connecting to Host".

- 3 The PC will prompt for setting up a partnership or setting up as a guest. When working as a guest, you can browse the files on your FC-1000 and copy or move information. Choose [ESC] to set up as a guest. Once a connection has been established, the icon will appear on your PC.
- 4 Click on [Explore] to move or copy files between the PC and the FC-1000.

#### Reference software for Connectivity

See the WEB page as follows.

[www.microsoft.com/mobile/pocketpc/downloads/activesync35.asp](http://www.microsoft.com/mobile/pocketpc/downloads/activesync35.asp)

### CF Card

The FC-1000 has an external CF slot, so the files in the FC-1000 can move to your PC through the CF card.

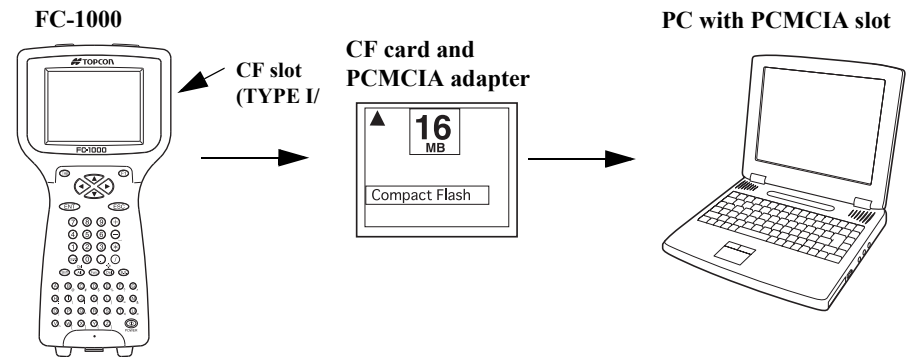

## SPECIFICATIONS

Microprocessor	: SH7750S
Processor speed	: 162MHz
MIPS	: 300MIPS
Operating system	: Microsoft® Windows® CE Ver. 3.0
Memory	: 32MB / 64MB RAM with flash ROM 2MB 32MB / 64MB / 128MB flash disk (Internal)
RAM retention	: Li-rechargeable battery(65mAh)-backed for data when main battery not present
Display	: 320x240 QVGA (monochrome) STN Reflective type Temperature compensation
Illumination	: Front light (CCFL)
Key board	: 56 key keyboard with separate alpha and numeric
Pen touch screen	: Resistive touch screen/passive Pen digitization
Interface	: RS-232C serial (6 pin) RS-232C serial (D-sub 9) USB(1.1) Compact flash : Type I / Type II (Based on Compact Flash)
External power	: 8.4V to 20V Available run charge (11V to 20V)
Audio	: Sealed Speaker (mono) Sealed Microphone
Durability	: IP66 (Based on the standard IEC 60529) *1) *1) With the connector and slot covers
Operation Temperature	: -20°C to +50°C (-4°F to +122°F)
Storage Temperature	: -30°C to +60°C (-22°F to +140°F)
Protection against shock	: Designed to protect falling on the hard surface from 1.0m above the ground.
EMC	: CE, FCC
Integral heater	: Auto/Off
Battery BT-59Q	: Li-ion rechargeable Battery 7.4V 1800mAh (This battery does not contain mercury.)
Rating	: 8 hours
Charging time	: Approx. 3.0 hours with BC-29 Approx. 6.0 hours with AD-9B/7C
Dimensions	: 255x130x61.5(mm)
Weight	: 0.8kg(with battery)

## STORAGE PRECAUTIONS

- Always clean the instrument after use.
- Use a clean cloth moistened with neutral detergent or water.
- Never use an abrasive cleaner, ether, thinner benzene, or other solvents.
- Always make sure the instrument is completely dry before storing. Dry any moisture with a soft, clean cloth.



#### EMC NOTICE

In industrial locations or in proximity to industrial power installations, this instrument might be affected by electromagnetic noise. Under such conditions, please test the instrument performance before use.

This is a CLASS A product. In a domestic environment this product may cause radio interference in which case the user may be required to take adequate measures.

#### FCC conditions

- This device complies with Part 15 of the FCC Rules. Operation is subject to the following two conditions:
- (1) This device may not cause harmful interference.
  - (2) This device must accept any interference received, including interference that may cause undesired operation.



#### TOPCON POSITIONING SYSTEMS, INC.

5758 West Las Positas Blvd., Pleasanton, CA 94588, U.S.A.  
Phone: 925-460-1300 Fax: 925-460-1315 www.topcon.com

#### TOPCON CALIFORNIA

3380 Industrial Blvd, Suite 105, West Sacramento, CA 95691, U.S.A.  
Phone: 916-374-8575 Fax: 916-374-8329

#### TOPCON MIDWEST

891 Busse Road, Elk Grove Village, IL 60007, U.S.A.  
Phone: 847-734-1700 Fax: 847-734-1712

#### TOPCON EUROPE B.V.

Essebaan 11, 2908 LJ Capelle a/d IJssel, The Netherlands.  
Phone: 010-4585077 Fax: 010-4585045 www.topconeuropa.com

#### TOPCON BELGIUM

Preenakker 8, 1785 Merchtem, Belgium  
Phone: 052-37.45.48 Fax: 052-37.45.79

#### TOPCON DEUTSCHLAND G.m.b.H.

Weidkamp 180, 45356 Essen, GERMANY  
Phone: 0201-8619-100 Fax: 0201-8619-111 ps@topcon.de www.topcon.de

#### TOPCON S.A.R.L.

89, Rue de Paris, 92585 Clichy, Cedex, France.  
Phone: 33-1-41069490 Fax: 33-1-47390251 topcon@topcon.fr

#### TOPCON ESPAÑA S.A.

HEAD OFFICE  
Frederic Mompou 5, ED. Euro 3, 08960, Sant Just Desvern Barcelona, Spain.  
Phone: 93-473-4057 Fax: 93-473-3932 www.topconesp.com

#### MADRID OFFICE

Avenida Burgos, 16E, 1 28036, Madrid, Spain.  
Phone: 91-302-4129 Fax: 91-383-3890

#### TOPCON SCANDINAVIA A. B.

Neogatan 2 S-43151 Mölndal, SWEDEN  
Phone: 031-7109200 Fax: 031-7109249

#### TOPCON (GREATBRITAIN) LTD.

HEAD OFFICE  
Topcon House Kennet Side, Bone Lane, Newbury, Berkshire RG14 5PX U.K.  
Phone: 44-1635-551120 Fax: 44-1635-551170

survey.sales@topcon.co.uk laser.sales@topcon.co.uk

#### TOPCON SOUTH ASIA PTE. LTD.

Blok 192 Pandan Loop, Pantech Industrial Complex, #07-01, Singapore 128381  
Phone: 62780222 Fax: 62733540 www.topcon.com.sg

#### TOPCON AUSTRALIA PTY. LTD.

408 Victoria Road, Gladstone, NSW 2111, Australia  
Phone: 02-9817-4666 Fax: 02-9817-4654 www.topcon.com.au

#### TOPCON INSTRUMENTS (THAILAND) CO., LTD.

77/162 Siam Sathorn Tower, 37th Fl.  
Krungthorbnuri Rd., Klongtongjai, Klongsam, Bangkok 10600 Thailand.  
Phone: 662-440-1152-7 Fax: 662-440-1158

#### TOPCON INSTRUMENTS (MALAYSIA) SDN. BHD.

Lot 226 Jalan Negara 2, Pusat Bandar Taman Melawati,  
Taman Melawati, 53100, Kuala Lumpur, Malaysia.  
Phone: 03-41079801 Fax: 03-41079796

#### TOPCON KOREA CORPORATION

2F Yooseoung Bldg., 1595-3, Seocho-Dong, Seocho-gu, Seoul, 137-876, Korea.  
Phone: 82-2-2055-0321 Fax: 82-2-2055-0319 www.topcon.co.kr

#### TOPCON OPTICAL (H.K.) LIMITED

2/F, Meeco Industrial Bldg., No. 53-55 Au Pui Wan Street, Fo Tan Road,  
Sha Tin, N.T., Hong Kong  
Phone: 2690-1328 Fax: 2690-2221 www.topcon.com.hk

#### TOPCON CORPORATION BEIJING OFFICE

Room No. 962 Poly Plaza Building, 14 Dongzhimen Nandajie,  
Dongcheng District, Beijing, 100027, China  
Phone: 10-6501-4191-2 Fax: 10-6501-4190

#### TOPCON CORPORATION BEIRUT OFFICE

P. O. BOX 70-1002 Antelias, BEIRUT-LEBANON.  
Phone: 961-4-523525/961-4-523526 Fax: 961-4-521119

#### TOPCON CORPORATION DUBAI OFFICE

P.O.Box 28595, 102, Al Naily Bldg., 245 Abu Hail Road, Deira,Dubai,UAE  
Phone: 971-4-2695211 Fax: 971-4-2695272

## TOPCON CORPORATION

75-1 Hasunuma-cho, Itabashi-ku, Tokyo 174-8580, Japan  
Phone: 3-3558-2520 Fax: 3-3960-4214 www.topcon.co.jp

FC-1000 64837 90030 0303 (4D)