

BA310

Advanced
Upright Microscope



The new BA310 from Motic is designed specifically for the rigors of daily routine work in the demanding applications of University education, Haematology and Cytology Clinical and Laboratory usage, and any other life science or medical application demanding quality optical performance. Using Motic's Color Corrected Infinity Optics (CCIS[®]) with newly designed EF-N Plan Achromats, this model's full Koehler configuration provides maximum illumination quality for even the most demanding samples. Also, the BA310's upgradeability to include additional contrast methods, discussion devices, and EPI fluorescence ensure this model will offer long term functionality to all user levels in a variety of applications.



Motic

Advanced Upright



BA310 Binocular



BA310 Trinocular

BA310 Microscope

The New BA310 Series

The demands placed on any routine microscope for daily work needs careful focus on every microscope detail. In this new design, MOTIC has paid careful attention to optimize the new BA310 features in all respects. The 30W illumination provides the user with a powerful and adjustable light source to meet both delicate and detailed lighting requirements for all sample types while the fully featured Koehler illumination of the BA310 helps in highlighting even the weakest stained specimens.

Motic's new CCIS[®] Infinity Optics, the EF-N Plan Achromat objectives, provide optimal image contrast through newly designed multi-layer lens coatings. The new fully corrected tube lens and subsequent intermediate image without color fringing is now fully accessible through both eyepiece and trinocular port making digital images as crisp and clear as those seen through the eyepieces. The new BA310 design also includes a standardized (DIN/ISO) photoport exit.

The BA310's large, hard coated and chemical resistant stage, with an expansive 76x50mm travel range, includes a new slide holder with improved tighter grip. This ensures easy and repeatable scanning of numerous slides in all daily routines.



► CCIS® Objectives

To improve overall optical performance of the BA310, Motic introduces a newly designed generation of Plan Achromatic Objectives made of high quality optical glass: CCIS® EF-N Plan. These new lenses are now MULTI LAYER COATED for improved contrast to enhance images even with weak slide stainings.

Together with a newly calculated tube lens, the result is a FULLY CORRECTED, perfected intermediate image without colored fringes. The Trinocular BA310 gives digital access to the same for even sharper imaging and improved digital output quality for professional results at the student level.

Type	N.A.	W.D. (mm)
EF-N Plan 4X	0.1	6.3
EF-N Plan 10X	0.25	4.4
EF-N Plan 20X	0.4	4.66
EF-N Plan 40X, Spring	0.65	0.35
EF-N Plan 60X, Spring	0.85	0.13
EF-N Plan 100X, Spring, Oil	1.25	0.13
EF-N Plan Phase 10X	0.25	4.4
EF-N Plan Phase 40X, Spring	0.65	0.35

► Eyepieces

The new standard eyepieces also made of high quality optical glass, N-WF 10x/18 FOV or N-WF 10x/20 FOV with high-eyepoint for eyeglass wearers provides consistent diopter adjustments for both eyes. This enables perfect usage of reticles for measuring, counting, etc. Standard lockable eyepieces ensure against inadmissible removal and confirms Motic's dedication to student proof quality.

The following reticles are available:

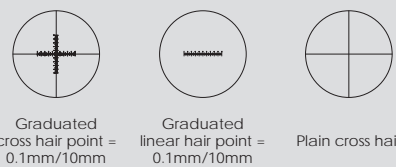

Description	F.N.
Widefield high eye point N-WF 10X	20
Widefield high eye point N-WF 12.5X	16
Widefield high eye point N-WF 15X	13.3

► Observation Tubes

Designed with an ergonomic viewing angle of 30° and incorporating an interpupillary distance of 55-75mm, the BA310 observation tubes guarantee fatigue-free viewing for hours.

A large field of view option (20mm) enables fast and comfortable screening.

The trinocular tubes allow digital documentation and integration of each BA310 into a wide variety of digital cameras, with optional 20/80 or 0/100 light splits for the trinocular exit.



► Illumination

The BA310 introduces a new collector lens assembly with a secure, screw-on holder for the frequently used Blue daylight filter which is an integral part of the illumination package. The fixed cap prevents the filter from dropping when the instrument is stored.

6V/30W Halogen or 3W LED, the BA310 offers multiple illumination options to use on the microscope.

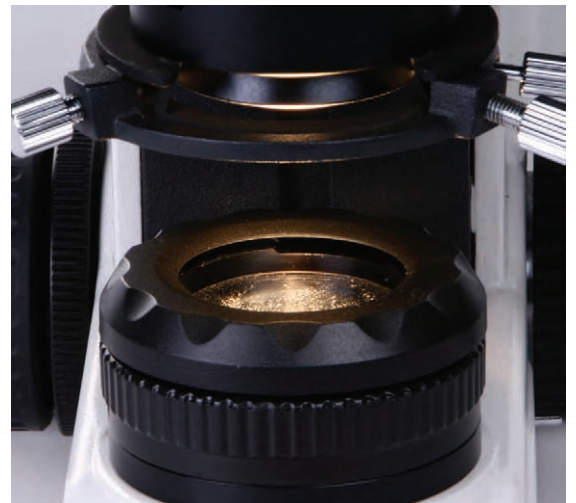

► Condenser

To ensure the best possible illumination quality, BA310 has a full Koehler feature giving complete freedom to set the height of the condenser. So even counting chambers with unusual height dimensions can be used.

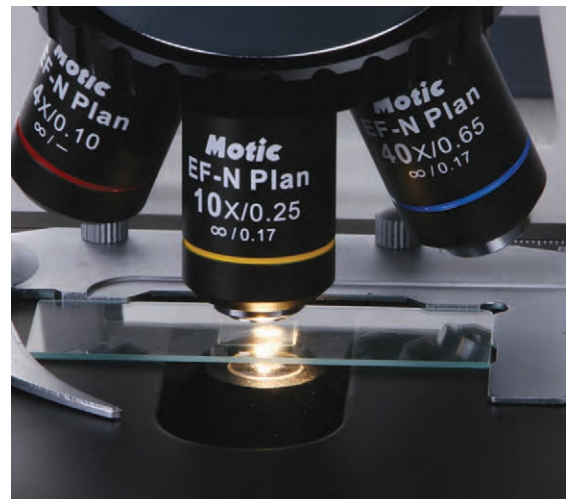



► Mechanical Stage

The BA310 surprisingly offers an optional left/right hand control and the new slide holder enables consistent sample movement across a 76 X 50mm range with a stage area of 175mm X 140mm. The model also offers a hard coated surface, resistant against routine usage abrasion and most lab chemicals.



► Multi Viewing Devices

Due to modern camera chip dimensions, digital cameras are only able to display a part of the image provided by the microscope. To overcome this situation, Motic offers multi-viewing devices for teaching especially in Pathology and Histology.

For BA310 model, 2 options are available. Depending on the teaching situation in your laboratory, MVH-2 can be realized as a face-to-face or a side-by-side solution. With a field of 20mm provided by Motic's BA310 maximum information will be given to the student. Pointers provided in red and green colour.

For more student stations please refer to our BIOLOGICAL CATALOGUE.

► Anti-Fungus Design

To protect the system from fungus formation in high-humidity environments, an anti-fungus device is used to prolong the life of both microscope and objectives.



► Phase Contrast and Darkfield

Simple Phase Contrast

Offered as an option, phase contrast is available for magnifications 10X and 40X.

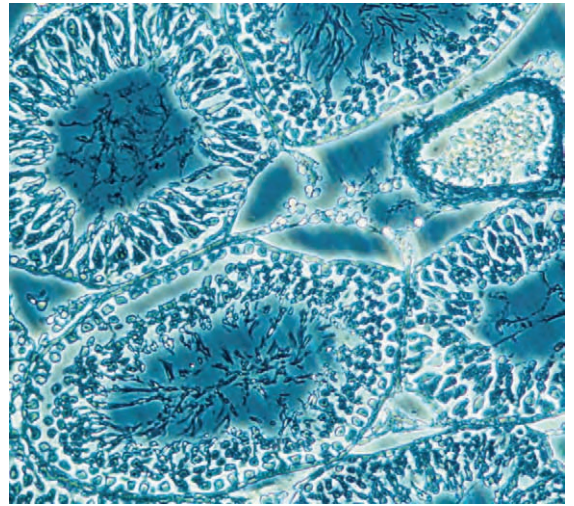

Simple Darkfield

Darkfield is possible with a separate DF slider.

Phase Contrast

Also available is the 5-position turret type phase contrast condenser and the CCIS® phase plan objectives.

2 options for 5-position turret condenser	CCIS Plan Phase objectives	W.D.
BF, 10X, 20X, 40X, 100X	PL Ph 10X	4.3mm
BF, DF, 10X, 40X, 100X	PL Ph 20X	1.3mm
	PL Ph 40X	0.4mm
	PL Ph 100X	0.13mm

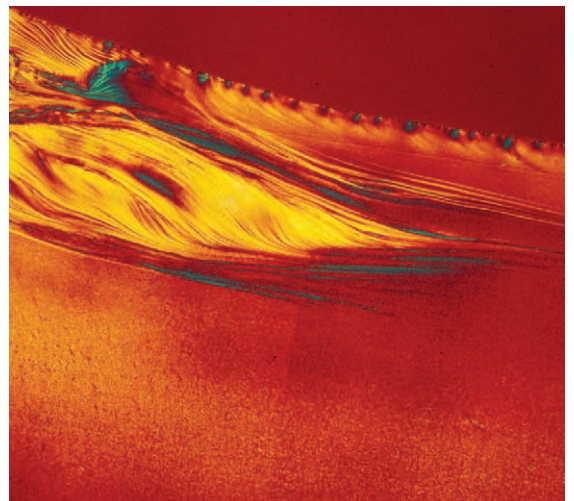

► Simple Polarisation

Convenient and simple, the BA310 polarisation system consists of an analyser filter placed between the head and body; and a polariser filter placed on top of the collector lens.

Documentation

The importance of documentation has expanded into every aspect of microscopy, as has the method of documentation. The BA310 is available with both a traditional method (photomicrography) and a digital method.

► Standard Photomicrography

Selecting the trinocular version of the BA310 allows the user to capture the images observed through a photomicrography system.

The system consists of a mechanical adaptation combined with a photo eyepiece (2.5X or 4X)

The T2 adapter referring to the camera model is supplied by the camera manufacturer.

► Digital Documentation

Digitalisation of microscopy is Motic's philosophy and the BA310 provides two methods of digitalisation.

The integration of the BA310 trinocular microscope and Moticam series of digital cameras delivers crisp and live images. All Moticams come equipped with software to transfer the BA310 into an analysis and documentation station. Please consult the Motic Digital Series of brochures for further details. Should you select a third-party camera, Motic provides a range of CCD-adapters covering all demands for field vs. resolution.

Another digitalisation option is the BA310 digital head. Conventional replacement of the existing head with BA310 Digital transforms the BA310 into a teaching, training, and analysis station without the hassle of adapters and focus corrections. With a USB2.0 output to the computer, the system provides high resolution imaging in both real time and capture modes. For further information, please refer to the BA310 Digital brochures.



■ BA310 Trinocular



■ Moticam 2300



■ Moticam 2500

► BA310 Digital Schematic Diagrams

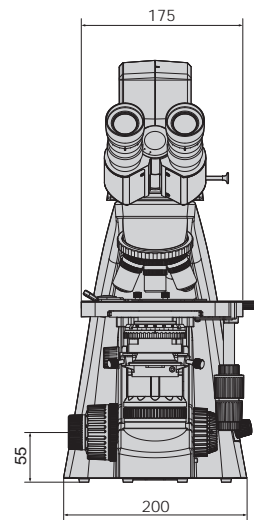
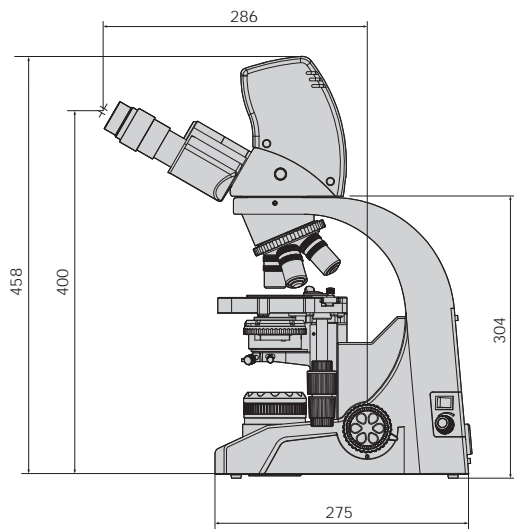

Unit: mm

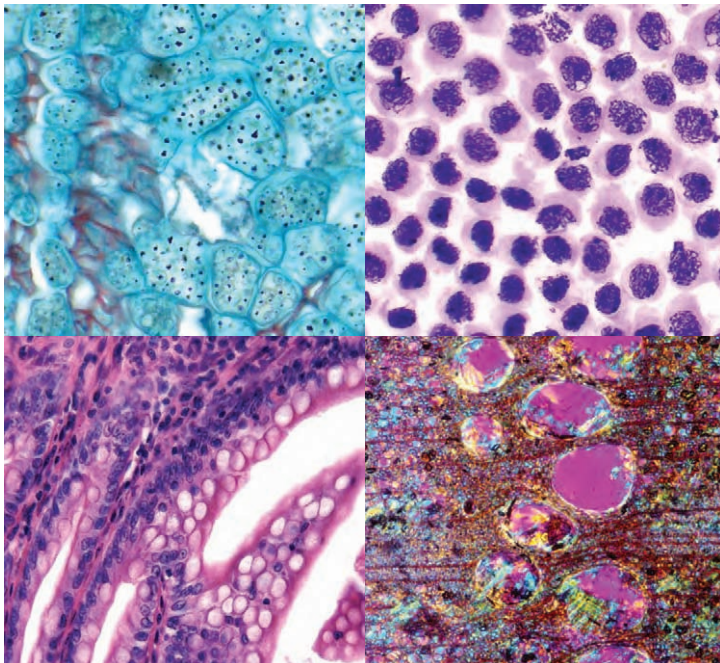

■ BA310 Digital

► BA310 Standard Specifications

Model	BA310
Optical System	Color Corrected Infinity Optical System [CCIS®]
Observation Tube	Widefield binocular 30° [F.N. 20] Widefield trinocular 30° [F.N. 20]- light distribution 20/80 Widefield trinocular 30° [F.N. 20]- light distribution 0/100
Nosepiece	Reversed quintuple
Stage	175 x 140mm surface; 76 x 50mm movement; coaxial movement
Condenser	N.A. 0.9 / 1.25 Abbe condenser with slider slot; Focusable and Centerable
Focus	Brass gears 25mm stroke; 2µm minimum increments; torque adjustment for coarse; stage lock
Illumination	Built-in transmitted 6V/30W halogen critical illumination Built-in transmitted 3W LED illumination; 5,500K Colour Temperature; >10,000 hrs bulb life span

► BA310 Digital Standard Specifications

Model	BA310 Digital	
Optical System	Color Corrected Infinity Optical System [CCIS®]	
Observation Tube	Widefield binocular 30° [F.N. 20] with built-in 3 megapixel digital camera- light distribution 20/80	
Camera Specifications	Effective Pixels	3 megapixels
	Live Image Resolution	2048 x 1536
	Data Transfer	480 MB/Second, USB2.0
	White Balance	Manual adjusted using software
	Recommended System Requirements	Windows: XP or Vista; P4 1.0GHz 256MB RAM, USB2.0 Mac: OSX, 1.0GHz 256MB RAM, USB2.0

► BA310 Schematic Diagrams

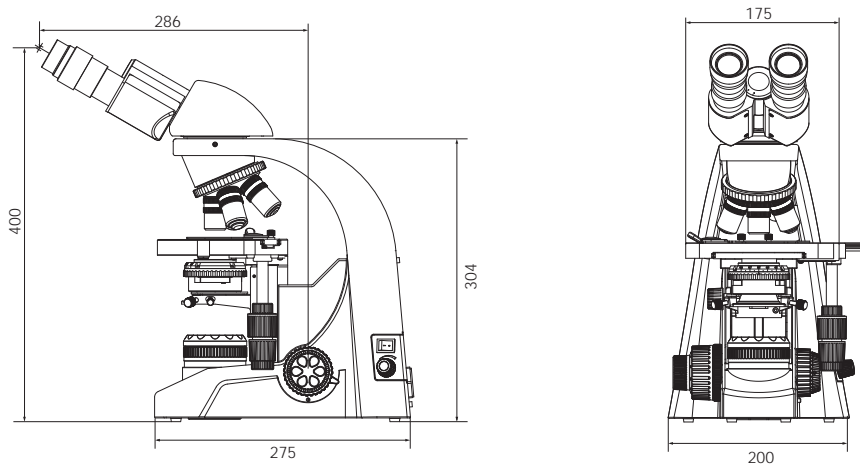

Unit: mm

▶ BA310 System Diagram

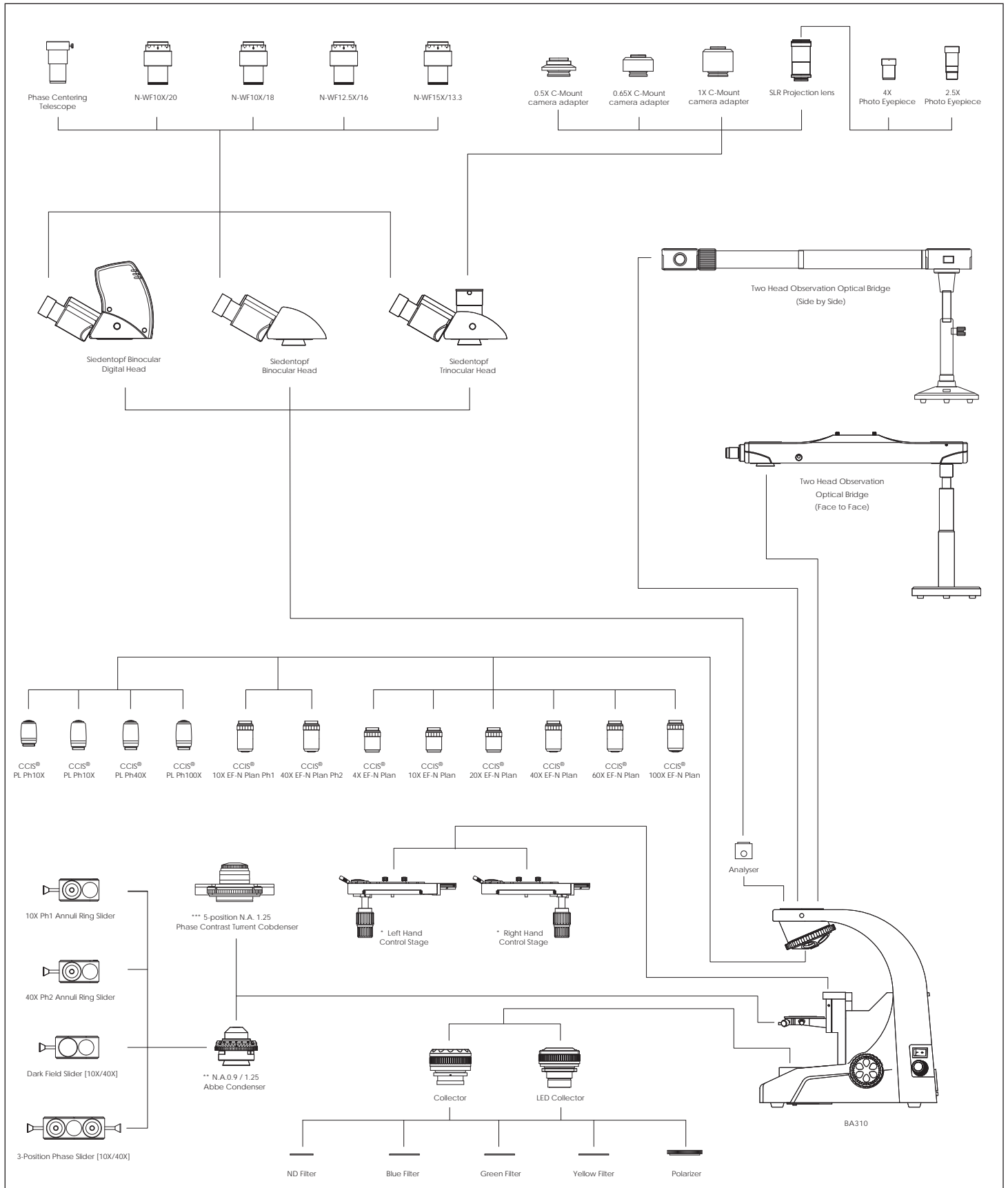

* Stages: To be ordered with stand

** EF-N Plan Phase objectives are to be used with phase sliders

*** Plan Phase objectives are to be used with turret phase condensers